

# **INDUSTRIAL ARTS: ELECTRICITY (PREPARING ELECTRIC AND HYDRAULIC TOOLS)**

Learner's Material

This instructional material was collaboratively developed and reviewed by educators from public and private schools, colleges, and/or universities. We encourage teachers and other education stakeholders to email their feedback, comments, and recommendations to the Department of Education at [action@deped.gov.ph](mailto:action@deped.gov.ph).

**We value your feedback and recommendations.**

**Department of Education  
Republic of the Philippines**

**Technology & Livelihood Education – Grade 9**  
**Industrial Arts: Electricity - (Preparing Electric and Hydraulic Tools)**  
**Learner’s Material**  
**First Edition, 2014**

**Republic Act 8293, section 176** states that: No copyright shall subsist in any work of the Government of the Philippines. However, prior approval of the government agency or office wherein the work is created shall be necessary for exploitation of such work for profit. Such agency or office may, among other things, impose as a condition the payment of royalties.

Borrowed materials (i.e., songs, stories, poems, pictures, photos, brand names, trademarks, etc.) included in this book are owned by their respective copyright holders. Every effort has been exerted to locate and seek permission to use these materials from their respective copyright owners. The publisher and authors do not represent nor claim ownership over them.

Published by the Department of Education

Secretary: Br. Armin A. Luistro FSC

Undersecretary: Dina S. Ocampo, Ph.D.

**Development Team of the Learner’s Material**

**Consultant:** Rosendo R. Rafael, Howard Mark N. Plete  
and Clodualdo V. Paiton

**Authors:**  
ROBERTO S. DAQUIL and FERNANDO N. MAGALANG

**Editor:** Lando T. Guzman

**Reviewers:** Dr. Orlando E. Manuel, Dr. Fely L. Manuel,  
Dr. Romeo R. Vicmudo, Merham N. Abelardo, Arnel C. Anonical,  
Joel G. Castillo, Marvin A. Mendoza, Lino A. Olit

**Illustrator:**

**Subject Specialists:** Albert Erni, James Julius M. Liquigan,  
Owen S. Milambiling

**Management Team:** Lolita M. Andrada, Jocelyn DR Andaya,  
Bella O. Mariñas and Jose D. Tuguinayo Jr.

**Department of Education-Instructional Materials Council Secretariat  
(DepEd-IMCS)**

Office Address: 5<sup>th</sup> Floor Mabini Building, DepEd Complex  
Meralco Avenue, Pasig City  
Philippines 1600

Telefax: (02) 634-1054 or 634-1072

E-mail Address: imcsetd@yahoo.com

# Table of Contents

## PREPARING ELECTRIC AND HYDRAULIC TOOLS

Introduction .....	1
Pre/Diagnostic 1.....	1
Information Sheet 1.1 .....	2
Information Sheet 1.2 .....	10
Activity Sheet 1.1 .....	11
Activity Sheet 1.2 .....	12
Information Sheet 1.3.....	13
Activity Sheet 1.3 .....	20
Activity Sheet 1.4 .....	20
Self-Check 1.1 .....	21
Self-Check 1.2.....	22
Self-Check 1.3.....	22
Self-Check 1.4.....	23
Self-Check 1.5.....	23
Self-Check 1.6.....	24
Information Sheet 2.1.....	26
Activity Sheet 2.1 .....	28
Information Sheet 2.2.....	29
Information Sheet 2.3.....	31
Activity Sheet 2.2.....	33
Activity Sheet 2.3.....	33
Information Sheet 2.4.....	34
Activity Sheet 2.4.....	36
Information Sheet 2.5.....	37
Self-Check 2.1.....	45
Self-Check 2.2.....	46
Self-Check 2.3.....	46
Self-Check 2.4.....	47
<b>Summative Assessment</b> .....	<b>48</b>



# PREPARING ELECTRIC AND HYDRAULIC TOOLS

Content Standard	Performance Standard
The learner demonstrates understanding of principles in the preparation of electric and hydraulic tools.	The learner independently prepares electric and hydraulic tools for the given task.

## I. INTRODUCTION:

This module contains information and suggested learning activities on the preparation of electric materials and tools. It includes instructions and procedure on how to prepare appropriate tools and materials needed in electrical wiring installation; in storing unused and surplus electrical materials upon completion of the job; and maintaining and storing basic tools and equipment.

This module consists of two (2) learning outcomes. Each learning outcome contains learning activities with instruction sheets. Before you start, read well the information sheets; answer the self-check; and do the activities provided by your teacher to assess your competence. He/she will check if you have acquired the knowledge necessary to perform the skill portion of the particular learning outcome.

### Select electric and hydraulic tools

- Request tools, equipment, and materials
- Identify electric and hydraulic tools for the task
- Inspect tools and equipment for damage prior to their use
- Report damaged tools

### Pre/Diagnostic Assessment





**A. Direction:** Select the best answer. Write the letter of the correct answer in your answer sheet.

1. It is a machine used to bore holes on thin metals.  
a. portable electric drill    b. portable grinder    c. hammer drill
2. It is a \_\_\_\_ that uses pressurized fluid oil to accomplish the work.  
a. pneumatic    b. hydraulic    c. Electric
3. it is a tool used to bend rigid metallic conduits more than 1” in diameter.  
a. hydraulic pump  
b. hydraulic pipe bender  
c. hydraulic knockout

4. It is a picture symbol intended you to alert you to, and/or instruct you on how to avoid, a potentially hazardous condition.
- a. symbol                                      b. sign                                      c. warning icon

5. What is the preferred size of extension cord for portable grinder?
- a. # 5.5mm<sup>2</sup>                                      b. # 3.5mm<sup>2</sup>                                      c. # 2.0mm<sup>2</sup>

**B. Direction:** Match Column A with Column B. Write the letter of the correct answer in your answer sheet.

Column A	Column B
1. Read and understand Instructional manual	a. 
2. Danger	b. 
3. Prohibition	c. 
4. Safety alert	d. 
5. Wear eye protection	e. 

**INFORMATION SHEET 1.1**  
**ELECTRICAL TOOLS AND MATERIALS**

**Pliers.** They could be with insulated or uninsulated handles. The handle insulation is not considered sufficient protection alone. Other safety precaution must be observed. The common types of pliers are:



Slip joint



Diagonal cutting



Side cutting



Retainer ring



Long nose



Snap ring

**Screw drivers** are used to drive and pull out screws. They come in various sizes and shapes and with either sharp or square tips. The width of the screw driver should match the width of the screw slot. Common types of screw drivers are:



Standard type



Phillips



Offset



**Wire puller (fish wire)** is used to pull wires into the conduit or raceway.

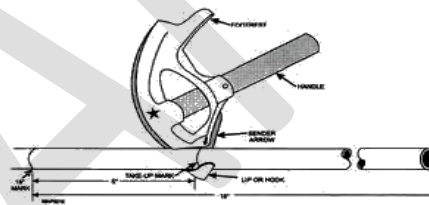

**EMT bender** is a tool used to bend electrical metal tubing.

**Drilling Equipment** is needed to make holes in building structure for passage of wires and conduit in both new and old installation, indoor or outdoor wiring. Common types of drilling tools and equipment are:



Electric drill



Auger brace



Hand drill



Gimlet



Drill bits



Masonry bit



**Soldering tools** are used in making splices and taps connections of wires.



**Soldering gun**



**Blow torch**

**Hammers** are used to drive and pull out nails. They are made of either hard steel or plastic. A claw hammer with fiberglass insulated handle is specially designed for electricians. Common examples of hammer are:



Claw hammer



Ball peen hammer



Mallet (Plastic or rubber hammer)



**Measuring tools and instrument.** The electrician uses the following measuring tools and devices to measure value of voltage, current and resistance, wire length, opening sizes of wire, conduit and other items.



Steel Tape(push/pull roll)



Wire gauge



Vernier caliper





Multitester



Voltmeter



Ammeter



Galvanometer



Micrometer caliper



Clamp meter



Megger



Phase Sequence Tester



High Potential Tester



**Sawing and cutting tool.** Two of the commonly used types of saw are:



Hack saw



Keyhole saw

## Electrical Materials

### A. Wires and Cables

- **A Wire** is a single, usually cylindrical, flexible strand or rod of metal.

### Stranded wire

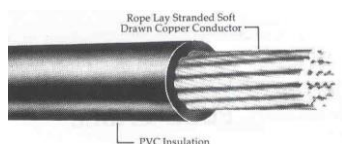

**AWG no. 8**



**Solid Wire**

- **Cables** are composed of two or more electric conductors insulated from one another. They are larger than wires



**Cable**

### Types of Wire and Cable Insulation

Insulations	Letter Type
Weather Proof	WP
Slow Burning	SB
Slow Burning Weather proof	SBW
Rubber – Code Compound	R
Heat Resistant	RH
Moisture Resistant	RW
Moisture and Heat Resistant	RH – RW
Latex (Regular)	RU
Latex (Moisture Resistant)	RU
Mineral (Metal – Sheated)	MI
<b>Thermoplastic Compound</b>	
Thermoplastic	T
Moisture – Resistant Thermoplastic	TW
Moisture and Heat Resistant Thermoplastic	THW
Thermoplastic and Fibrous Outer Braid	TBS
Thermoplastic and Asbestos	T
Varnish Cambric	
Standard Black	
Heat Resisting	V
Paper	
Solid Type	
Oil – Filled	
Untreated	
Treated	

<b>Asbestos</b>	
Non – impregnated	A and AA
Impregnated	AI and AIA
Asbestos – Varnished – Cambric	
Outer Asbestos Braid	AVA
Lead Covered	
Cotton Braid Covered	AVB
Silicon Asbestos	SA

## B. Electrical Boxes

Electrical boxes are made of steel and nonmetallic materials(plastic). Metal boxes are made of #14 heavy galvanized steel and available in four principal shapes: square, octagon, rectangular, and circular.



Utility box



Octagonal box



Square box



Circuit breaker box



Panel box



Safety switch box

## C. Fuses and circuit breakers

Fuses and circuit breakers are electrical protective devices which are used to interrupt the flow of current when short circuit or over current occurs. They are available in different sizes and shapes and ratings. The common types are:



Cartridge fuse



Knife blade fuse



Plug fuse



Molded-case  
Circuit breaker (3-  
pole type shown)

### D. Switch

It is an electrical device which is used to turn **ON** and **OFF** the circuit.



Flush type



Tumbler type

### E. Fittings and accessories

These are some electrical materials which are commonly used to fit wiring devices during wiring installation. The following are some examples of these materials:



Insulated staple nail



Condulets



Porcelain tubing



Electrical tape



Sand paper



PVC fittings



Metal clamp



Double clamp



Male plugs



Connectors



Coupling



Liquid Tight Connector



Locknut and Bushing

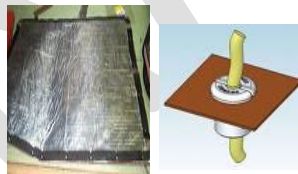

Wire Bushing



Wire Connector

Anchor and fastening devices are as follows:

- a. Screw
- b. Bolts
- c. Screw anchor (tox)
- d. Expansion bolt
- e. Spring wing toggle bolt

**INFORMATION SHEET 1.2**  
**REQUISITION SLIP FORM**

**Requisition slip form** is a written or printed request of something that is needed.

**REQUISITION SLIP FORM (SAMPLE)**

Name: **Juan dela Cruz**

Date:

Project: **Extension wire**

Location: **School Campus**

Classification: **Electrical Installation and Maintenance NC II**

Purpose: **For Electrical laboratory use**

NO.	QUANTIY	UNIT	DESCRIPTION	UNIT COST	TOTAL COST
1	10	mtrs	Flat cord wire #14 AWG		
2	1	pc	3 Gang outlet (surface type)		
3	1	pc	Male plug ( heavy duty)		

\_\_\_\_\_  
Requisitioner

\_\_\_\_\_  
Teacher

**INVENTORY FORM (SAMPLE)**

**Inventory form** is a list of tools, materials, property and other resources.

Name: Juan dela Cruz

Section: \_\_\_\_\_

School: \_\_\_\_\_

Shop lab: Electricity

Purpose: \_\_\_\_\_

Tools / Equipment	Quantity	No. of Functional	No. of Not Functional But Repairable	No. of Condemnable	No. of Borrowed	No. of Missing
pliers	13	12		1	0	0
power drill	5	4	1		0	0
hacksaw	11	10		1	0	0

\_\_\_\_\_  
Requisitioner

\_\_\_\_\_  
Teacher

**ACTIVITY SHEET 1.1**  
**PREPARING REQUISITION SLIP FORM**

**Direction:** Using the given format below, make a requisition for your electrical project which is wiring up a small room with a lamp controlled by a switch. The activity will involve embedding a rigid conduit on the concrete wall and wooden ceiling.

**Requisition Slip Form**

**Name:** \_\_\_\_\_

**Project:** \_\_\_\_\_

**Location:** \_\_\_\_\_

**Classification:** \_\_\_\_\_

**Purpose:** \_\_\_\_\_

No.	Quantity	Unit	Description	Unit Cost	Total Cost

\_\_\_\_\_  
Requisitioner

\_\_\_\_\_  
Teacher

**ACTIVITY SHEET 1.2**  
**PREPARING AN INVENTORY FORM**

Direction: Using the given format below, make an inventory of your shop laboratory tools.

**Inventory Form of Tools**

Name: \_\_\_\_\_

Project: \_\_\_\_\_

Location: \_\_\_\_\_

Classification: \_\_\_\_\_

Purpose: \_\_\_\_\_

Tools Equipment	Quantity	No. of Functional Items	No. of Not Functional but Repairable Items	No. of Condemnable Items	No. of Borrowed Items	No. of Missing Items

\_\_\_\_\_  
Inventory by:

\_\_\_\_\_  
Teacher



## **INFORMATION SHEET 1.3**

### **IDENTIFYING ELECTRICAL POWER TOOLS**

#### **COMMON ELECTRICAL POWER TOOLS**

Electrical tools are used to multiply manual work of humans. Tools can be considered as extension of the human hand thereby increasing its speed, power and accuracy.

#### **Advantages of using proper electrical tools**

1. Efficiency of the work is met.
2. High quality of work is achieved.
3. Accomplishment of a task is faster.
4. Accuracy is obtained.
5. It is less stressful on the part of the user.

However, these advantages depend upon the three factors, namely:

- availability and sufficiency of materials,
- experience and skill of the workers in using the tools, and
- quality of tools and equipment

Different kinds of construction tools may be classified according to the different kinds of trade namely:

- carpentry tools
- masonry tools
- tinsmith tools
- painters tools
- plumbing tools
- electrical tools

#### **General safety rules for using power equipment**

- Always follow manufacturer's operating instructions.
- Never place hands in a pinch point.
- Use eye protection.
- Wear gloves when working with hot equipment or materials.
- Always secure loose clothing such as shirt sleeves and shirttails.
- Tie back long hair and do not wear dangling jewelry.
- Never exceed rated capacity of the equipment.
- Never remove protective guards from the equipment.
- Be prepared for an unexpected event.

**Portable Electric Drill** is a small drilling machine with a chuck of  $\frac{1}{4}$ " and  $\frac{3}{8}$ ". It is used to bore holes on lighter metal work.

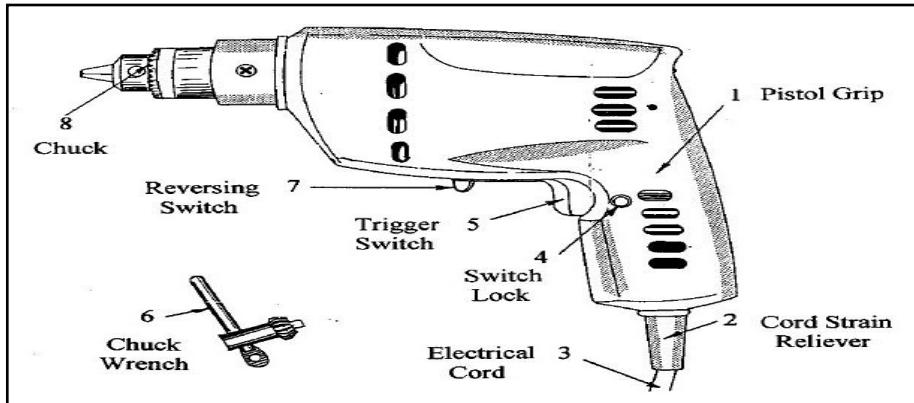

Figure 1. Parts of a Portable Electric Drill

### **Safety Precautions in Using Portable Electric Drill**

1. Wear safety glasses when operating the portable electric drill.
2. Disconnect the drill from the electrical supply when installing the bits.
3. Clamp stock so it will not move during the drilling operation.
4. Before drilling, turn the drill on to see if the bit is centered and at place.
5. Align the bit with the desired hole location before turning on the drill.
6. Hold the drill firmly with both hands while drilling.
7. When drilling deep holes with a twist drill, move the bit up and down several times while drilling to remove cuttings and reduce overheating in the bit.
8. Avoid the cord to wrap around the drill when working.
9. If the electrical cord becomes frayed or begins to separate from the drill housing, repair it immediately.
10. Remove the bit from the drill as soon as the work is completed.
11. Select the correct bit for the finish and material being drilled. Make sure that the bit is securely tightened in the drill chuck.
12. Be extremely careful when using larger portable electric drills ( $\frac{3}{8}$ " and  $\frac{1}{2}$ "). If the bit hangs or gets caught the drill will twist in the operator's hands causing a sprain or bruise.
13. Always remove the key from the chuck before drilling.
14. To prevent seizing, reduce the feed pressure when the drill bit is about to come through the material.

### **Procedure in using Portable Electric Drill**

1. Always put the punch at the center or make a starting indentation in the material being drilled to get an accurate starting point for the drill bit.
2. Tighten the drill bit by rotating the chuck key to all three holes in the chuck. This will help you to keep the drill bit centered.

3. Use only straight shank or silver and deming drill bits in portable electric drills.
4. Apply moderate pressure to the drill during the drilling operation. If excessive pressure is required to make the bit cut, it means that the bit needs to be sharpened.
5. Maintain good balance at all times when drilling.
6. Use slow drill speed for drilling metal and fast speeds for drilling wood.
7. To obtain holes that are placed accurately, drill a small pilot first. Then, drill the final hole.

**Portable Grinder** is a hand-held rotating machine used for grinding and cutting processes depending on the type of disc fitted to the machine. For cutting concrete , a “diamond” cutting disc is used.

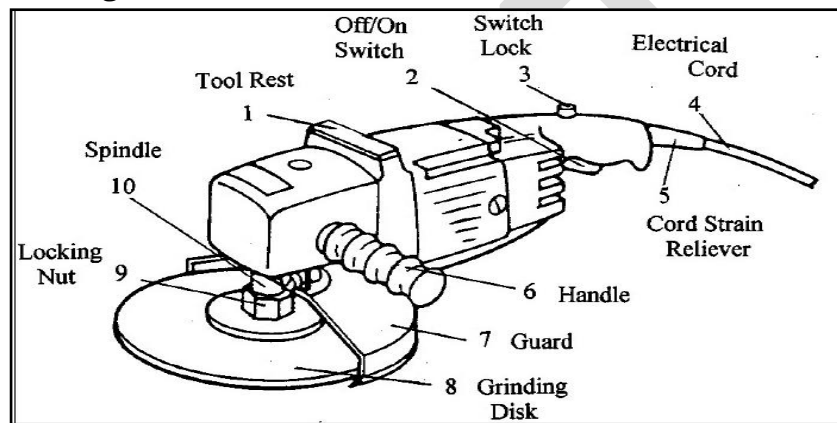

Figure 2. Parts of a Portable Grinder

### Safety Precautions in Using the Portable Disc Grinder

1. Wear safety glasses, or face shield at all times when using the portable disc grinder.
2. Wear hearing protection when grinding operating the portable disc grinder.
3. Position the grinder so that sparks and grits thrown during grinding will not hit you or the other people working in the area.
4. Make sure the material being ground is well secured.
5. Never grind with the portable disc grinder in an area with flammable materials or combustible gases.
6. Replace the grinding disk when half its original diameter wears out.
7. Wear long sleeve leather gloves when grinding to protect hands and forearms from injury.
8. Hold the portable disk grinder with both hands when grinding.
9. Never lay the portable disc grinder down until the disk stopped rotating.
10. Keep the electrical cords and extension cords out of the way work when grinding.

11. When using the wire brush attachment on the portable disc grinder, hold the grinder firmly to prevent it from being thrown away and from causing an accident.
12. Caution others in the work area to wear safety glasses, hearing protection and to watch out for any thrown sparks and grits.

### **Procedure in using Portable Disc Grinder**

1. Tighten the grinding disk snugly when mounting it on the portable disc grinder. The disk will tighten itself during normal operation.
2. Be sure to hold the portable disc grinder firmly when the switch is turned on. The centrifugal force created by the rotating disk will cause the portable disc grinder to move or jump.
3. For extended periods of grinding, the operator may lock the switch on position to avoid fatigue from holding the switch on manually.
4. When an extension cord is used with the portable disc grinder, make sure that the cord is sufficiently large in size for the grinder. A #14 (2.0mm<sup>2</sup>) gauge extension cord is minimum and #12 (3.5mm<sup>2</sup>) gauge is preferred.
5. Keep the electrical and extension cords away from the grinding area. Cords can be damaged by the portable disc grinder.
6. When laying the portable disc grinder down, always position it on the tool rest.
7. Before using the switch lock on the portable disc grinder, always check to make sure the lock is functioning properly.
8. Hold the portable disc grinder so that sparks and grit are thrown away from the from others who are working in the area.
9. Operating the portable disc grinder is a hard work and causes fatigue. Take rest and don't be exhausted.

### **Safety Precautions in using a hammer drill**

- Always hold the drill steady and perpendicularly to prevent the bit from breaking or binding.
- Always use a T-handle when drilling to allow you to secure the drill when it encounters hard surfaces.
- Never lock the trigger to "on" position.
- Never drill while not in balance position.
- Always wear eye protection.

## TYPICAL POWER EQUIPMENT

### Parts of a hammer drill

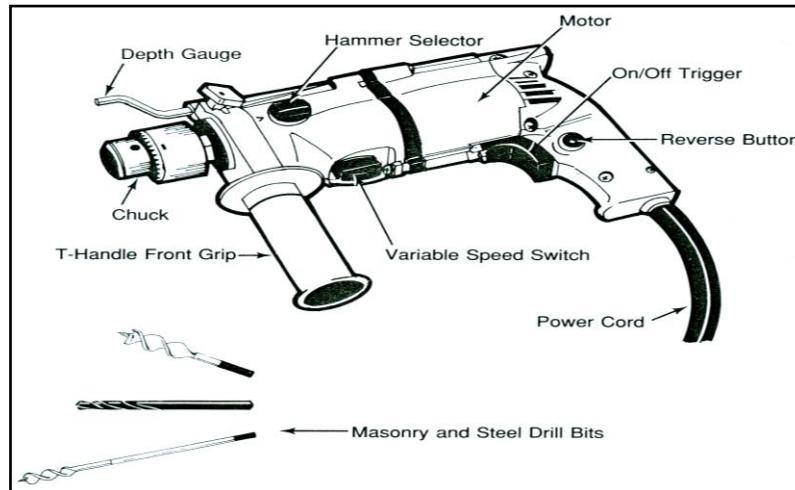

Figure 3. Parts of a hammer drill

### Parts of a core drilling machine



Figure 4 Parts of a core drilling machine

### Safety Precautions in using a core drilling machine

- Ensure that the core drilling machine is securely mounted to the surface to be drilled.
- Never leave the machine drilling unattended.
- Do not force the drill to cut faster than what is suggested by the manufacturer.
- Never drill while not in balance.
- Always wear eye protection.

## Parts of a power drill

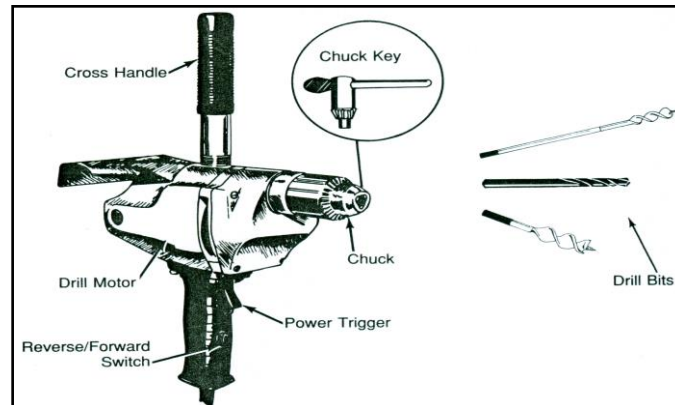

Figure 5 Parts of a power drill

### Safety Precautions in using power drills

- Check the drilling area with possible hidden wires or pipes.
- Hold drill securely with both hands.
- Place small objects to be drilled in a vise.
- Always hold the drill steady and perpendicular to the work to prevent the bit from breaking or binding.
- Always use a T-handle when drilling to allow you to secure the hammer drill when it encounters especially hard surfaces.
- Never lock the trigger to “on” position.
- Never drill while not in balance position.
- Always wear eye protection.

### Portable Power Threader

#### Safety Precautions in Using Portable Power Threader

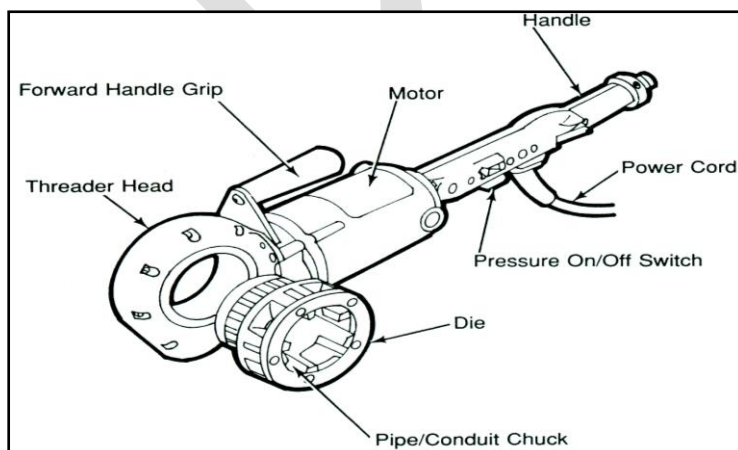

Figure 6. Parts of a Portable Power Threader

If you spend your day operating a drill press thinking that your hand drill may not cause any danger, think again. It is estimated that about 8% of industrial accidents involve the unsafe use of hand tools (both manual and power). These accidents result from using the wrong tool for the job, or using the right tool incorrectly, failure to wear personal protective

equipment, or failure to follow approved safety guidelines. The following checklist provides some basic rules for the safe use of portable power tools. Take a moment to review this list and use the tips here whenever you use a portable power tool.

## **Power Tool Rules**

- Use your tool only for the specific task it was designed for.
- Read the owner's manual before using your tool.
- Never use any tool (power or manual) unless you are trained to do so.
- Inspect before each use and replace or repair if parts are worn out or damaged.
- Inspect screws, nuts, bolts and moveable parts to make sure they are tightened.
- Before plugging or unplugging tools, make sure that the power switch is turned "OFF."
- Never disconnect power by pulling out the cord. Remove the plug from the outlet.
- Never clean or repair a tool in use unless power is disconnected. (Repair tools only if you are trained to do so.)
- When working on ladders or scaffolding, rest power tools on a flat surface or in a bin secured to the ladder itself. (A falling tool can seriously injure a coworker or a bystander)
- Use a ground fault circuit interrupter when working with power tools.
- Avoid wearing of rings, jewelry, or loose clothing when operating power tools.
- Wear Personal Protective Equipment (PPE) such as face shields, safety goggles, disposable masks, and other required PPE

## **Common Defects of Electrical Power Tools**

- 1. Mechanical Parts**
  - a. Chuck – rusted or stock – up
  - b. Bearing – worn – out
  - c. Rotor Shaft – worn – out
- 2. Electrical Parts**
  - a. Switch (lock, reversing and trigger) – defective
  - b. Line cord – open line
  - c. Carbon brush – worn – out
  - d. Rotor winding – shorted / open
  - e. Stator winding – shorted / open

**NOTE:** In servicing electrical power tools, always replace parts according to the manufacturer's specification.

### ACTIVITY SHEET 1.3

#### PREPARE ELECTRICAL POWER TOOLS

Procedure in checking the condition of electrical power tools:

1. Follow the procedure in checking the condition of electrical power tools.
2. Label each power tool and its part as operational or defective.
3. Report to the teacher those defective electrical power tools and the defective parts.
4. Replace the defective parts according to manufacturer's specification.

Direction: Put a check if its part is operational or defective.

Examine each electrical power Tool.  
Electrical Power Tool and Portable Hand Drill

Parts to be checked	Operational	Defective
Mechanical Parts:		
a. Chuck		
b. Bearing		
c. Rotor Shaft		
Electrical Parts:		
a. Switch		
b. Line cord		
c. Carbon brush		
d. Rotor winding		
e. Stator winding		
<i>TOTAL</i>		

### ACTIVITY SHEET 1.4

#### USING ELECTRICAL POWER TOOLS

##### Portable Electric Drill

Name \_\_\_\_\_ Date \_\_\_\_\_ Grade/Sec: \_\_\_\_\_

The student will perform the following while operating the portable electric drill.

		Yes	No
1.	Safety glasses are worn while the portable electric drill is being used.		
2.	The portable drill is unplugged while the drill bit is being changed.		
3.	The drill bit is tight in the chuck, runs true, and the chuck wrench has been removed from the chuck key before the drilling operation begins.		
4.	The portable electric drill is held firmly in both hands as the switch		



	is turned on and as the hole is being drilled.		
5.	The portable electric drill has been stopped from rotating before the drill is laid down.		
6.	The portable electric drill is positioned so that chips are thrown away from the operator and others working in the area.		
7.	The electrical cord and extension cord(s) are positioned away from the work being performed.		
8.	The student can properly select, remove and replace bits on the portable electric drill.		
9.	The correct drill speed is selected for the type of material being drill.		
10.	The student can safely control the portable electric drill and perform satisfactory drill work.		

Comments: \_\_\_\_\_  
 \_\_\_\_\_

I do hereby certify that my student has passed this activity by demonstrating desired abilities in operating the portable electric drill.

Attested:

\_\_\_\_\_  
 Teacher

\_\_\_\_\_  
 Date

### SELF-CHECK 1.1

#### ELECTRICAL TOOLS AND EQUIPMENTS

**A. Direction:** Identify the tool that is being described. Write your answer on a separate sheet of paper.

1. It is used to drive and loosen cross – slotted – screws.
2. It is used to scrape surfaces of conductors and to remove big cables insulation.
3. It is a pipe bending tool with handles of several sizes and lengths.
4. It is a plier commonly used to make terminal loops on copper wire and can reach tight places.
5. it is a hand tool for driving and pulling out nails.

**B. Direction:** On a short bond paper, illustrate the following electrical materials:

1. Fuse
2. Utility box
3. Switch
4. Cable
5. Insulated staple

**SELF-CHECK 1.2**  
**PROPER TOOL STORAGE**

**A. Direction:** On a separate sheet of paper, write T if the statement is correct and F if it is false.

- \_\_\_\_\_ 1. All tools can be used as hammer.
- \_\_\_\_\_ 2. Chisel is an example of boring tool.
- \_\_\_\_\_ 3. Light tools and equipment should be placed at the lowest part of the cabinet shelf.
- \_\_\_\_\_ 4. Tooth cutting tools should be sharpened as often as necessary.
- \_\_\_\_\_ 5. Tools and equipment must be stored according to their kind.

**B. Direction:** Match the tools in column A with their classifications in column B. Write only the letter of the correct answer in your answer sheet.

Tools	Classification
_____ 1. screw driver	A. drilling equipment
_____ 2. claw hammer	B. cutting tool
_____ 3. pliers	C. measuring tool
_____ 4. wire gauge	D. driving tool
_____ 5. power drill	E. measuring and testing

**SELF CHECK 1.3**  
**MAINTENANCE PROCEDURE**

**I. Direction:** Identify what is being referred to in the following sentences. Write your answer on a separate sheet of paper.

- 1. It is an action carried out to restore an item at its acceptable condition.
- 2. It is lanolin or natural water repellent lanolin which is derived from a wool grease and a safe alternative of these more common petro-chemical based lubricants.
- 3. It is performed in order to prevent failures before they develop into a breakdown.
- 4. It is performed in order to correct a failure.
- 5. It is the first step of any preventive maintenance system.

**II. Direction:** Give at least 5 reasons why we need to put lubricants on our tools and equipment.

**SELF-CHECK 1.4**  
**PORTABLE ELECTRIC DRILL**

**Direction:** Identify the parts of a portable electric drill. On your paper the letter of the correct answer.

- A. Chuck
- B. Chuck Wrench
- C. Cord Strain Relievers
- D. Electrical Cord
- E. Pistol Grip
- F. Reversing Switch
- G. Switch Lock
- H. Trigger Switch

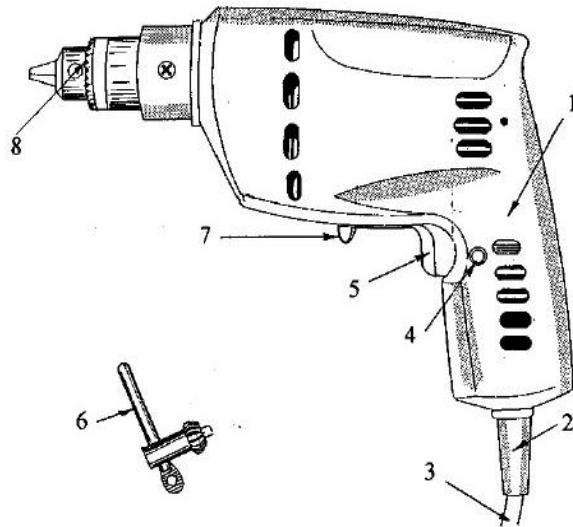

**SELF-CHECK 1.5**  
**PORTABLE ELECTRIC DRILL SAFETY AND PROCEDURE TEST**

Name \_\_\_\_\_ Date \_\_\_\_\_  
Grade/Sec: \_\_\_\_\_

**Multiple Choice:** Read each statement carefully . Then, write the letter of the correct answer in your answer sheet.

1. What is the purpose of turning the drill on before attempting to drill a hole \_\_\_\_\_?
  - a. see if the drill operates.
  - b. see if the drill bit is running true.
  - c. make sure the chuck key has been removed.
  - d. check if the power cord is good
  
2. The purpose of moving the drill and the bit up and down often while drilling deep holes is to \_\_\_\_\_.
  - a. ream the hole slightly larger.
  - b. give the drill operator better drilling leverage.
  - c. help keep the hole centered.
  - d. reduce overheating in the drill bit.

3. What will likely happen if a large capacity portable drill bit jams during the drilling operation?
  - a. The bit will break.
  - b. The drill will rotate in the opposite direction to the bit causing injury to the user's wrist.
  - c. The drill will likely stall out and overheat.
  - d. The hole will become badly distorted.
  
4. What kind of pressure should be applied to a drill during the drilling operation?
 

a. Light, even	c. Moderate, even
b. Medium, even	d. Heavy, even
  
5. What type of drill speed is needed for wood drilling operation?
 

a. Low	c. Medium
b. Low-medium	d. High
  
6. What type of drill speed is needed for most metal drilling operations?
 

a. Low	c. Medium-high
b. Medium-low	d. High
  
7. What is the purpose of a pilot hole when drilling ?
  - a. to make the final hole drilling operation easier.
  - b. To guide the final drilling operation and achieve a more accurately place hole.
  - c. to reduce the feed pressure needed to drill a hole.
  - d. to allow the final hole to be drilled at a faster revolution per minute (rpm) and to finish smoothly.
  
8. What should the operator do to prevent seizing when drilling?
  - a. Reduce the rpm's of the portable electric drill
  - b. Lubricate the drill bit.
  - c. Use a high speed drill bit.
  - d. Reduce the feed pressure when the bit is about to finish drilling.

### **SELF-CHECK 1.6**

#### **PORTABLE DISC GRINDER SAFETY AND PROCEDURE TEST**

Name \_\_\_\_\_  
Grade/Sec: \_\_\_\_\_

Date \_\_\_\_\_

**Multiple Choice:** Read each sentence carefully. Write the letter of the correct answer in your answer sheet.

1. What personal protective equipment should be worn when operating the portable disc grinder?
  - a. Safety glasses
  - b. Safety glasses and hearing protection
  - c. Safety glasses, hearing protection and gloves
  - d. Safety glasses, hearing protection, gloves and respirator.

2. When operating the portable disc grinder, the grinding disk should be positioned so that the sparks and grit are thrown \_\_\_\_\_.
  - a. away from the operator.
  - b. away from the operator and others in the work area.
  - c. up to avoid hitting others.
  - d. down to avoid hitting others.
  
3. Grinding with the portable disc grinder should not be done in an area which \_\_\_\_\_.
  - a. is enclosed.
  - b. is clean.
  - c. has windows.
  - d. contains flammables or combustible gases.
  
4. The grinding disc should be replaced when worn out and reduced to \_\_\_\_\_ of its original diameter.
  - a.  $\frac{1}{4}$
  - b.  $\frac{1}{2}$
  - c.  $\frac{5}{8}$
  - d.  $\frac{3}{4}$
  
5. Hands and arms should be protected by wearing \_\_\_\_\_ when using the portable disc grinder.
  - a. gloves
  - b. long sleeved shirt
  - c. long sleeved leather jacket
  - d. long sleeved leather gloves.
  
6. What may possibly happen when the wire brush attachment is used on the portable disc grinder?
  - a. The grinder may be thrown out from the user's grip.
  - b. The grinder moves back and forth.
  - c. The grinder stays steady on the material being brushed.
  - d. The grinder performs well.
  
7. When the portable disc grinder is laid down, it should be positioned \_\_\_\_\_.
  - a. with the disc down.
  - b. on its left side.
  - c. on its right side.
  - d. on the tool rest with the grinding disc facing up.
  
8. What is the minimum size of the electrical extension cord used with most portable disc grinders?
  - a. #2.0mm<sup>2</sup>
  - b. #3.5mm<sup>2</sup>
  - c. #5.5mm<sup>2</sup>
  - d. #8.0mm<sup>2</sup>

## Maintain Electric and Hydraulic Tools

- Check the conditions of electric and hydraulic tools
- Lubricate electric tools in line with manufacturer's specifications

- Replace auxiliary part of electric and hydraulic tools according to manufacturer's specifications
- Store electric and hydraulic tools

## INFORMATION SHEET 2.1

### PREPARE HYDRAULIC TOOLS

#### Common Parts of Hydraulic Tools

**Hydraulic** means using pressurized fluid oil to accomplish the work.

**Hydraulic oil** is a specially formulated oil for hydraulic pumps.

*(Note: No oil or fluid should ever be used as a substitute for hydraulic oil.)*

**Hydraulic Pump** is used to drive the pressurized oil.

**Ram** is a device used to transfer hydraulic pressure to a mechanical device.

**Hydraulic Pipe Bender** is used for bending conduit at various angles.

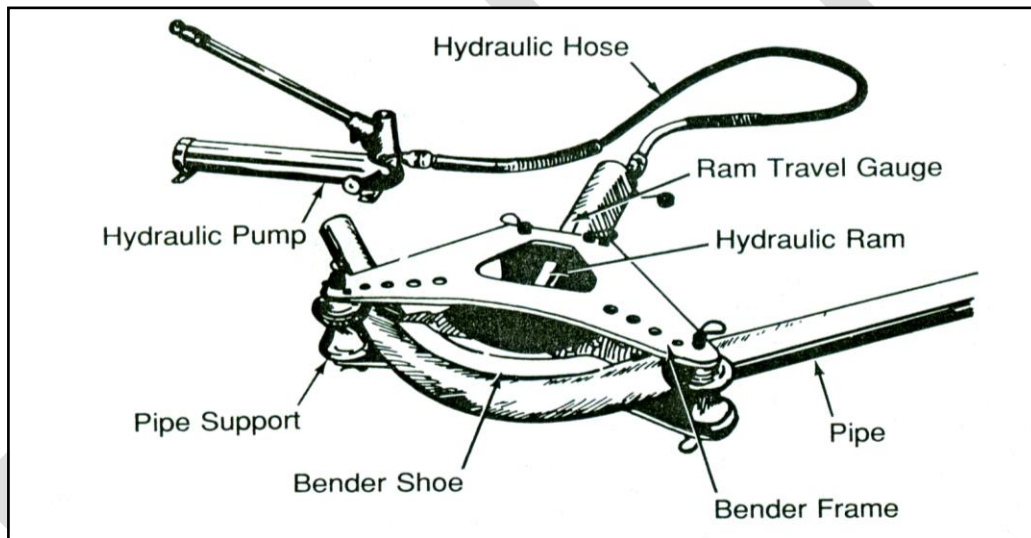

*Figure 1. Parts of a Hydraulic Pipe Bender*

#### Safety rules in using hydraulic pipe bender

- Never substitute brake fluid for hydraulic oil.
- Never disconnect the hose when it is under pressure.
- Never place hands near ram or shoe while bending.
- Always use proper size conduit shoe and support.
- Be sure that floor area is clear for the pipe to move freely.
- Lift heavy bender parts correctly.
- Make sure that the shoe, follow bar, saddle, pipe support, and other accessories are appropriate to the size and the type being bent.

**Hydraulic Knockout Set** is used for boring holes on metal enclosures.

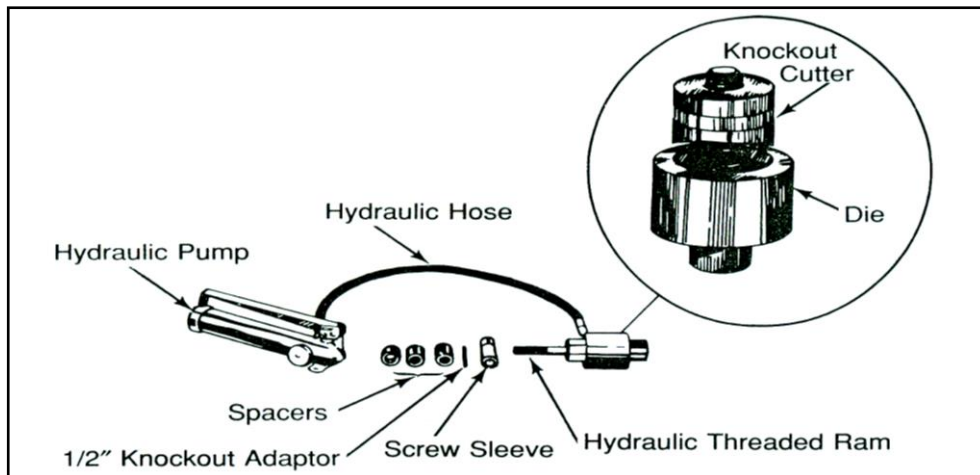

Figure 2. Parts of a Hydraulic Knockout Set

### Safety rules in using hydraulic knockout sets

- Never substitute brake fluid for hydraulic oil.
- Do not come near to live electrical parts.
- Never force the pump handle.
- Always wear eye protection.

**Dieless Hydraulic Crimper** is used for splicing conductor easily.

**Note:** This model has a hinged crimping head for easy splice loading and unloading. The crimper swivel head also rotates 180 degrees for flexibility.

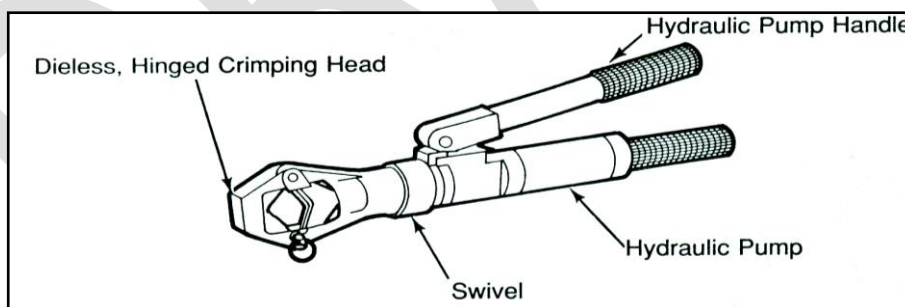

Figure 3. Parts of a Die less Hydraulic Crimper

### Safety rules in using hydraulic crimpers

- Ensure that die is mounted securely on threading machine.
- Keep die flooded with cutting oil during operation.
- Keep hands, clothings, and hair away from rotating parts.
- Always wear eye protection.

## Common defects of hydraulic tools

- Hydraulic pump – leaking
- Hydraulic ram – worn – out shaft
- Hydraulic hose – leaking
- Hydraulic ram travel gauge – worn – out shaft
- Hydraulic oil – inadequate oil

### ACTIVITY SHEET 2.1

#### BENDING A 90-DEGREE STUB USING A HYDRAULIC PIPE BENDER

Name \_\_\_\_\_ Attempt Number \_\_\_\_

Date \_\_\_\_\_ Overall Rating \_\_\_\_

**Instruction:** When you are ready to perform this task, ask your teacher to observe the process and to rate your performance using the specified criteria.

#### Equipment and Materials

- Hydraulic pipe bender
- 5 feet of 1-inch rigid galvanized conduit
- Tape
- Marking pencil
- 

**Procedure (NOTE:** *The procedure below is specified for a Greenlee #880 bender. Other benders may vary in measurements, but the procedure will be basically the same. See figure 1 in the information sheet 2.1)*

1. Assemble hydraulic bender using a 1-inch shoe and pipe support.
2. Check chart on bender for a minimum stub length, required deduction for stub, and a ram travel measurement. Record the data.
  - Minimum stub length = \_\_\_\_\_
  - Stub deduction = \_\_\_\_\_
  - Ram travel = \_\_\_\_\_
3. Mark stub length (24 inches) on a pipe.
4. Subtract stub deduction measurement from 24-inch mark, and make a second mark at that point.
5. Place the pipe on a bender shoe, matching center mark of shoe with second mark on pipe.
6. Close the hydraulic pump valve and pump handle until the ram travel gauge indicates amount of travel for a 1-inch pipe with a 90-degree bend.



7. Release hydraulic pump valve and allow ram to return fully before removing pipe.
8. Check the height of the stub and its accuracy for evaluation.
9. Disassemble bender.
10. Clean the work area.
11. Return the equipment and materials to their proper places.

<b>Assessment Criteria</b>	<b>Yes</b>	<b>No</b>
Appropriate equipment and materials are gathered and used in line with the job requirements.		
The procedure was safely performed.		
The procedure was followed in chronological order.		
Work area was cleaned.		

Teacher's Comments:

---



---



---

## **INFORMATION SHEET 2.2**

### **STORE ELECTRICAL POWER AND HYDRAULIC TOOLS**

#### **Power Tool Safety Rules**

Safety within and outside the shop is important. Teaching young people to respect power tools and take safety procedures to heart represents a continual challenge and a serious responsibility. Some students come to class without any idea what a power tools are. Others have received poor instruction or downright bad advice and mistakenly think they "know what they are doing." It's essential that both groups must gain from you a solid foundation in modern power tool safety practices that they can use in class and throughout their lives. To avoid accidents, power tool operators must be knowledgeable in handling these tools. Inexperienced, untrained, and unprepared operators can be injured within minutes of attempting to use them.

Safety/precautionary measures should always be observed when handling power tools, many of these precautions are common to all. Learn these by heart and you'll always be safe.

- Always read, understand, and **follow** the Instruction Manual before using any power tool. Also read the nameplate information and follow the warning labels of the tool itself.

- **Always** wear safety goggles or safety glasses with side shields. Use a dust mask for dusty operations and wear hearing protection when needed.
- Avoid wearing loose-fitting clothing, no neckties, no jewelry, no dangling objects of any kind. Long hair must be tied back out of your way. Use Non-slippery footwear.
- Make sure your work area is neat and clean and free from any debris that might get in your way or be ignited by hot tools, chips or sparks.
- Make sure your work area is well - lighted.
- Before you plug in any power tool, **make sure the power switch is off.**
- Make sure that all appropriate guards are in place and working.
- Always turn off and unplug the tool before you make any adjustments or changes in accessories.
- Never use any accessory except those specifically supplied or recommended by the manufacturer. They should be described in the tool's Instruction Manual.
- Never use power tools in wet or damp conditions.
- Never use a tool that is damaged or malfunctioning.
- Make sure that the extension cord used is designed for its purpose. If the tool has a three-pronged plug, make sure you use a three-pronged extension cord plugged into a three pronged outlet.
- Never use power tools if you are tired, sick, distracted, or under the influence of drugs or alcohol.
- Make sure cutters or blades are clean, sharp and securely in place. Never use bent, broken, or warped blades or cutters.
- Never overreach while using a power tool. Stay in balance.
- Never rush what you are doing. Be in focus. Don't let anything distract you.
- When using hand-held power tools, always keep a firm grip with both hands. Losing control creates a hazardous situation.
- Always use the right tool for the right job. No substitutions are allowed.
- When done, always unplug, clean, and store the tool in a safe and dry place.

### **Safe Storage of Electrical Power and Hydraulic Tools**

Develop a system of racks, bins and tools panels for safe storing of electrical tools and other materials. Don't store tools, supplies or spare parts in the aisle or on the floor where they become tripping hazards. Keep other flammable materials away from heaters and welding areas to prevent fire. Grease oil, paint, and solvent should be stored in a close metal container, preferably in metal cabinets. Gasoline or other fuels should never be stored inside a shop. Supplies, tools and equipment should be stored in any area designed specifically for them. Electrical power tools should have its own racks or tool panels while hydraulic tools should have its own racks or tool panels.

## **INFORMATION SHEET 2.3**

### **MAINTENANCE PROCEDURE**

Maintenance is an action carried out to retain an item in or to restore it to its functional condition.

Regular maintenance and servicing of power tools and electric tools will help to ensure that they operate with optimum efficiency at all times. This will not only help to keep tool operating costs low but it can also increase tool safety and reliability.

The first thing to do in any preventive maintenance system is to use your eyes, nose, ears, experience, and judgment. Follow your instinct or your keen observation on an equipment when doing preventive maintenance.

#### **Planned maintenance**

1. Preventive maintenance is performed in order to ensure that tools are operating properly and efficiently.
2. Corrective maintenance is performed in order to correct a failure.
3. Emergency maintenance is necessary to put the item at hold immediately to avoid serious consequences such as the loss of production, extensive damage of assets, and for safety reasons.

#### **Sample checklist of tools and equipment**

<b>YES</b>	<b>NO</b>	<b>STORING TOOLS AND EQUIPMENT</b>
		Are the tools stored in proper storage area when not in use?
		Are the defective hand power tools removed from the storage area for repair?
		Are the power equipment turned OFF when not in use or when adjustments are needed?
		Are the tools and equipment kept clean and in good working conditions?
		Are the worn-out, deteriorated or poorly insulated power tools and equipment replaced/repaired?

## **Lubrication**

The following features contribute to safety and economic lubricating machine tools:

1. Plates on machines clearly show the grades of lubricant, quantities and intervals are required. The machine name, type, and model should be visible.
2. Maintain the proper level of lubrication reservoirs.
3. Suitable method of lubrication should be followed to minimize or prevent metal – to – metal contact at all times.
4. Sufficient lubricant capacity is needed to prevent overheating and thermal distortion of machine tool structures.
5. Adequate sealing should be properly observed. Install provision for removal of contaminant collected by the lubricant (e.g., filters).

## **Types of Lubricant**

1. Liquid
  2. Solid
  3. Grease
  4. Paste
- Liquid lubricant. A lanolin or natural water repellent lanolin is derived from wool grease and a safe alternative of those common petro chemical based lubricants. These lubricants are also preventive agents against corrosion.
  - Water. It can also be used as a major component aside from other based oils.
  - Vegetable oils. These are primarily derived from plants and animals.

## **Purpose of Lubricating:**

Lubricating performs the following key functions:

- Keeps movable part apart
- Reduces friction
- Transfers heat
- Carries away contaminant and debris
- Transmits power
- Protects against wear
- Prevents corrosion

## ACTIVITY SHEET 2.2

### CLEANING AND LUBRICATING PLIERS

#### Materials

- Soft rug
- Lubricating oil
- Fine sand paper
- Rust remover

#### Tools

- Lineman's pliers
- Long nose pliers
- Personal protective equipment; gloves, goggles, and dust mask.

#### Procedure

1. Prepare the materials needed.
2. Select/identify stock – up pliers.
3. Wear the appropriate personal protective equipment.
4. Clean the rusty part with a fine sand paper.
5. Wipe out the loosened rust.
6. Apply oil on insulated part especially on the jaw with both handles in upward position to prevent oil to drip down the insulation.
7. Move the handle in “out and in” directions with both hands.
8. Wipe out dirt and excess lubricant.
9. Repeat steps 4 and 5 until the jaw loosened well.
10. Store them in the tool cabinet.
11. Observe good housekeeping.

## ACTIVITY SHEET 2.3

### MAINTAINING TOOLS AND EQUIPMENT

**Direction:** Using the given table below, check/identify the tool defects with the corresponding possible remedies.

#### Supplies

- Activity form
- Pencil

#### Materials

- Lubricants
- Rugs
- Rust remover

#### Tools

- Screw driver
- Files
- Abrasive

Tool defect	Possible remedy	Remarks ( after remedy)
<b>Sample: stock-up pliers</b>	<b>Lubricate the pliers</b>	<b>Functional</b>
1.		
2.		
3.		
4.		
5.		
6.		
7.		
8.		
9.		
10.		

Prepared by:

Teacher

## INFORMATION SHEET 2.4 MANUAL OF SPECIFICATION

Instructional manual is a booklet which serves as a user guide in knowing desirable and undesirable feature of certain product such as electrically operated equipment devices and appliances. Information in the instructional manual typically includes:

- *Safety instruction* which includes warnings and precaution in using the product.
- *Assembly instruction* for dismantling and assembling product in case of repair.
- *Set up instruction* for devices that keep track of time or which maintain user accessible state.
- *Normal usage instruction* for obtaining usual features.



- *Maintenance instruction* for long life use
- *Troubleshooting guide* for separation and maintenance
- *Service location* which contains the location of the factory and the authorized technician to be consulted.
- *Regulatory code* compliance information for approval of regulatory standards.
- *Warranty information* for some agreement and conditions set by company.

## Safety Symbols

Your power tool and its owner's manual may contain "WARNING ICONS" (a picture symbol intended to alert you to, and/or instruct you on how to avoid a potentially hazardous condition). Understanding and heeding these symbols will help you operate your tool better and safer.

### SYMBOLS:



### MEANING:

#### Safety Alert

(Potential Personal Injury Hazards)

#### PROHIBITION

**DANGER:** It indicates an imminently hazardous situation which if not avoided, may result in serious injury or death.

**WARNING:** It indicates a potentially hazardous situation which, if not avoided, could result serious injury or death.

**CAUTION:** It indicates a potentially hazardous situation which if not avoided, may result in minor or major injury.

**CAUTION:** It indicates a potentially hazardous situation which if not avoided, may result in property damage.



**WEAR EYE PROTECTION**



**Read and Understand  
Instruction Manual**

**ACTIVITY SHEET 2.4  
INTERPRETING SPECIFICATIONS**

**Materials:** Manual of Specifications

**Procedure:**

1. The teacher will provide you the copy of the manual containing specification.
2. Make a careful inspection of the given manual.
3. Identify the specific items in the manual.
4. List down the information given in each section of the manual of specifications.
5. Tell the importance of specification in each section of the manual.
6. Fill out the table below with the required information.

<b>Specification of the product</b>	<b>Information given</b>	<b>Importance</b>
Name plate information		
Running Capacity		
Product manufactured		
Product Model		

7. Locate the following information in your manual.
  - Safety information
  - Service Center
  - Product Specification
  - Name of model
  - Set of instruction



## INFORMATION SHEET 2.5

### BASIC LUBRICATION

The function of a lubricant is simple. It reduces friction between moving metal surfaces. A lubricant coats surfaces and resists being displaced by the pressure keeping the metal parts separated. Lubricants also prevent corrosion, block contaminants and can serve as a coolant. A good lubricant flows easily under pressure and remains in contact with moving surfaces. It does not leak out from gravitational or centrifugal forces nor does it stiffen in cold temperatures.

#### There are several types of lubricants:

- **Oils** cover a broad class of fluid lubricants which has particular physical properties and characteristics. Petroleum oils (mineral oils) are made from naphthenic or paraffinic oils. Naphthenic oils contain little wax and their low pour point makes them good lubricants for most applications. Paraffinic oils, on the other hand, are very waxy, which makes them useful for hydraulic equipment and other machineries.
- Ideal for lubricating bearings, gaskets, seals and other moving parts, **greases** consist of an oil or synthetic fluid (~80%), a thickening agent (~10%) and additives (~10%). The consistency of greases is usually ranked by their relative hardness on a scale set by the National Lubricating Grease Institute (NLGI). The softest greases are rated at 000 (which is a flowing liquid) with higher numbers indicating harder grease. Most grease falls in the range between 1 and 4.
- **Solid lubricants** are usually fine powders, such as Molybdenum Disulfide (Moly), graphite and Teflon® (PTFE). They can be used alone, or as additives in grease or dispersions, or as dry film bonded lubricants. Lubricating solids can last longer than unfortified oils and greases because of their ability to form burnished films on surfaces.
- **Rust remover** is used mainly to dissolve rust. It is also use as an excellent cleaner. For example, to remove a rusted bolt, spray remover directly on the bolt, wait for approximately five minutes; and unscrew. For a bicycle chain, apply the rust remover to clean the chain, and then apply a thick lubricant (oil or PL-100). *WD-40* and *Release All* are two of the many brands of rust removers on the market.
- **Dry lubricant** is a product that, although greasy when applied, dries in a few minutes and leaves a protective film. Since it dries rapidly, it doesn't attract dust, so there is no mess. This is why it is recommended to be used on rubber, car door gaskets, handsaws, mitre saw, saw sliders, window sashes, etc. It can also be used on balky wooden drawers, but cabinet makers usually prefer floor wax because it is more durable. JIG-A-LOO is the common brand of a dry lubricant.



Locksmiths also use a dry lubricant, graphite, to free stuck door locks. This product, commonly found in stores, should be applied sparingly into the keyhole, as it is very messy. Graphite lubricant is composed of a fine black powder that no cleaner can remove, so it is wise to protect the door when graphite is applied.

- **Penetrating lubricant.** Its lubricating properties persist even after having removed residues, as it penetrates into metal. It is ideal for door hinges, even the fridge, hard to open pliers, ski bindings, and as it does not hold dirt and dust. The PL-100 is thick and very efficient.



- **Synthetic lubricants** cover a broad category of oils, greases, and pastes of varied properties. Synthetic lubricants are more inert, generate less waste, are capable of a wider range of temperatures and have a longer life than petroleum materials. They are even applicable to elastomers, seals and O-rings.
  - Synthetic oils are used to lubricate instrument bearings, hydraulics, air compressors, gas and steam turbines, and other applications. They have excellent viscosity-temperature characteristics, good resistance to oxidation and an extremely wide operating temperature range.
  - Synthetic greases can last a lifetime, making them very cost-effective. They are chemically inert, and their high thermal stability makes them useful for aerospace, electrical, automotive and other high-tech or industrial applications. Some of these lubricants keep their viscosity in temperatures ranging as high as 550° F and are nonflammable up to 1,200° F.

**Silicones** are very stable and very inert lubricants, which provide a wider range of operating temperatures than non-silicone synthetic lubricants. Other advantages include water repulsion and electrical insulation. Fluorosilicones have a higher resistance to harsh environments and the ability to carry bearing loads.

Lubricant manufacturers can provide technical data sheets on their products to advise you on the best applications of each type of lubricant.

## **Kinds, Uses, and Properties of Cleaning Solvents**

### **Kinds of Cleaning Solvents**

**Solutions** are homogeneous mixture of two or more components; can be gaseous, liquid, or solid. When we speak of a solution, we usually think of a solid dissolved in water. While water is the most common solvent, other liquids are frequently employed as solvents for certain substances – for example wax maybe dissolved in gasoline. The dissolved material in a solution is termed as solute (e.g. wax) while the dissolving medium is called solvent (e.g. gasoline). However, the term can be interchanged depending on which substance is of greater amount.

**Solvent** is a component of a solution that dissolves solute and is usually present in large proportion or amount. It can be classified as polar or nonpolar. Polar solvents are solvents which dissolve or are soluble in water; while nonpolar solvents are solvents which do not dissolve or are insoluble in water.

Solvents that are usually used for cleaning in automotive shops are water, gasoline, kerosene, thinner and detergent soap.

The table below shows the kinds of cleaning solvent based on their solubility in water.

Cleaning Solvents	Solubility in Water	Polar	Nonpolar
a. water	soluble	x	
b. gasoline	insoluble		X
c. kerosene	insoluble		X
d. thinner	insoluble		x
e. detergent soap	soluble	x	

### Uses of Cleaning Solvents

Cleaning Solvents	Uses
1. Gasoline	- It is used to wash oil/greasy tools/ equipment.
2. Diesoline	- It is used to wash oil engine, transmission, and other parts of the vehicle.
3. Kerosene	- It is used to remove dust, grease oil, and paint.
4. Thinner	- It is used to remove spilled paint on the floor, walls and tools.
5. Soap and water	- It is used to wash, clean upholstered furniture such as seats, tables, cabinets.

### Occupational Health and Safety Practices in Handling Cleaning Solvents

Disregarding the basic precautionary measures could lead to eye injury and cuts in using cleaning solvents. You should never use compressed air to clean your clothes, hands or body. The pressure can cause the cleaning solvents and dirt particles to penetrate your skin, resulting in infection and /or blood poisoning.

Do not use compressed air to clean an object immediately after it has been removed from a hot cleaning tank. Rinse the cleaning solvents away with water. Do not use carbon tetrachloride as a cleaning solution. The fumes, when inhaled can

cause serious internal injury and possibly result in death. When steam-cleaning, place the object to be cleaned on a pallet and wear a face shield and rubber gloves for protection against loose debris.

If a job or cleaning task requires the use of gloves, use the appropriate gloves. If you have cut, nicked, or burned yourself, or something has got into your eyes, report immediately to the first-aid person.

Keep all inflammable cleaning solvents in closed tin containers and whenever possible, store them in a separate area.

## **5S (METHODOLOGY)**

**5S** is a reference to a list of five Japanese words translated into English. It is a method of organizing a workplace, especially shared workplaces (like a shop floor or an office space, even in school). It is sometimes referred to as a housekeeping methodology; however this characterization can be misleading because organizing a workplace goes beyond housekeeping.

The key targets of 5S are workplace morale and efficiency. The assertion of 5S is, that time must not be wasted. Additionally, it is quickly obvious when something is missing from its designated location. 5S advocates believe the benefits of this methodology come from deciding *what* should be kept, *where* it should be kept, and *how* it should be kept. This decision making process usually comes from a concept of standardization which builds a clear understanding, among employees how work should be done.

**The 5S's stands for:**

### **SEIRI: SORT (CLEAN UP)**

**This is the first in the 5S program:**

**"Sorting" means to sort everything in each work area.** Keep only what is necessary. Put in a separate storage area materials/tools that are not frequently used and discard the ones that are no longer functional.

**Sorting is the first step in making the work area tidy.** It makes it easier to find the things you need. In the sorting process, you can eliminate broken equipment and tools. It frees up additional space when we discard the things that we no longer need.

Obsolete fixtures, molds, jigs, scrap material, waste and other unused items/materials are disposed.

### **SEITON: SET IN ORDER (ORGANIZE)**

**This is the second step in the Five S program:** Step two is to organize, to arrange or organize everything.

Commonly used tools should be readily available. Storage areas, cabinets and shelves should be properly labeled. Always keep the floor clean and paint floors for you to make it easier to spot dirt, waste materials and scattered parts and tools. Outline areas on the floor to identify work areas, movement lanes, storage areas, finished product areas, etc. Put shadows on tool boards, making it easy to be located.

In an office/school, there should be a designated area for bookshelves for frequently used manuals, books and catalogs. Label the shelves and books so that they can be easily found.

The objective of this step is to put everything in the workplace and properly identified and labeled.

This means that there are two important parts to systematic organization. The first part is putting everything in its proper place and setting up a system so that it is easy to return each item to its proper place. The second part is where good labeling and identification practices are important. Both the equipment/tools and materials you use, as well as their proper storage locations, need to be clearly identified and labeled.

### **SEISŌ: SWEEP (REGULAR CLEANING)**

**Step Three:** requires you to do regular cleaning. Once you have everything from each individual work area up to your entire facility sorted (cleaned up) and organized, you need to keep it that condition. This requires regular cleaning or to go along with our third S, "shining" things up.

Regular, usually daily cleaning is needed or everything will be returned to their original places. This can be done by regular inspection. While cleaning its needed also to inspect the machines, tools, equipment and supplies you work with.

**Regular cleaning and inspection** makes it easy to spot lubricant leaks, equipment misalignment, breakage, missing tools and low levels of supplies. If these minor problems are not addressed they can lead to a serious loss in production.

### **SEIKETSU: STANDARDIZE (SIMPLIFY)**

**Step Four:** is to simplify and standardize our actions so that it will be a habit in our routine.

**The good practices developed in steps 1 through 3 should be standardized** and made easy to accomplish. Develop a work structure that will support the new practices and make them into habits. As you learn more, update and modify the standards to make the process simpler and easier.

One of the hardest steps is **avoiding old work habits**. It is easy to slip back into what you have been doing for years. It gives comfort most of the time for this is part of your habit. Use standards to help people work into new habits that are a part of your Five S program.

**Use labels, signages and banners in the workplace to make people aware of the standards being observed.**

## SHITSUKE: SUSTAIN

**Step Five:** The final step is to continue training and maintaining the standards. Have a **formal system for monitoring the results** of your 5S program. Constant monitoring is crucial at this stage.

**Continue to educate people about maintaining standards.** When there are changes - such as new equipment, new products, new work rules - that will effect your Five S program, make the necessary adjustments to accommodate those changes. Make needed changes in the standards and provide training that addresses those changes.

### Translations and modifications

Often in the west, alternative terms are used for the five S. These are "*Sort, Straighten, Shine, Systemize and Sustain*". "*Standardize*" is used as an alternative for "*Systemize*". Sometimes "*Safety*" is included as 6th S.

- Clear out and Classify
  - Clearing items no longer required
  - Tagging items that may be required and storing away from workplace
- Configure
  - A specific place for specific items
  - "A place for everything and everything in its place"
- Clean and check
  - Identify the cleaning zones and establishing cleaning routines
- Conformity
- Custom and practice
  - Monitoring process adherence
  - Continually validating process
  - Customer satisfaction by doing scientific training to workers
  - Continually focus on man, machine, material and method

Alternative acronyms have also been introduced, such as **CANDO** (Cleanup, Arranging, Neatness, Discipline, and Ongoing improvement). Even though he refers to the ensemble practice as "5S" in his canonical work, **Hirano** prefers the terms Organization, Orderliness, Cleanliness, Standardized Cleanup, and Discipline because they are better translations than the alliterative approximations.

### Practice Good Housekeeping

Good housekeeping is one of the surest ways to identify a safe workplace. You can tell how workers feel about safety just by looking at their housekeeping practices. Good housekeeping is not the result of cleaning up once a week or even once a day. It is the result of keeping cleaned-up all the time. It is an essential factor in a good safety program, promoting safety, health, production, and morale.

Whose responsibility is housekeeping? It is everyone's. Clean work areas and aisles help eliminate tripping hazards. Respecting "wet floor" signs and immediately

cleaning up spills prevents slipping injuries. Keeping storage areas uncluttered reduces the chances of disease and fire as well as slips, trips, and falls. Accumulated debris can cause fires and clutter slows movement of personnel and equipment during fires.

Other housekeeping practices include keeping tools and equipment clean and in good shape or keeping hoses and cables or wires bundled when not in use. Broken glass should be picked up immediately with a broom and dustpan, and never with bare hands. Be aware of open cabinet drawers, electric wires, sharp corners or protruding nails. Unsafe condition should be addressed immediately.

How a workplace looks makes an impression of employees behaviour at work. A visitor's first impression of a business is important because that image affects the amount of business it does. Good housekeeping goes hand-in-hand with good public relations. It projects order, care, and pride.

Besides preventing accidents and injuries, good housekeeping saves space, time, and materials. When a workplace is clean, orderly, and free of obstruction; work can get done safely and properly. Workers feel better, think better, do better work, and increase the quantity and quality of their work.

### **Preventive Maintenance of Electrical Tools and Equipment**

There have been a large number of workplace incidents where workers have been electrocuted or suffered electrical shock or burns while using electrical tools and equipment. Most often, the lack of proper maintenance is the cause of these incidents.

Preventive maintenance is a schedule planned maintenance actions aimed at the prevention of breakdowns and failures. The primary goal of preventive maintenance is to prevent the failure of equipment before it actually occurs. It is designed to preserve and enhance equipment reliability by replacing worn components before they actually fail. Preventive maintenance activities include equipment checks, partial or complete overhauls at specified periods, oil changes, lubrication and so on. In addition, workers can record equipment deterioration so they know when to replace or repair worn parts before they cause system failure. Recent technological advances in tools for inspection and diagnosis have enabled even more accurate and effective equipment maintenance, the ideal preventive maintenance program would prevent all equipment failure before it occurs.

There are multiple misconceptions about preventive maintenance. One such misconception is that PM is unduly costly. This logic dictates that it would cost more for regularly scheduled downtime and maintenance than it would normally cost to operate equipment until repair is absolutely necessary. This maybe true for some components; however, one should compare not only the costs but the long term benefits and savings associated with preventive maintenance. Without preventive maintenance, for example, costs for lost production time from unscheduled equipment breakdown will be incurred. Also preventive maintenance will result in savings due to an increase of effective system service life.

#### **Long term benefits of preventive maintenance include:**

- Improved system reliability

- Decreased cost of replacement
- Decreased system downtime
- Better spares inventory management

The following safety precautions should be adopted to prevent possible electrocution.

**ALWAYS:**

- Test and tag electrical leads, tools and equipment regularly.
- Visually inspect electrical leads, tools and equipment for damage before each use.
- Use safety switches when using electrical tools and equipment.
- Use flameproof electrical tools and equipment in areas where there is the potential for flammable and explosive atmospheres.
- Let competent people repair damaged electrical leads, tools and equipment.

**NEVER:**

- Use damaged electrical leads, tools and equipment.
- Use electrical leads, tools and equipment in damp or wet conditions unless they are specially designed for use in those conditions.
- Place electrical leads in areas where they may be damaged (on the ground, through doorways and over sharp edges).

**PREVENTIVE MAINTENANCE TASKS**

The following tasks should be performed at least every three months:

1. Clean the exterior and the interior of the equipment cabinet, using a vacuum cleaner and/ or a clean cloth.
2. On larger systems clean air filter using a vacuum cleaner to remove accumulated dust or dirt.
3. Visually inspect all wiring and cables for cuts, fraying, deterioration, kinks, strains and mechanical holders. Tape, solder or replace any defective wiring or hooded connectors.
4. Inspect all mechanical security: key switches, indicating lamps, control knobs, fans and data entry keyboards. Tighten or replace them as required.
5. Inspect all modules mounted in panels on I/O slots to insure that each module is securely seated in its connector. Remove and clean any module which may have collected excess dust or dirt.
6. Inspect the power supply for proper voltages and check components such as capacitors or resistors for leakage or overheating. Replace any defective components.
7. Check disk drive for proper speed. Adjust speed according to the manufacturer's specifications.
8. Clean disk drive heads, magnetic tape heads, or optical paper tape reader.



9. Perform all preventive maintenance procedures for each peripheral device included in the system.

### **SELF-CHECK 2.1 SAFETY SYMBOLS**

Direction: Identify the safety symbols. Choose from the options below and then write the letter on your answer sheet.

1. It is used without the safety alert symbol indicating a potentially hazardous situation which, if not avoided, may result in property damage.
2. It indicates an imminently hazardous situation which, if not avoided, may result in death or serious injury.
3. It indicates a potentially hazardous situation which, if not avoided, may result in minor or serious injury.
4. Read and understand the instruction manual.
5. It indicates a potentially hazardous situation which, if not avoided, may result in death or serious injury.
6. Potential Personal Injury Hazards
7. PROHIBITION



**A**



**B**



**C**



**D**



**E**



**F**



**G**



**H**

## SELF-CHECK 2.2

### MANUAL OF SPECIFICATION

Direction: Identify the type of manual to be used under the following situation.  
Write the correct answer on your answer sheet.

- \_\_\_\_\_ 1. There is something wrong with the normal function of the product after warranty period.
- \_\_\_\_\_ 2. Untoward accident has to be prevented using power tools.
- \_\_\_\_\_ 3. One week after purchasing of the products, trouble has occurred.
- \_\_\_\_\_ 4. Dismantled parts need complete assembly after the repair.
- \_\_\_\_\_ 5. Determine if the product has passed the quality standards.

### SELF - CHECK 2.3

#### BASIC LUBRICATION

I. Direction: Identify the type of lubricant that is needed. Write, "RUST REMOVER", "SOLID LUBRICANT", "OIL", "GREASE", AND PENETRATING LUBRICANT" on your answer sheet.

- \_\_\_\_\_ 1. Removing rust from bolts, hand tools, bicycle chain and equipment parts.
- \_\_\_\_\_ 2. Maintaining heavy structures like garage door or gate and other related tasks.
- \_\_\_\_\_ 3. Application of maintenance activity for common hand tools, equipment and other hardware.
- \_\_\_\_\_ 4. Recommended to be used on rubber, car door gaskets, and window sashes.
- \_\_\_\_\_ 5. Maintenance for stock-up parts like bearing, bushing, and heavy bolts and nuts.

II. Direction: Identify the following information by writing "ALWAYS" and "NEVER" before each number. Use separate sheet for your answers.

- \_\_\_\_\_ 1. Perform regular check or the condition of tools, instrument and equipment.
- \_\_\_\_\_ 2. Place electrical leads in areas where they can be damaged.
- \_\_\_\_\_ 3. Assign competent people to repair damaged electrical leads, tools and equipment.
- \_\_\_\_\_ 4. Decrease cost of replacement.

- \_\_\_\_\_ 5. Test and tag electrical tools and equipment regularly.
- \_\_\_\_\_ 6. Use damaged electrical leads, tools and equipment.
- \_\_\_\_\_ 7. Use safety switches when using electrical tools and equipment.
- \_\_\_\_\_ 8. Improved system reliability.
- \_\_\_\_\_ 9. Apply preventive maintenance on tools and equipment to prevent electrocution.
- \_\_\_\_\_ 10. Use electrical leads, tools and equipment in damp a wet condition.

**SELF - CHECK 2.4**  
**BASIC LUBRICATION**

**Direction:** Read the instruction in each sub-test. Write your answer on a separate sheet of paper.

**A.** Classify the following cleaning solvents as Polar or Nonpolar. Write P for polar and NP for nonpolar.

- 1. water
- 2. gasoline
- 3. kerosene
- 4. diesoline
- 5. thinner
- 6. detergent soap

**B.** Identify the cleaning solvents used in the following substances.

- 1. Polar substances
  - a. dust
  - b. mud
- 2. Nonpolar substances
  - a. oil
  - b. grease oil

**C.** Match each cleaning solvent with its uses. Write the letter of your answer.

<b>Uses</b>	<b>Cleaning Solvents</b>
1. It is used to clean upholstery and other furniture.	A. alcohol
2. It is used to wash out spilled paint on the floors and walls as well as on the tools/ equipment.	B. diesoline
3. It is used to wash out oil, and grease from tools and equipment.	C. gasoline
4. It is used to remove dust, grease and oil.	D. kerosene
	E. soap and water

5. It is used to clean oil engine, transmission and other parts of the vehicle. F. thinner

**D.** Write only the letter of your answer on the answer sheet provided.

1. Which of the following injuries will be caused by compressed air if used to clean clothes, hands or body soiled with a flammable cleaning solvent?  
a. pimples                      b. burn                      c. blood poisoning
2. Which of the following solvents should not be used as a cleaning solution for it poses hazards to health?  
a. gasoline                      b. kerosene                      c. carbon tetrachloride
3. As a safety precaution, which of the following safety devices should be worn in electrical wiring ?  
a. face shield                      b. rubber gloves                      c. apron
4. Which of the following should we use to keep a flammable cleaning solvent?  
a. closed tin container      b. plastic pail                      c. aluminum basin

## **V. SUMMATIVE TEST**

### **Test I – Multiple Choice**

**Direction:** Write the letter of the correct answer in your answer sheet.

1. What measuring device is used by an electrician to measure value of voltage, current, and resistance?  
a. Volt-Ohmmeter                      c. Megger  
b. Multi-tester                      d. Drilling Equipment
2. These are electrical materials in which splices and joints are being made.  
a. Utility box                      c. Square Box  
b. Junction box                      d. Electrical Boxes
3. What action can be carried out to retain an item or to restore it to a functional condition?  
a. repair and maintenance                      c. corrective maintenance  
b. emergency maintenance                      d. Maintenance
4. It is an electrical device used in controlling the flow of current in a circuit or even the entire circuit.  
a. Flush type switch                      c. Main switch  
b. Tumbler switch                      d. Switches
5. Electrical conductors which is single, usually cylindrical, flexible strand or iron rod of metal.  
a. Stranded conductor      b. Wires      c. Cables      d. Conductors

6. Which of the following should we use to keep a flammable cleaning solvent?
  - a. closed tin container
  - b. plastic pail
  - c. aluminum basin
7. As a safety precaution, which of the following safety devices should be worn in electrical wiring ?
  - a. face shield
  - b. rubber gloves
  - c. Apron
8. Which of the following solvents should not be used as a cleaning solution for it poses hazards to health?
  - a. gasoline
  - b. kerosene
  - c. carbon tetrachloride
9. What can the operator expect to happen when the wire brush attachment is used on the portable disc grinder?
  - a. The grinder may be jumped out or be thrown out.
  - b. The grinder moves back and forth.
  - c. The grinder stays steady on the material being bushed.
  - d. The grinder performs well.
10. Why is it necessary to tighten the disk lock nut snugly only when the disc is replaced on the portable disc grinder?
  - a. The threads will be stripped on the spindle.
  - b. The disc may be too difficult to remove next time.
  - c. The natural rotation of the disc and spindle will cause the threads to tighten.
  - d. The loose threads are allowed to hold some of the vibration created by the portable disc grinder.

### Test II – Identification

**Direction:** Identify what is being described in each of the following sentences. Write your answer on a separate sheet of paper.

1. It is used to drive and to pull out nails.
2. It is commonly used to make terminal loops on copper wire and can reach tight places.
3. It is used to scrape surfaces of conductors and to remove big cables insulations.
4. It is performed in order to correct a failure.
5. It is performed in order to prevent failures before they develop into a breakdown.
6. An accident that has to be prevented when using power tools.
7. What we look at if the product has passed the quality standards?
8. What should you do when there is something wrong with the normal function of the product after warranty period?
9. What should you do when malfunction or trouble has occurred a week after purchasing the products?
10. It is an action carried out to retain or restore an item at an acceptable condition.