



Republic of the Philippines  
**DEPARTMENT OF EDUCATION**



# **K to 12 Basic Education Curriculum Technology and Livelihood Education Learning Module**



# **AQUACULTURE**

***EXPLORATORY COURSE***

***Grade 7 and Grade 8***

## TABLE OF CONTENTS

What Is This Module About ? .....	2
How Do You Use This Module .....	3
LESSON 1 – Use Farm/Fishery Tools and Equipment.....	4-57
LESSON 2 – Perform Estimation and Basic Calculation .....	58-84
LESSON 3 – Draw the Layout Plans for Ponds, Tanks, Pens and Cages.	85-142
LESSON 4 – Apply Safety Measures in Farm Operations.....	143-179
ANSWER KEYS.....	180-185
Acknowledgment.....	186



## What Is This Module About?

Welcome to the world of **Aquaculture!**

This Module is an exploratory course that leads you to **Aquaculture** National Certificate Level II (NC II)<sup>1</sup>. It covers the four (4) common competencies that a Grade 7 / Grade 8 Technology and Livelihood Education (TLE) student like you ought to possess, namely:

- 1) Using farm/fishery tools and equipment
- 2) Performing estimation and basic calculation
- 3) Drawing the layout for ponds, tanks, pens and cages
- 4) Applying safety measures in farm operations.

These four (4) common competencies are covered separately in four (4) Lessons. As shown below, each lesson is directed toward the attainment of one or two learning outcomes:

Lesson 1 – Use Farm/Fishery tools and equipment

- LO1. Select and use farm tools
- LO 2. Select and operate farm equipment
- LO 3. Perform preventive maintenance

Lesson 2 – Perform estimation and basic calculation

- LO 1. Perform estimation
- LO 2. Perform basic workplace calculations

Lesson 3 – Draw the Layout for ponds, tanks, pens and cages

- LO1. Draw layout plan for ponds
- LO2. Draw layout plan for tanks
- LO3. Draw layout plan for pens and cages

Lesson 4 – Apply safety measures in farm operations

- LO 1. Apply appropriate safety measures
- LO 2. Safe keep / dispose tools, materials and outfit

Your success in this exploratory course on **Aquaculture** will be shown in your ability to perform the performance standards found in each learning outcome.

---

<sup>1</sup>NATIONAL CERTIFICATE (NC) is a certification issued to individuals who achieved all the required units of competency for a national qualification as defined under the Training Regulations. NCs are aligned to specific levels within the PTQF. (TESDA Board Resolution No. 2004-13, Training Regulations Framework)

NATIONAL CERTIFICATE LEVEL refers to the four (4) qualification levels defined in the Philippine TVET Qualifications Framework (PTQF) where the worker with:

- a. NC I performs a routine and predictable tasks; has little judgment; and, works under supervision;
- b. NC II performs prescribed range of functions involving known routines and procedures; has limited choice and complexity of functions, and has little accountability;



## How Do You Use This Module?

This Module has four (4) lessons. Each lesson has the following parts.

- Learning Outcomes
- Performance Standards
- Materials/Resources
- Definition of Terms
- What Do You Already Know?
- What Do You Need to Know?
- How Much Have You Learned?
- How Do You Apply What You Learned?
- How Well Did You Perform?
- How Do You Extend Your Learning?
- References

To get the most from this Module, you need to do the following:

1. Begin by reading and understanding the Learning Outcome/s and Performance Standards. These tell you what you should know and be able to do at the end of this Module.
2. Find out what you already know by taking the pretest, and then check your answer against the answer key. If you get 99 to 100 per cent of the items correctly, you may proceed to the next lesson. This means that you need not go through the lesson because you already know what it is about. If you failed to get 99 to 100 per cent correctly, go through the lesson again and review especially those items which you failed to get.
3. Do the required learning activities. They begin with one or more Information Sheets. An Information Sheet contains important notes or basic information that you need to know.  
After reading the Information Sheet, test yourself on how much you learned by means of the Self-check. Refer to the answer key for correction. Do not hesitate to go back to the Information Sheet when you do not get all test items correctly. This will ensure your mastery of basic information.
4. Demonstrate what you learned by doing what the activity / operation /job Sheet directs you to do.
5. You must be able to apply what you have learned in another activity or in a real life situation.
6. Accomplish the scoring rubrics for you to know how well you performed.

Each lesson also provides you with references and definition of key terms for your guide. They can be of great help. Use them fully.



If you have questions, ask your teacher for assistance.

## LESSON 1

### Use Farm/Fishery Tools and Equipment



#### LEARNING OUTCOMES:

At the end of this Lesson, you are expected to do the following:

- LO 1. select and use farm tools
- LO 2. select and operate farm equipment
- LO 3. perform preventive maintenance



## Definition of Terms

<b>equipment</b>	instruments needed in performing a service; the set of articles or physical resources serving to equip a person or things; an instrument used in an operation or activity.
<b>hammer</b>	most popular and the commonly used type of hand tool for driving nail and other protruding materials.
<b>hand tools</b>	hand operated tools.
<b>maintenance</b>	means of improving the performance and condition of equipment and facilities.
<b>pliers</b>	a hand tool of various shape having a pair of pivoted jaws, used for holding, bending, or cutting.
<b>refractometer</b>	instrument for measuring the refractive index of a substance.
<b>screwdriver</b>	a tool used for turning screws to drive them into their place.
<b>shovel</b>	a tool with a handle and a broad scoop or blade for digging or excavation.
<b>sickle</b>	a curved, hand-held farm tool typically used for harvesting grain crop or cutting grass for hay.
<b>tools</b>	devices that facilitate work; the term specifically denotes a small manually operated device.
<b>water pump</b>	a mechanical device that moves fluid or gas by pressure or suction.
<b>wrenches</b>	a hand tool, often having fixed or adjustable jaws, used for gripping, turning, and fastening, tightening, twisting, or loosening objects.

## **LEARNING OUTCOME 1**

**Select and use farm tools**

## **PERFORMANCE STANDARDS**

- Appropriate farm/fishery tools are identified according to requirements.
- Farm/fishery tools are checked for faults and defective tools are reported in accordance with farm procedures.



## What Do You Already Know?

Let us determine how much you already know about the use of farm tools and equipment. Take this test.

### Pretest LO 1

**Directions:** Circle the letter of the correct answer.

1. A device used to strike or deliver blows to an object like driving nails, fitting parts, and breaking up objects.  
A. hammer  
B. plier  
C. wrench  
D. cutter
2. This is the most popular type of measuring tools, it usually is 6 or 12 inches in length.  
A. ruler  
B. speed square  
C. folding ruler  
D. try square
3. It is a curved and handheld aquaculture tool for harvesting grain crops or cutting grasses for hay.  
A. shovel  
B. rake  
C. sickle  
D. mattock
4. The most versatile and widely used shovel, used for digging, scooping, or shoveling dirt from one point to another.  
A. irrigation shovel  
B. round point shovel  
C. garden shovel  
D. scoop shovel
5. A device for measuring the weight of an object  
A. paper weight  
B. measuring tool  
C. weighing scale  
D. square
6. Which of the following measures is not in accordance with the proper care of hand tools?  
A. Clean your tools after use.  
B. Tools should be kept in tool box or a tool cabinet.  
C. When rust form on tools, remove it by using a fine abrasive cloth.  
D. Store hand tools in a wet, sheltered environment.
7. It is a tool used for measuring the distance between two symmetrically opposing sides. It can be like a compass, with inward or outward facing points and the tips can be adjusted to fit across the points to be measured.  
A. caliper  
B. folder ruler  
C. ruler  
D. square



8. Quality indicators of using screwdrivers
- A. bade metal
  - B. handle and bar attachment materials
  - C. screwdriver tips
  - D. all of the above
9. The following are guidelines for avoiding hand-tool injuries except:
- A. right tool for the job
  - B. good condition
  - C. proper storage
  - D. watch your body
10. A tool used to tighten or loosen screws
- A. hammer
  - B. screwdriver
  - C. wrench
  - D. pliers



## What Do You Need To Know?

Read the Information Sheet 1.1 very well then find out how much you can remember and how much you learned by doing Self-check 1.1.

Information Sheet 1.1

### Farm/Fishery Tools

There are varieties of hand tools, designed for specific purposes. They are available in various types, shapes, and sizes with different degrees of hardness and varying configurations for specific purposes.

1. Hand tools are used throughout the world by industry, railroads, foundries, contractors' carpenters, automotive body men and hundreds of others, including home repair services.
2. Each hand tool is designed for a particular job and should be used for those purposes only.
3. Using a tool for something other than its intended purpose leads to possible damage to the tool and can cause discomfort, pain, or injury.

### **Classification of Hand Tools According to Requirement/Use**

Hand tools can be classified into four different sections according to various purposes and uses.

1. **Cutting, Pinching, Gripping Tools** - These tools are used for cutting, pinching, and gripping purposes. Cutting tools are used not only to cut a physical object into pieces, but also used to remove metal or wood from the work piece by means of sheer deformation, and for gripping objects by using leverage. Examples are pliers and cutters.

2. **Striking Tools** - These are the most widely used tools and most often abused. Chiseling, punching, and riveting can be done properly using striking tools. Hand-held striking tools have been used in a variety of disciplines as leveraged devices that provide a striking force to complete an endless variety of tasks. Examples are hammers and chisels.

3. **Driving Tools** - These are tools designed to insert, tighten, loosen, remove screws, bolts, nails, and other pointed objects or hard turn items by applying torque. Examples are screwdrivers, nut drivers, hand wrenches, and T-handle wrenches.

4. **Struck or Hammered Tools** - These tools are used for forcing a bolt, pin, or rivet in or out of a hole. Examples are punches, nail sets, and chisels.

## Different Kinds of Hand Tools

### A. Pliers

Pliers are a comparatively modern invention. They are popular hand tools used for gripping objects through leverage. They have a pair of pivoted jaws used for holding, bending, turning, gripping or cutting various things. They have different jaw configurations depending on their usage. Top quality pliers are forged from fine-grain tool steel, machined to close tolerances with hand-honed cutting edges properly hardened. They are polished, adjusted, and inspected. Pliers vary in length from 4 inches to 20 inches. Every tool user makes use of pliers of various types.

#### Types of pliers

There are different types and sizes of pliers. Each plier is designed for a specific purpose although their versatility makes them suitable for many jobs.

1. **Slip-joint pliers** are great for tightening. They have a joint which can be used for two different width openings. They are the most common type of pliers used at home.



Slip-joint

2. **Groove-joint pliers** similar to slip-joint pliers, have several joints for accommodating jobs calling for various sizes. They are also referred as “Channel lock.”



Groove-joint plier

3. **Parrot nose wrench pliers** are noted for their grip. They are a combination of pliers and a pipe wrench, with 75° offset nose. These kinds of pliers are ideal for pipes and tubings.



Parrot nose wrench plier

4. **Plumber's special pliers** are available with smooth jaws or jaws covered with a soft material to prevent scratching when used on plated plumbing fixtures.



Plumber's special plier

5. **General utility or water pump pliers** are all-purpose pliers with as many as five jaw-opening adjustments. Their teeth are shaped for positive grip on round objects.



Water pump plier

6. **Needle-nose pliers** are used for reaching places with restricted clearance. These kinds of pliers have a pointed nose and may have side cutters. They are typically used for all electrical and electronics works.



Needle-nose plier

## B. Wrenches

A wrench is a hand tool often having fixed or adjustable jaws used for gripping, turning, and fastening, tightening, twisting or loosening objects such as nuts, bolts, or pipes and pipe fittings. A wrench is mainly used to hold and turn nuts, bolts, caps, screws, plugs, and various threaded parts.

### Classification of wrenches

Wrenches are available in various shapes and sizes and are of two kinds:

1. **Pipe wrenches** are used in plumbing for gripping round or cylindrical things.
2. **General-use wrenches** are used on bolts and nuts that have flat and parallel surfaces, such as square or hexagonal.

### Types of wrenches

Depending on whether the wrench is fixed or adjustable, there are different types of wrenches used for different purposes.

1. **Combination wrench** is a double-ended wrench with one end that looks like an open-end wrench and the other end like a box-end wrench. Both ends usually fit the same size or bolt. They are made in metric and standard sizes.



Combination wrench (CBLM-Fish Culture 2<sup>nd</sup> Year)

2. **Adjustable wrench** is used for tightening or loosening nuts and bolts. It has movable lower jaw to adjust wrench size, depending on the size of the nuts or bolts.



Adjustable wrench (CBLM-Fish Culture 2<sup>nd</sup> Year)

3. **Socket wrenches** are like closed-end wrenches but they are cylindrical in shape. They can easily fit over a nut in a recessed hole, which otherwise cannot be accessed by open or closed-ended wrenches.



Socket wrench (CBLM-Fish Culture 2<sup>nd</sup> Year)

4. **Flare-nut wrench, tube wrench, or line wrench** are almost same as box-end wrenches and are used for gripping the nuts on the ends of tubes. They have narrow openings to allow the wrench to fit over the tubes.



Flare-nut wrench (CBLM-Fish Culture 2<sup>nd</sup> Year)

### C. Hammers

The most popular and the commonly used type of hand tool is the hammer. Hammers are used to deliver blows to an object or to strike another object, such as when one is driving nails, fitting parts and breaking up objects. They are available in various shapes and structures and are designed for specific purposes. They consist of a handle to which a heavy head, usually made of metal, is attached.

#### Types of Hammers

1. **Curved Claw Hammer** is used for nail pulling and general carpentry work.



2. **Straight Claw Rip Hammer** is mainly used for general and heavy carpentry work, ripping, and framing.



3. **Ball Peen Hammer** is used for bending or shaping soft metal, for riveting, and for center punching. This type of hammer has a round face with beveled edges and the other end has a ball-shaped peen for metal working.



4. **Hand Drilling Hammer** is designed to do powerful jobs like striking masonry nails, steel chisels, and masonry drills.



## D. Screwdrivers

Screwdrivers are used for turning screws so as to drive them into their place. They have a thin end that enters the nick in the head of the screws, and have a mechanism for the application of torque (force by rotating the tip/end) which drives the screw into its place. Screwdrivers are available in a variety of shapes, and the tip of the driver can be rotated manually or electrically.

There are some other varieties of screwdrivers that are very popular in the market today. These are the magnetized tip screwdrivers. They have magnetized tips, and the blades can range from Philips to Hex and other types. These are convenient when guiding screws to holes or into inaccessible areas. They can also be used to retrieve dropped screws and nuts.



### Types of Screwdrivers

These are common screwdrivers with their uses and features.

1. **Philips** has a crossed slot with a flat tip. It is used for tightening and loosening Philips' head screws and bolts.



2. **Standard (slotted)** has a single slotted tip which is flared to the sides above the tip. It is used for tightening and loosening slotted screws and bolts.



3. **Clutch Head** is used for tightening and loosening clutch head screws and bolts. It has four points of contact and locks into the screw head when turned counterclockwise.



4. **Nut Driver** comes in various sizes, from 3/16 inch to 1/2 inch. It is used for tightening and loosening hexagonal screws and bolts.



## E. Measuring Tools

These tools are used for measuring dimensions. Measuring tools are imperative for implementing any work with precision and carrying out different types of measurement.

Measuring tools are important in examining a finished product or semi-finished product. Inspection or examination operation entails checking if the actual object/piece meets the required dimensions for that piece according to a diagram or sketch. Again, the measurements taken must be accurate. Accuracy of measurements depends on one's ability to use measuring tools correctly. It is not only necessary to know precisely how many feet and inches are involved, but also to make sure that everything comes out in exactly the size that one requires.

## Types of measuring tools

Below are descriptions of popular measuring tools.

1. **Squares** are indispensable to woodworkers, carpenters, machinists, tile setters, and anyone who needs to make their projects with precision. Squares comprise a group of tools that come in a wide variety of shapes and sizes, depending on their intended use.

A **Try square** is an L-shaped square having a handle and a thin metal blade marked in graduations like a scale/ruler. This square is used basically to mark a straight line across a wood piece for cutting.



3. **Rules** are the most popular type of measuring tool. Rules usually come in lengths of 6 or 12 inches. The rules or ruler are made of wood, metal or plastic. It is to be noted that the thinner the rule, the easier it is to obtain accurate measurement with it.

4. **Caliper** is a tool used for measuring the distance between two symmetrically opposing sides. It can be like a compass with inward or outward facing points and the tips can be adjusted to fit across the points to be measured. When the caliper is removed, the distance between the tip is measured using a ruler.



## Choose the Right Tool for the Job

1. **Round point shovel** - The most versatile and widely used shovel. It is used to dig, scoop or shovel dirt from one point to another.



2. **Garden shovel** – It has the same general design as a round point shovel, but it is smaller and lighter. It is used for lighter tasks and suit less muscular persons.



3. **Scoop shovels** are used to move light materials such as sawdust or dried manure. It isn't advisable to use for moving heavy, wet materials—given the large volume the shovel can hold, the weight of such materials may strain on one's back, leading to a backache.



4. **Barn forks** have long angled tines. It is used for moving hay, garden pruning, weeds, and other organic materials.



5. **Spading fork** performs a multitude of garden tasks. Primarily, it is used for tilling the soil and breaking up heavy dirt clods. It is invaluable in weeding large areas where there is no danger of injuring the roots of desirable plants. It comes



in many sizes; with long or short handles; different tine lengths; and number of tines. The tines of less expensive brands tend to bend so it is worth investing on quality tools/tines.

6. A **Bow rake** is traditionally called “steel rake”. Its head may be anywhere from 8 inches to 24 inches wide. The head is connected to the handle by a steel ‘bow’ at each end. These bows act as shock absorbers, giving this tool the strength to do serious raking of heavier materials



7. A **Level head rake** is much the same as a bow rake, except that the back of the head is straight and even, and connects to the handle in the center. Its straight edge is used for leveling seed beds. The corners may also be used for creating furrows.



8. A **Trowel** is a constant companion at different times of the year. These little shovels are in valuable during planting season. You may wish to have a couple of different trowels for different uses.



9. A **Pick and mattock** is used for serious digging through hard packed soil and clay. The pick (pointed end) or the mattock (wide blade) is used to chop down, into the soil, and the cradle design of the head can then be used as a lever to break open the soil, allowing for easy shoveling.



10. A **Pruning saw** has cutting teeth larger than a normal saw for quick cuts through branches and limbs over an inch in diameter. Always ‘undercut’ the branch before making the final top cut to avoid damage to the bark of the tree or shrub.



11. **Sickle** is a curved, hand-held farm tool typically used for harvesting grain crop or cutting grass for hay. The inside of the curve is sharp, so that the user can draw or swing the blade against the base of the crop, catching it in the curve and slicing it at the same time.



12. **Secchi disk** is used to measure water turbidity. The reading is sometimes called Secchi Disk transparency. Productive ponds usually have a Secchi Disk Transparency depth between 10 to 30 centimeters.



*Procedures in measuring Secchi Disk transparency*

1. Lower the disk slowly into the water.
2. Stop exactly when it just disappears from sight.
3. Note at which point the line breaks the water surface. Mark this point A.



4. After noting the point along the line where the disk disappears, lower the disc a little more, and then raise it until it reappears. Mark this point B.
5. Mark point C, midway between points A and B.
6. Measure the transparency of the water as equal to the distance from the top of the disk to this point C, counting the knots along the line. This value is the Secchi Disk Transparency in centimeter.

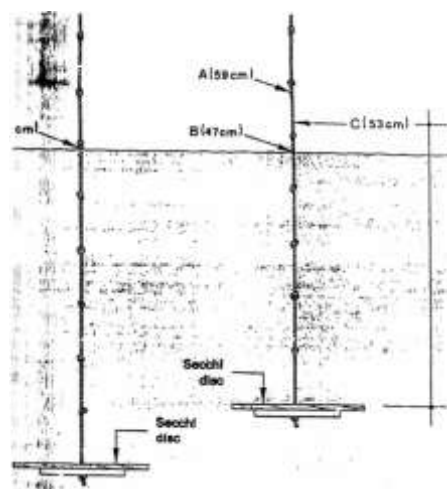

Secchi disk readings (CBLM-Fish

Culture IV page 43)

### Caring for Your Farm Tools

When you are purchasing new farm tools, you will more than likely have a choice between low-priced and high-priced tools. Quality tools are designed to last for years but they must be cared for and maintained. Maintaining your farm tools on a regular basis assures that they are ready to be used on your next chore. Following these basic rules to maintain and care for your tools.

- Always remove all the soil from your digging tools after use. Hosing is usually all it takes, but use a screwdriver to remove dried mud.
- Never put your tools away wet. Allow them to dry completely before storing to prevent rusting and handle rot.
- After use, wipe the metal parts of pruners, shears, and loppers with an oily rag. Alternately, you can wipe your tools dry with a clean rag, and then spray lightly with a penetrating oil such as WD40.
- Regularly sharpen your cutting tools as well as the blades of shovels and spades during the gardening season. A hone or whetstone should be used for sharpening cutting tools. A file should be used to remove nicks and smoothen the edge of your shovels and trowels.
- Thoroughly clean any tools that have been used for chemical applications. Fertilizers and other chemicals will rapidly corrode any metal parts.
- For extra rust prevention, fill a 5-gallon bucket with builder's sand and pour a quart of new motor oil over it. Use this as a shovel cleaner/oiler each time you put your tools away. Push each tool into the oily sand several times. You can also use this bucket as a shovel stand.

### Safety Measures in Using Farm Tools According to Job Requirement

Hand tool injuries are common, though hand tool injuries tend to be less severe than power tool injuries. Because people take ordinary farm tools for granted, they forget to follow simple safety precautions.

The most common farm tool accidents are caused by the following:

- Failure to use the right tool.
- Failure to use a tool correctly.
- Failure to keep edged tools sharp.
- Failure to replace or repair a defective tool.
- Failure to store tools safely.

Follow these guidelines for general farm tool use:

- Wear safety glasses whenever you hammer or cut, especially when working with surfaces that chip or splinter.
- Do not use a screwdriver as chisel. The tool can slip and cause a deep puncture wound.
- Do not use a chisel as screwdriver. The tip of the chisel may break or cause an injury.
- Do not use a knife as a screwdriver. The blade can snap and injure an eye.
- Never carry a screwdriver or chisel in your pocket. If you fall, the tool could cause a serious injury. Instead, use a tool belt holder.
- Replace loose, splintered, or cracked handles. Loose hammer, axe, or maul heads can fly off defective handles.
- Use the proper wrench to tighten or loosen nuts. Pliers can chew the corners off a nut.
- When using a chisel, always chip or cut away from yourself. Use a soft-headed hammer or mallet to strike a wooden chisel handle. A metal hammer or mallet may cause the handle to split.
- Do not use a wrench if the jaws are sprung.
- Do not use impact tool, such as chisels, wedges, or drift pins if their heads are mushroom shaped. The heads may shatter upon impact.
- Direct saw blades, knives, and other tools away from aisle areas and other employees.
- Keep knives and scissors sharp. Dull tools are more dangerous than sharp tools.
- Iron or steel tools may produce spark and can be hazardous around flammable substances. Use spark-resistant tools made from brass, plastic, aluminum, or wood when working around flammable substances.



## How Much Have You Learned?

### Self-Check 1.1

**Directions:** Identify what is being described or defined:

- \_\_\_\_\_ 1. This is used not only to cut a physical object into pieces but also to remove metal or wood from the work piece by means of shear deformation. These objects use leverage.
- \_\_\_\_\_ 3. This is a hand tool, often having fixed or adjustable jaws, used for gripping, turning, and fastening, tightening, twisting or loosening objects.
- \_\_\_\_\_ 4. This is used to deliver blows to an object or strike another object, such as when one is used for driving nails, fitting parts and breaking up objects.
- \_\_\_\_\_ 5. This is a tool used for turning screws so as to drive them into their place.
- \_\_\_\_\_ 6. These are essential tools for examining a finished product or semi-finished product.
- \_\_\_\_\_ 7. These are used to measure water transparency.
- \_\_\_\_\_ 8. This is a curved, hand-held farm tool typically used for harvesting grain crops or cutting grass for hay.
- \_\_\_\_\_ 9. Ideal secchi disk reading for a productive pond.
- \_\_\_\_\_ 10. These are designed for moving light materials such as sawdust or dried manure.

**Refer to the Answer Key. What is your score?**

## **LEARNING OUTCOME 2**

**Select and operate farm equipment**

## **PERFORMANCE STANDARDS**

- Appropriate farm/fishery equipment and facilities are identified
- Instructional manual of farm/fishery equipment and facilities are carefully read prior to operation
- Pre-operation check-up is conducted in line with manufacturers' manual
- Faults in farm/fishery equipment and facilities are identified and reported in line with aquaculture procedures



## What Do You Already Know?

Let us determine how much you already know about selecting and operating farm equipment. Take this test.

Pretest LO 2

**Directions:** Write **TRUE** if the statement is correct and **FALSE** if it is wrong.

- \_\_\_\_\_ 1. Check the engine oil level on a flat, level surface before using the pump.
- \_\_\_\_\_ 2. You can add fuel in the pump even it is running.
- \_\_\_\_\_ 3. You can operate the pump without water for an extended length of time.
- \_\_\_\_\_ 4. Water pumps are used for testing the concentration of salt water and brine.
- \_\_\_\_\_ 5. Before switching on the pH meter, install the batteries.
- \_\_\_\_\_ 6. Calibration is necessary and should be done regularly.
- \_\_\_\_\_ 7. Remove battery from instruments that you do not plan to use for a month or more.
- \_\_\_\_\_ 8. Avoid repeated or prolonged contact with skin or breathing vapor from water pump.
- \_\_\_\_\_ 9. Never use contaminated gasoline or an oil/gasoline mixture.
- \_\_\_\_\_ 10. Clean the machine and check the condition of its parts.



## What Do You Need To Know?

Read the Information Sheet 2.1 very well then find out how much you can remember and how much you learned by doing Self-check 2.1.

Information Sheet 2.1

### **Farm/Fishery Equipment**

The right choice and proper operation of farm equipment contribute to the successful operation of farm. Farmers/fishermen should familiarize themselves with the uses of different farm tools and equipment and safety measures to be observed in operating a farm.

Keeping new equipment working in prime condition will make your work in the farm more effective and efficient. The easiest way to ensure that your equipment is performing at its best performance is to completely understand its operations and maintenance.

#### **I. GASOLINE POWERED WATER PUMP**

*(Model Nos. GTP50Y, GTP80Y)*

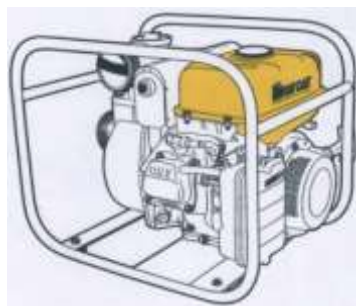

*Gasoline-powered water pump*

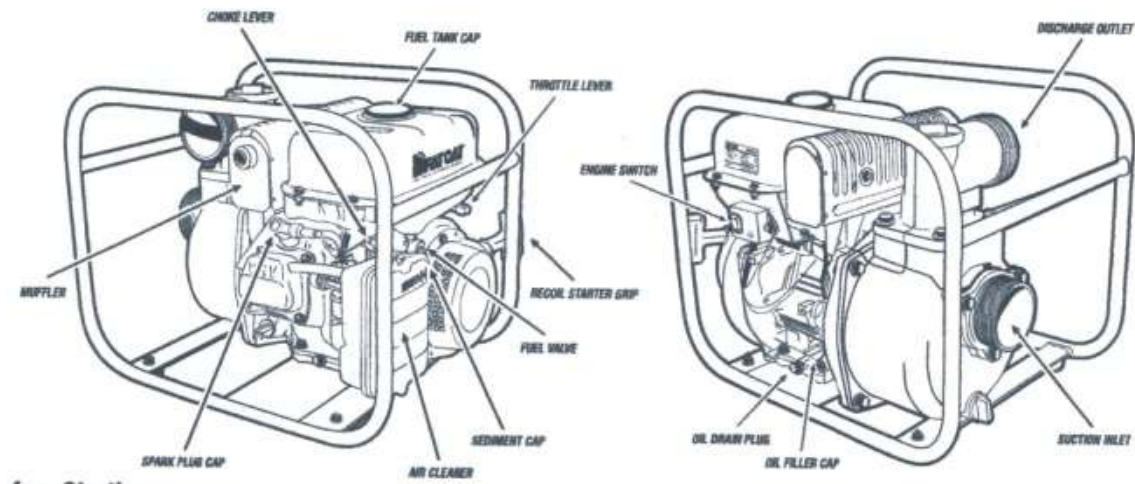

*Parts of Water Pump*

### **A. Before Starting**

#### Engine Oil

The pump has a low oil sensor and will not start or, if running, will halt when the oil level drops to a level that is too low.

1. Check the engine oil level on a flat, level surface before each use of the pump.
2. Fill pump with oil classified as **SE** or **SF** (**SD** if **SE/SF** not available) up to the upper-level mark.
3. Use SAE 10W-30 for general temperature operation.
4. Other viscosities may be used when the average temperature falls within the indicated range.

#### Engine Fuel

***Avoid repeated or prolonged contact with skin or breathing of vapor.*** Do not overfill the fuel tank; make sure to leave an air gap between the fuel and top of the tank to account for fuel expansion. Use unleaded fuel only (with an octane rating of 86 or higher) and ***never use contaminated gasoline or an oil/gasoline mixture!***

#### **WARNING**

Gasoline and its vapors are extremely flammable and can be explosive in certain conditions. Fire or explosion can cause severe burns or death.

1. If the engine has been running, allow it to cool before adding fuel. Refill the tank outdoors.
2. Remove the gas cap slowly to relieve any pressure inside the tank.

3. Keep sparks, flames, heat and other ignition sources away while adding or storing fuel.
4. Do not light a cigarette or smoke when refueling.
5. Wipe up any fuel spills.

### Suction Hose

Must be of a type rated for suction so that it will not collapse when lifting water.

### Hose Connections

1. Insert adapters (included in the package) into one end of the suction hose and discharge hoses (not included in the package), and attach O-rings to the adapters. Hoses have 2 inches (**GTP50Y**) or 3 inches (**GTP80Y**) NPT connections. Use sealant on all threaded connections.

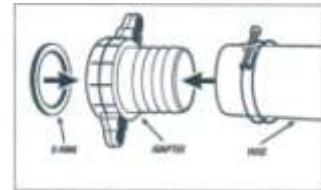

2. Tighten the hose clamp around the discharge hose until the connection is airtight.

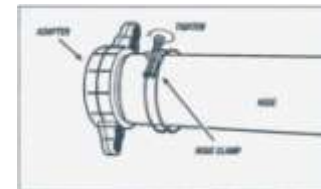

3. Insert a strainer into the suction hose (not included in the package), and tighten the hose clamp around the suction hose until the connection is airtight. Priming will be faster if you install a check valve (foot valve) near the strainer. An air leak may prevent priming and will reduce the output. Make sure the strainer won't quickly become blocked with foreign material, such as small stones or sediment.

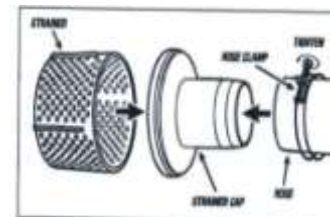

4. Screw the adapters into the appropriate pump fittings. Avoid sharp bends in the hoses, and don't allow heavy objects to compress the hoses.

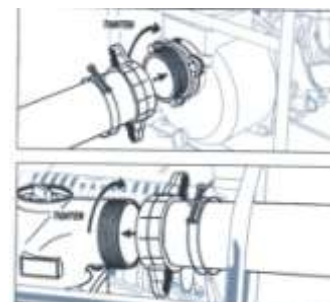



## B. Priming

Remove the upper priming tank plug and fill the tank with water, replacing the plug afterward. Pumps are only self-priming when priming tanks have water and the suction head (lift to the pump) is 20 feet (6 meters) wide or less. The maximum pressure head (lift above the pump) is 80 feet (24 meters) for the GTP50Y or 90 feet (27 meters) for the GTP80Y.

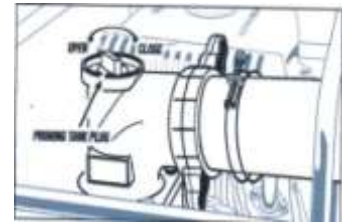

### Operation Guidelines

1. Ensure that the engine has the appropriate liquid to be pumped, and complies with all applicable codes and regulations.
2. When the pump is used for the first time, break in the engine by operating it with the throttle half open (light load) for the first 24 hours before it goes into full speed operation. This will prolong the service life of the engine.
3. Install a check valve in suction lines to prevent liquid fall back when the pump is shut off. It may be necessary to vent the top of the pump in order to blow out air during repriming.

## C. Starting the Engine

1. Place the pump on a level surface.
2. Switch the engine's fuel valve lever to the "on" position.
4. Turn the choke lever to the position shown.
5. Turn the throttle lever slightly to the right.

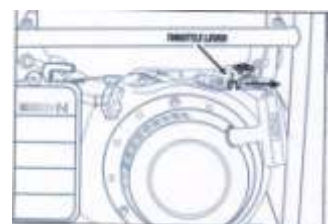

6. Switch "on" the engine.



7. Pull slowly the starter cord until it engages. Then pull hard.



**CAUTION: Do not allow the starter cord to snap back. Return it slowly by hand.**

8. As the engine warms up, return the choke lever to its original position and set the throttle lever in the desired position—move it right to increase engine speed and left to decrease engine speed.



#### **Pump operation guidelines**

1. Clean the machine and check the condition of its parts.
2. Make sure the connections are tight and no fuel is leaking after each use.
3. Save fuel and engine life by reducing engine speed for shallow lifts or small water volumes.

**ATTENTION: Never operate the pump without water for an extended length of time.**

1. After pumping corrosive water, such as seawater, hot spring water or water containing chemicals/pesticides, operate the pump with fresh clean water for three minutes to avoid pump corrosion.
2. In cold weather, completely drain (using the lower priming tank plug) any remaining water inside the pump after each use to prevent damage from formation of ice.

#### **D. High-altitude operation**

The standard carburetor air-fuel mixture will be too rich at high altitude (5,000 feet or 1,500 meters and above), decreasing performance and increasing fuel consumption.

#### **E. Stopping the engine**

Switch off the engine and turn the fuel lever to "off" position.

## F. Transport

1. Make sure the engine switch and fuel lever are in the "off" position.
2. Keep the unit level to prevent fuel spillage. Fuel vapor or spillage may ignite.

### WARNING

**Contact with a hot engine or exhaust system can cause serious burns or fires. Let the engine cool before transporting the unit.**

1. Take care not to drop or strike the pump while transporting.
2. Do not place heavy objects on the pump.
3. Never operate a damaged or defective motor! When adjusting or making repairs to your pump disconnect the spark plug wire from the spark plug and place it away from the spark plug.
4. Do not use a garden hose to clean the pump because water can enter the fuel system and cause problems.

## II. HAND-HELD SALINITY REFRACTOMETER

**Salinity refractometers (REF-211/212)** are designed for testing the concentration of salt water and brine. Its triple scale provides a direct reading of the specific gravity and concentration (parts per thousand) of salt in water and the RHS-10 proves itself valuable for agriculture, food processing and wildlife management. This instrument is equipped with an automatic compensation system, making it ideal for field use.



Style	Model	Range	Min. Div	Accuracy	Remarks
Salinity Refractometers	REF-211	0-10Brix	0.1% Brix	±0.1%	With ATC
	REF-212	0-28Brix	0.2% Brix	±0.2%	With ATC

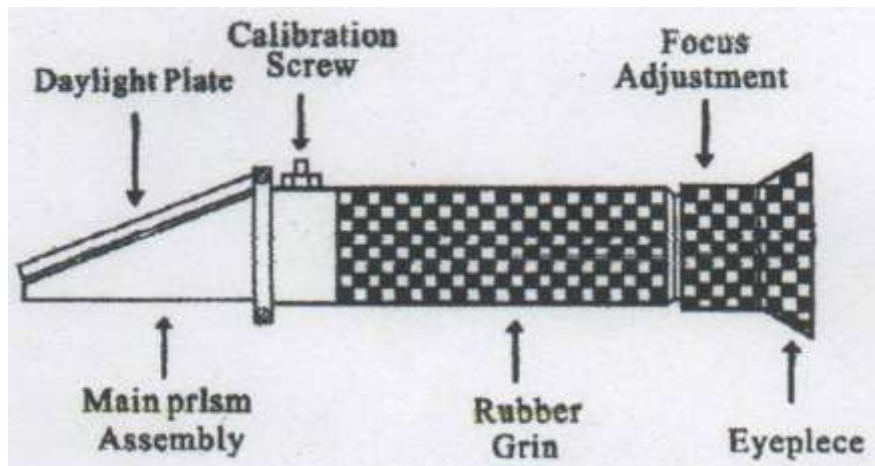

**Parts of a hand held salinity refractometer**

**Operation Steps:**

**Step 1.** Open daylight plate, and place 2-3 drops of distilled water on the main prism. Close the daylight plate so the water spreads across the entire surface of the prism without air bubbles or dry spots. Allow the sample to test on the prism for approximately 30 seconds before proceeding to step #2. (THIS ALLOWS THE SAMPLE TO ADJUST TO THE AMBIENT TEMPERATURE OF THE REFRACTOMETER.)

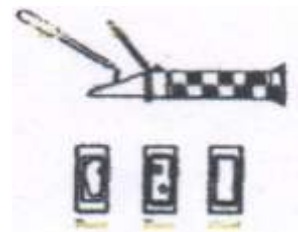

**Step2.** Hold daylight plate in the direction of a light source and look into the eyepiece. You will see a circular field with graduations down the center (you may have to focus the eyepiece to clearly see the graduations). The upper portion of the field should be blue, while the lower portion should be white. (The pictures showed here and showed in step 3 and step 4 serves are only for reference. The right scale is listed in the product.)

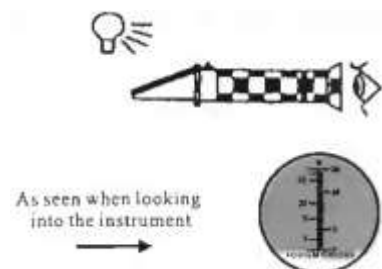

**Step 3.** Using distilled water as a sample, look into the eyepiece and turn the calibration screw until the boundary between the upper blue field and the lower white field meet exactly on the zero scale, such as shown in the picture. Make sure that ambient room temperature is correct for the solution you are using (20°C for our solution that is 68 °F). When working temperature of the room or environment (not the sample) changes by more than 5 of, we recommend recalibrating is recommended to maintain accuracy and reproducibility. If the instrument is equipped with Automatic Temperature Compensation (ATC) system, the ambient working temperature of the room must be 20°C (68 °F) whenever the instrument is recalibrated. Once calibrated, shifts in ambient temperature within the acceptable range (10°C -30 °F) should not affect accuracy.

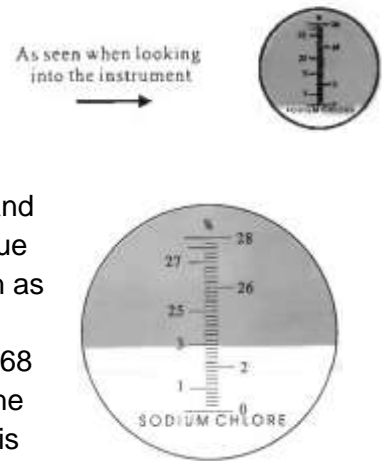

**Step 4.** Do **step 1** using the specimen of liquids that will be measured as the substitute for distilled water. Then do **Step 2** and **Step 3**. When doing **Step 3** again, take the reading where the boundary line of blue and white cross the graduated scale. The scale will provide a direct reading of the concentration.

### III. PEN TYPE PH METER



Pen Type pH meter (www.google.com)

**A. Install battery.** Before power on, be sure to install the batteries.

1. Loosen the battery cover's two screws. (DON'T discard the small washer!)
2. Insert 4 pieces LR44 batteries and make sure polarity is correct.

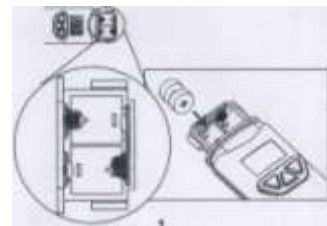

### B. Operation

1. Remove the outer cover and inner caps from the bottom of meter to expose the electrode. The presence of white crystals on the cap or in electrode assembly is normal

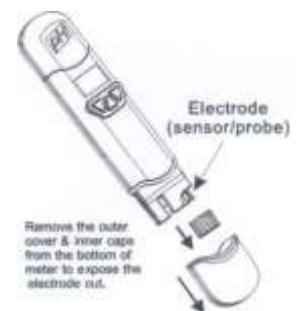

**WARNING:** Please always make sure that the sponge is wet to keep the electrode in good storage condition.

2. Dip the electrode into the test solution. Press "PWR" (power) and stir it to get a stable reading.
3. A small dot (.) will flash while the meter is in measuring mode. In 8681/8682, the screen will not only show pH value but will also display temperature. The temperature unit could be °C or °F.

4. Press the “HLD” (hold) button to freeze current reading. In 8680, the text HOLD will appear on the LCD and no dot “.” will be flashed. Press HLD again to release the hold mode.
5. Turn off the meter by pressing “PWR” button.
6. Cover with the cap to store the pH pen under the temperature 0-50 °C.

### **C. Auto power off (sleep function)**

This meter will shut off automatically in approximately 20 minutes after you stop pressing any key. For operating over longer periods of time, you can disable the sleep mode. Before powering on, press “PWR” and “HLD” keys simultaneously until a “n” appears 1 second on the screen. Then release keys to return to normal mode.

**Note:** The disable sleep mode will be invalid after every power off.

### **D. Automatic Temperature Compensation (ATC): Only for 8681/8682**

8681 and 8682 are capable of measuring Automatic Temperature Compensation (ATC). ATC shows under CAL at the left corner of the screen. To select the temperature unit (°C or °F) preferred, switch off the meter first.

While the meter is off, press PWR and CAL at the same time until °C or °F appears on the LCD. Press HLD to select the preferred unit and then press CAL to save. SA will appear on the LCD for one second and then the screen will go back to normal.

### **E. Calibration Mode (CAL)**

Calibration is necessary and should be done regularly, (recommend everyday if the meter is used often). The unique calibration design of the meter features automatic buffer recognition to avoid errors.

1. Power on the meter.
2. Place the electrode into a buffer solution (4, 7 or 10), pH7 should be calibrated first and then 4 or 10 pH for better accuracy.
3. Press CAL (8681/8682) or CAL (8680) to enter pH calibration mode. The text CA (or CAL only for 8682) will appear on the LCD for 1 second and then text CAL and solution pH value (4, 7 or 10) will be displayed on the LCD.
4. If the buffer is incorrectly inserted or the probe could not detect buffer in below voltage range, the meter will escape calibration mode automatically 10 seconds after. Text En (8680/8681) or End (8682) will appear on the LCD in one second before going back to normal status.
5. If the probe successfully recognizes the buffer, the buffer pH value (4, 7 or 10) will appear on the display in 2 seconds. If the calibration buffer is not 4,7, 10 but another value such as 4.01, just press “HLD” to change the value.
6. The adjustable calibration point range for 4.0 pH is from 3.50 to 4.50, and from 6.50 to 7.50 for 7.0 pH. For 10.0 pH range is from 9.50 to 10.50.

7. When the electrode reads a stable value and you stop pressing any keys, the meter will automatically save the value and then escape the calibration mode.
8. Rinse the probe with de-ionized water or a rinse solution (tap water) after each measurement to make the meter's life last.
9. Repeat above-mentioned steps until the 3 points calibration are finished.

#### **F. Replacing the Battery.**

1. Even if the battery was recently replaced, check its voltage level if you get no response from your instrument.
2. Replace the batteries when:
  - 2.1. The readings on the LCD are flashing (for 8681/86862;
  - 2.2. The battery symbol appears on the LCD (for 8680);
  - 2.3. The meter cannot be powered on.

To replace the battery:

1. Remove the screws from the battery cover.
2. Replace the old batteries with four new button cells (Lr44).
3. Make sure the batteries are in place and the polarity is correct.
4. Put back the battery cover and washers and then screw the cover tightly to make it water resistant.

NOTE: Remove battery from instruments that you do not plan to use for a month or more. Do not leave battery in instrument.

#### **IV. Hand held YSI 55 DO meter**



Hand held TSI 55 DO meter

## A. Preparing the YSI Model 55

There are a few things you must do to prepare your YSI Model 55 for use.

1. Locate the six AA-size alkaline batteries which are included. Use a screwdriver to remove the thumbscrew on the bottom of the instrument. This thumbscrew holds the battery-chamber cover in place. The battery-chamber cover is marked with the words OPEN and CLOSE.

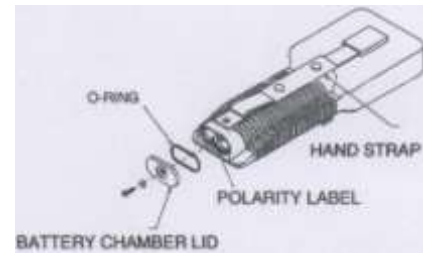

**NOTE:** On some models, the battery cover thumbscrew may be unscrewed by hand (a screwdriver may not be required).

2. There is a small label inside each of the two battery-chamber sleeves. These labels illustrate the correct way to install the batteries into each sleeve of the battery-chamber.

**NOTE:** It is very important that the batteries be installed ONLY as illustrated. The instrument will not function if the batteries are installed incorrectly.

3. Switch the instrument on by pressing and releasing the **ON/OFF** button on the front of the instrument. The instrument will activate all segments of the display for a few seconds, which will be followed by a self test procedure which will last for several more seconds. During this power on self test sequence, the instrument's microprocessor is verifying that the instrument is working. If the instrument were to detect a problem, a continuous error message would be displayed.

**NOTE:** The information on the display will be meaningless since the probe has not yet been prepared.

4. Take the instrument into a dark room and, with the instrument ON, hold down the **LIGHT** key. The instrument's back-light should illuminate the LCD so that the display can be easily read.

## B. Calibration/Storage Chamber

The Model 55 has a convenient calibration/storage chamber built into the instrument's side. This chamber provides an ideal storage area for the probe during transport and extended non-use. If you look into the chamber, you should notice a small round sponge in the





bottom. Carefully put 3 to 6 drops of clean water into the sponge. Turn the instrument over and allow any excess water to drain out of the chamber. The wet sponge creates a 100 per cent water saturated air environment for the probe which is ideal for dissolved oxygen calibration.

### C. Hand strap

The hand strap is designed to allow comfortable operation of the Model 55 with minimum effort. If the hand strap is adjusted correctly, it is unlikely that the instrument will be easily dropped or bumped from your hand.

To adjust the hand strap on the back of the meter, unsnap the leather cover and pull the two Velcro strips apart. Place your hand between the meter and the strap and adjust the strap length so that your hand is snugly held in place. Press the two Velcro strips back together and snap the leather cover back into place.

### D. The meter case

The meter case is sealed at the factory and is not intended to be opened, except by authorized service technicians. **Do not attempt to separate the two halves of the meter case as this may damage the instrument, break the water-proof seal, and void the manufacturer's warranty.**

### E. Preparing the Probe

#### 1. Description

The YSI Model 55 dissolved oxygen probe is a non-detachable, polarographic sensor designed specifically for the YSI Model 55 Handheld Dissolved Oxygen System. Probe cables are available in lengths of 12, 25 or 50 feet.

#### 2. Choosing the right membrane

The YSI Model 5775 standard membrane kit is supplied with the YSI Model 55. This kit contains thirty 1 mil (.001") membranes and a bottle of KCl solution. YSI recommends the 5775 membranes for most applications.

For special conditions, a 0.5 mil (.0005") membrane is available. Order YSI Model 5776 High Sensitivity Membrane Kit. This half-thickness membrane improves measurement time at low temperatures and helps suppress background current at very low dissolved oxygen levels.

When data is routinely collected at sample temperatures below 15°C and at dissolved oxygen levels below 20% air saturation, the low signal current resulting from the use of the standard membranes tends to magnify the probe's inherent constant background signal. Using the high sensitivity membranes in this situation will decrease the percentage of error due to the probe's background current.

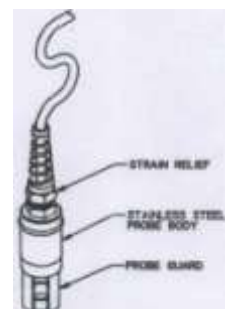

For long-term monitoring situations ONLY, a half-sensitivity, double-thickness, 2 mil (.002") membrane is available. For these applications, order the YSI Model 5685 Membrane Kit that which includes membranes and electrolyte.

### 3. Probe preparation

The YSI Model 55 probe is shipped dry. **Before using the Model 55, the protective membrane on the probe tip must be removed, the probe must be filled with KCl solution and a new membrane must be installed.** Follow the instructions below to install the KCl solution and membrane.

To prepare for installation of a new membrane on your YSI Model 55 dissolved oxygen probe, do the following:

1. Unscrew the probe sensor guard.
2. Remove the old O-ring and membrane.
3. Thoroughly rinse the sensor tip and KCl reservoir with distilled water.
4. Prepare the electrolyte according to the directions on the KCl solution bottle.

### 4. Membrane installation

a. Secure a membrane between your thumb and the probe body. Add electrolyte to the probe until a large meniscus completely covers the gold cathode.

b. With the thumb and forefinger of your other hand, grasp the free end of the membrane.

c. With a continuous motion, stretch the membrane up, over, and down the other side of the sensor, stretching the membrane to the contour of the sensor tip.

d. Secure the end of the membrane under your forefinger while continuing to hold the probe.

e. Roll the O-ring over the end of the probe, be careful not to touch the membrane surface. There should be no wrinkles in the membrane or trapped air bubbles under the membrane. Some wrinkles may be removed by lightly tugging on the edges of the membrane beyond the O-ring.

f. Trim off excess membrane with scissors or a sharp knife. Make sure that the stainless steel temperature sensor is not covered with excess membrane.

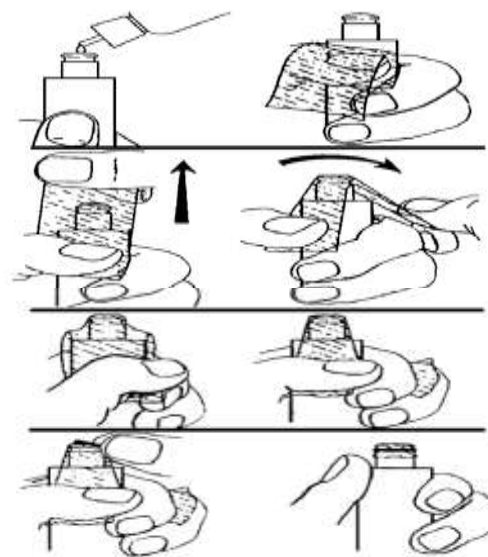

Figure 21

**NOTE:** Handle the membrane material with care, touching it at the ends only.

g. Shake off excess KCl. Rinse the stainless steel thoroughly with distilled water to prevent corrosion. Reinstall the sensor guard. The sensor should be kept in a humid environment (such as the calibration chamber) between measurements and when not in use.

## **5. Probe operation and precautions**

1. Membrane life depends on usage. Membranes will last a long time if installed properly and treated with care. Erratic readings are a result of loose, wrinkled, damaged, or fouled membranes, or from large (more than 1/8 inch in diameter) bubbles in the electrolyte reservoir. If erratic readings or evidence of membrane damage occurs, you should replace the membrane and the KCl solution. The average replacement interval is two to four weeks.
2. If the membrane is coated with oxygen consuming (e.g. bacteria) or oxygen evolving organisms (e.g. algae), erroneous readings may occur.
3. Chlorine, sulfur dioxide, nitric oxide, and nitrous oxide can affect readings by behaving like oxygen at the probe. If you suspect erroneous readings, it may be necessary to determine if these gases are the cause.
4. Avoid any environment which contains substances that may attack the probe materials. Some of these substances are concentrated acids, caustics, and strong solvents. The probe materials that come in contact with the sample include FEP Teflon, acrylic plastic, EPR rubber, stainless steel, epoxy, polyetherimide and the polyurethane cable covering.
5. For correct probe operation, the gold cathode must always be bright. If it is tarnished (which can result from contact with certain gases), or plated with silver (which can result from extended use with a loose or wrinkled membrane), the gold surface must be restored. To restore the cathode, you may either return the instrument to the factory or clean it using the YSI Model 5680 Probe Reconditioning Kit. Never use chemicals or abrasives not supplied with this kit.
6. It is also possible for the silver anode to become contaminated, which will prevent successful calibration. To clean the anode, remove the O-ring and membrane and soak the probe overnight in 3 per cent ammonium hydroxide. Next, rinse the sensor tip and KCl reservoir with deionized water, add new KCl solution, and install a new membrane and O-ring. Turn the instrument on and allow the system to stabilize for at least 30 minutes. If, after several hours, you are still unable to calibrate, return the YSI Model 55 system to an authorized service center for service.
7. If the sensor O-ring is worn or loose, replace it with the appropriate O-ring provided in the YSI Model 5945 O-ring pack.
8. To keep the electrolyte from drying out, store the probe in the calibration/storage chamber with the wet sponge.

## F. Calibration

Dissolved oxygen calibration must be done in an environment with a known oxygen content. Since the amount of oxygen in the atmosphere is known, it makes an excellent environment for calibration (at 100 per cent relative humidity). The calibration/storage chamber contains a moist sponge to create a 100 per cent water saturated air environment.

### 1. Before You Calibrate

Before you calibrate the YSI Model 55, complete the procedures discussed in the *Preparing the Meter* and *Preparing the Probe* chapters of the manual.

To accurately calibrate the YSI Model 55, you will need to know the following information:

- The approximate altitude of the region in which you are located.
- The approximate salinity of the water you will be analyzing. Fresh water has a salinity of approximately zero. Sea water has a salinity of approximately 35 parts per thousand (ppt). If you are not certain what the salinity of the sample water is, use a YSI Model 30 Salinity-Conductivity-Temperature meter to determine it.

### 2. The calibration process

1. Ensure that the sponge inside the instrument's calibration chamber is wet. Insert the probe into the calibration chamber.
2. Turn the instrument on by pressing the **ON/OFF** button on the front of the instrument. Wait for the dissolved oxygen and temperature readings to stabilize (usually 15 minutes after turning the instrument on).
3. To enter the calibration menu, use two fingers to press and release both the **UP ARROW** and **DOWN ARROW** keys at the same time.
4. The LCD will prompt you to enter the local altitude in hundreds of feet. Use the arrow keys to increase or decrease the altitude.

**EXAMPLE:** *Entering the number 12 here indicates 1,200 feet.*

5. When the proper altitude appears on the LCD, press the **ENTER** key. The Model 55 should now display **CAL** in the lower left of the display, the calibration value should be displayed in the lower right of the display and the current DO reading (before calibration) should be on the main display.
6. Make sure that the DO reading (large display) is stable, then press the **ENTER** button. The LCD will prompt you to enter the approximate salinity of the water you are about to analyze. You can enter any number from 0 to 40 parts per thousand (PPT) of salinity. Use the arrow keys to increase or decrease the salinity setting. When the correct salinity appears on the LCD (zero for fresh water), press the **ENTER** key. The instrument will return to normal operation.

Once the calibration process is complete, the only keys which will remain operational are the **MODE** key, the **LIGHT** key and the **ON/OFF** key. You can move back and forth from reading dissolved oxygen in the mg/L mode or the % air saturation mode by pressing the **MODE** key. If you are working in a dark area and having difficulty reading the LCD, press and hold the **LIGHT** key to activate the back-light of the YSI Model 55. The **ON/OFF** key turns the instrument on or off.

**For best results:**

- Each time the Model 55 is turned off, re-calibrate before taking measurements.
- Calibrate at a temperature within  $\pm 10^{\circ}\text{C}$  of the sample temperature.

**V. OTHER AQUACULTURE FACILITIES**

**A. Fishpond** is an artificial body of water surrounded by dikes and with accessories such as gates, pipes and canals to facilitate water supply management.



source: [http://www.spc.int/aquaculture/images/stories/centre/png\\_haqdec2\\_b1.jpg](http://www.spc.int/aquaculture/images/stories/centre/png_haqdec2_b1.jpg)

**B. Fish tank** is a large container of liquids which is rectangular, square or circular in shape. It is usually used in culturing fish.



source:  
[http://www.sardi.sa.gov.au/\\_data/assets/image/0009/46197/fac\\_tankfarm01.jpg](http://www.sardi.sa.gov.au/_data/assets/image/0009/46197/fac_tankfarm01.jpg)

### C. Fish Pen and Cages

**A Fish cage** is a structure fully enclosed by nets on all sides, with the bottom supported either by a fixed rigid frame or by floats that rise and fall with the water level or tide.

**A Fish pen** is an area enclosed by nets on all sides and utilizes the lake bed and other bodies of water as the bottom enclosure.



source: <http://islandtrecker.com/img/ourFishPen.jpg>





## How Much Have You Learned?

### Self-Check 2.1

**Directions:** Sequence the statements according to the procedure of the given farm/fishery equipment. Write the numbers on the blank with 1 representing first statement and then 2, 3 and so on.

#### A. Starting the engine of the water pump.

- \_\_\_ Press the engine switch to "ON" position.
- \_\_\_ Turn the engine's fuel valve lever to the "ON" position.
- \_\_\_ Turn the choke lever.
- \_\_\_ Place the pump on a level surface.
- \_\_\_ As the engine warms up return the choke lever to its original position and set the throttle lever in the desired position—move it right to increase engine speed and left to decrease engine speed.
- \_\_\_ Move the throttle lever slightly to the right.
- \_\_\_ Pull slowly on the starter cord until it engages, then pull hard.

#### B. pH meter

- \_\_\_ Dip the electrode into the test solution. Press "PWR" and stir it to get a stable reading.
- \_\_\_ Press "HLD" button to freeze current reading. In 8680, the text "HOLD" will appear on the LCD and the small dot will not flash. Press "HLD" again to release the hold mode.
- \_\_\_ Remove the outer cover and inner caps from the bottom of meter to expose the electrode out. It is normal if you find white crystals are present on the cap or electrode assembly is normal.
- \_\_\_ Cover with the cap to store the pH pen under the temperature 0-50 °C.
- \_\_\_ A small dot "." is flashing while the meter is in measuring mode. In the 8681/8682, the screen not only shows pH value but also displays temperature. The temperature unit could be °C or °F.
- \_\_\_ Turn off the meter by pressing the "PWR" button.

**Refer to the Answer Key. What is your score?**



## LEARNING OUTCOME 3

### Perform preventive maintenance

## PERFORMANCE STANDARDS

- Tools and equipment are cleaned immediately after use in line with aquaculture procedures.
- Routine check-up and maintenance are performed.
- Tools and equipment are stored in designated areas in line with farm procedures.



## Materials

- Farm/fishery tools and equipment available in the school
- Notebook
- Pencil
- Personal Protective Equipment (PPE)
- Storage room
- Cleaning supplies and materials



## What Do You Already Know?

**Let us determine how much you already know about the preventive maintenance. Take this test.**

### Pretest LO 3

Directions: Write **T** if the statement is correct and **F** if the statement is incorrect.

- \_\_\_ 1. Keep your work unclean. This will help you work more efficiently and safely.
- \_\_\_ 2. It is important to keep engines clean to prevent overheating as well as reduce the dirt that gets into the engine.
- \_\_\_ 3. Read the manual before using new tools and equipment.
- \_\_\_ 4. All workshop equipment should have damage when using.
- \_\_\_ 5. Dispose of liquid and solid waste such as oils, corelant, and worn components in the improper manner.
- \_\_\_ 6. Use the correct tool for the job.
- \_\_\_ 7. Proper tool storage is responsible for many shop accidents.
- \_\_\_ 8. Flush the pump case with clean fresh water, then completely drain it.
- \_\_\_ 9. If an engine appears to use oil excessively, set it aside and do not check the problem.
- \_\_\_ 10. Always use chemical gloves when using any cleaning material because excessive exposure to cleaning chemicals can damage skin.



## What Do You Need To Know?

**Read the Information Sheet 3.1 very well then find out how much you can remember and how much you learned by doing Self-check 3.1.**

Information Sheet 3.1

### Maintenance Program

Maintenance is an excellent means of improving the performance and condition of equipment and facilities. An effective maintenance program identifies problems long before any equipment or facility breaks down or deteriorate, thus providing plenty of lead time for effective maintenance planning.

Factors contributing to the rapidly growing interest in maintenance:

#### *1. Technological development*

This trend leads to a more mechanized and automated equipment, resulting in great productive potential that must be kept working. This means that training facilities are becoming more complicated and require more advanced maintenance.

#### *2. Increasingly expensive raw materials*

Finite raw materials, in combination with a growing population and increasing consumption, inevitably result in higher process for raw material. Consequently, the costs of all by-products rise too. It is therefore cost effective to maintain existing equipment than purchase new ones.

#### *3. Greater complication*

A complicated piece of equipment is composed of many components, any or all of which can be possible sources of trouble. Although the operational reliability of each individual component may be very high, it is necessary to multiply the reliability factor of all components that are dependent on each other in a system, in order to arrive at the total system reliability.

#### *4. Increased fixed costs*

Capital costs constitute a considerable part of the total costs of training and must be covered by the added value created. If training stops as a result of inadequate maintenance, capital costs (depreciation) must still be paid, so the standstill results in a net loss.

#### *5. Reduce delayed activities and eradicate uncompleted work*

Many work processes depend on an uninterrupted flow of activities to produce desired results. If an activity is delayed, the entire work stops. If all the facilities and equipment are reliable and working well, work delay can be reduced

### Gains from maintaining facilities

1. Ensured SAFE environment
2. Improved MORALE of human resources
3. Reduced operational COST
4. Increased PRODUCTION
5. Prolonged LIFE of facilities
6. Prompt DELIVERY of services/product

### Maintenance

The proper use of the training tools and equipment is the first and foremost task in the maintenance. The proper use of tools and equipment is a very important task of the worker. Workers must be able to use them in accordance with instructions in the manufacturer's manuals—this would evidently extend the life of the equipment and tools. When using equipment and simple tools, it is best to read the manufacturer's and/or user's manuals. This would indicate the parts of the equipment, the functions of each part, and the way to maintain it. For immediate reference, the user's manuals must be kept handy and within the Quality Control Area (QCA) where the equipment is kept.

#### **A. How to implement the maintenance program centers on 5 Ms.**

1. Manpower
2. Money (financial resources)
3. Methods and system
4. Machines (facilities)
5. Materials and supplies

**B. Maintenance program** is a comprehensive list of maintenance and its incidents. This would include all maintenance activities to be undertaken, manpower needed, maintenance methods to be used, all the materials and supplies needed for the maintenance and cost involved in the maintenance.

**C. Maintenance schedule** is a list allocating specific maintenance of an area, including equipment and tools to a specific period. The maintenance schedule is just a part of the maintenance program.

### Preventive Maintenance for Farm/Fishery Equipment

#### **I. WATER PUMP**

**A. Engine Oil Change.** Change the oil while the engine is warm for complete and rapid drainings:

1. Stop the engine.
2. Remove the filler cap.



### CAUTION

Used motor oil has been shown to cause skin cancer in certain laboratory animals if repeatedly left in contact with skin for long periods of time. Wash your hands thoroughly with soap and water as soon as possible after handling oil.

3. Open the drain plug and let the oil drain completely into a pan placed under the engine.

4. Check gasket and replace if necessary. Reinstall the drain plug and refill the engine with oil (.16 gallon [.6 liter] capacity).

5. Reinstall the filler cap.

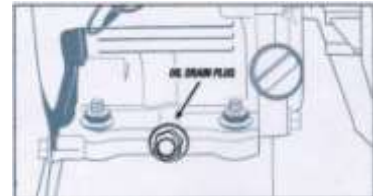

### CAUTION

Please dispose of used motor oil in an environmentally friendly manner. We recommend taking used motor oil to your local service station or recycling center. Do not throw it into the trash or pour it on the ground.

## ***B. Spark plug inspection***

### ATTENTION

The spark plug must be securely tightened. An improperly tightened spark plug can become loose enough to be blown out of the socket.

1. Remove the spark plug.
2. Inspect the spark plug. It should be a tan color. Discard if the insulator is cracked or chipped.
3. Clean the spark plug with a wire brush if it will be reused.
4. Measure the plug gap with a feeler gauge. Make sure the plug gap is between
5. .028 and .031 inch (.7 and .8 millimeter).
6. Thread the spark plug back in by hand to prevent cross-threading, then apply torque to 14 feet-pounds (20 Newton-meter).

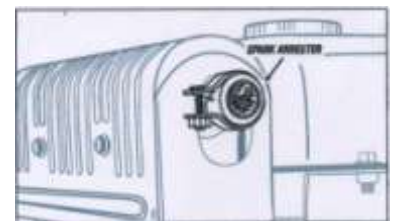

## ***C. Air filter cleaning***

A dirty air filter will restrict air flow to the carburetor. Service the air filter regularly to prevent carburetor malfunction (service more frequently in extremely dusty areas) and excessive fuel consumption.

1. Unscrew the air filter cover.

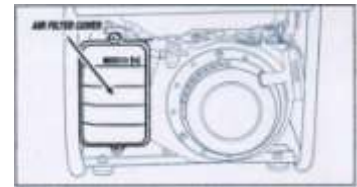

2. Remove the filter element and wash well with an inflammable solvent or soap and water, then dry.



### **WARNING**

Using gasoline or other flammable solvent to clean the filter element can cause a fire or explosion.

### **ATTENTION**

Never run the generator without the air cleaner; this will cause rapid engine wear.

3. Pour a small amount of oil into the filter element and gently squeeze out excess oil. Never wring out the filter element, as it may tear. The engine will smoke if too much oil remains in the filter element.

4. Reinstall the filter element and air filter cover, ensuring the air filter cover seals completely.

### ***D. Fuel sediment cup cleaning***

1. Remove the cup at the bottom of the fuel valve using a small wrench.



2. Clean with a scouring pad and brush. Rinse with water and allow to air dry. Then reinstall.

### ***E. Spark arrester cleaning***

1. Allow the muffler to cool down before cleaning.

2. Remove the screw cap and pull out the spark arrester.

3. Clean the screen with a wire brush and reinstall. Replace the spark arrester if damaged.

### ***F. Miscellaneous***

1. Do not expose the pump's engine to excessive dust, dirt or corrosive vapors.
2. Use a soft bristle brush to loosen caked on dirt or oil.
3. Use low-pressure air (less than 25 pounds per square inch) to blow away dirt.
4. Do not insert any objects through cooling slots. Cooling slots must not become clogged with mud, leaves or any other foreign material.

## **II. HANDHELD SALINITY REFRACTOMETER**

**Note:**

Note shifts in ambient room temperature of the prism prior to measurement. The prism and sample must be at the same temperature for accurate results.

Do the following to maintain handheld salinity refractometer.

1. Do not expose the instrument to damp working conditions and do not immerse the instrument in water. If the instrument becomes foggy, water has entered the body. Call a qualified service technician or contact your dealer.
2. Do not measure abrasive or corrosive chemicals with this instrument. They can damage the prism's coating.
3. Clean the instrument between each measurement using a soft, damp cloth. Failure to clean the prism on a regular basis will lead to inaccurate results and damage to the prism's coating.
4. This is an optical instrument that requires careful handling and storage. Failure to do so can result in damage to the optical components and its basic structure. With care, this instrument will provide years of reliable service.

## **III. PEN TYPE PH METER**

### **A. Maintenance**

1. Keep the pH glass bulb wet by using the cap to protect and store the electrode.
2. Always rinse the pH electrode in de-ionized water or rinse solution (tap water) before next use.
3. Never touch or rub glass bulb for lasting pH electrode life.

## **B. Troubleshooting**

### 1. Power on but no display

- Check that the batteries are in place and make good contact polarity. If needed replace a new battery and try again.

### 2. Slow response

- Clean probe by immersing the electrode in tap water for 10 to 15 minutes, then rinse thoroughly with distilled water or use a general purpose electrode cleaner.

### 3. \_ \_ \_ \_

- Out of pH range, too acidic or too alkaline

### 4. "H." or "L."

- Out of temperature range, too cold or too hot.

### 5. pH value fluctuates quickly

- It is normal when the electrode is not immersed in the water but exposed to air.

## **IV. YSI 55 DO METER**

### **Troubleshooting for YSI 55 DO meter**

**NOTE:**

An error displayed briefly during the first few seconds after turning the instrument on does NOT indicate a problem.

<b>SYMPTOM</b>	<b>POSSIBLE CAUSE</b>	<b>ACTION</b>
1. Instrument will not turn on	A. Low battery voltage B. Batteries installed incorrectly C. Meter requires service	A. Replace batteries B. Check battery polarity C. Return system for service
2. Instrument will not calibrate	A. Membrane is fouled or damaged B. Probe anode is fouled or dark C. Probe cathode is tarnished D. System requires service	A. Replace membrane and KCl B. Clean anode C. Clean cathode D. Return system for service
3. Instrument "locks up"	A. Instrument has received a shock B. Batteries are low or damaged	A. Remove battery lid, wait 15 seconds for reset then replace lid. B. Replace batteries



	C. System requires service	C. Return system for service
4. Instrument readings are inaccurate	A. Calibrate altitude is incorrect B. Salinity setting is incorrect C. Probe not in 100% water saturated air during Calibration procedure D. Membrane fouled or damaged E. Probe anode is fouled or dark F. Probe cathode is tarnished G. System requires service	A. Recalibrate w/correct value B. Recalibrate w/correct value C. Moisten sponge and place in Cal chamber w/ probe and Recal D. Replace membrane E. Clean anode F. Clean cathode G. Return system for service
5. LCD displays "LO BAT" or Main display flashes "OFF"	Batteries are low or damaged	Replace batteries
6. Main display reads "undr"	A. Probe current too low to calibrate B. System requires service	A. Replace membrane and KCl B. Clean anode C. Clean cathode D. Return system for service
7. Main display reads "OVER"	A. Sample O <sub>2</sub> concentration is more than 20 mg/L B. Probe current too high to calibrate C. System requires service	A. Recalibrate using correct altitude and salinity compensation B. Replace membrane and KCl C. Clean cathode D. Clean anode E. Return system for service
8. Main display reads "Er 0"	A. Calibration current out of range B. Instrument's self-test detects improper probe voltage during calibration	A. Replace membrane and KCl B. Clean anode C. Clean cathode D. Return system for service

## V. How to maintain the farm tools and equipment

### A. Cleaning Tool and Equipment

At the end of each working day, clean the tools and equipment you used and check them for any damage. If you note any damage, tag the tool as faulty and organize a repair or replacement. The objective of this procedure is to show how to keep work areas and equipment clean and operational.

### *B. Personal safety*

Whenever you perform a task in the workshop or in farm you must use personal protective clothing and equipment that is appropriate for the task.

1. Work clothing- such as coveralls and steel – (capped footwear)
2. Eye protection – such as safety glasses and face masks.
3. Hand protection – such as rubber gloves and barrier cream

### *C. Safety Check:*

1. Refer to any cleaning agent and follow any recommendations before using it. Some cleaning agents are toxic.
2. Do not use flammable cleaners or water on electrical equipment.
3. Make sure designated walkways are kept clear of any obstructions
4. Always wear protective clothing and appropriate safety equipment.
5. Make sure that you understand and observe all safety procedures when carrying out tasks.

#### *Points to note:*

1. Clean tools and equipment work more efficiently. At the end of each working day clean the tools and equipment you used and check them for any damage. If you note any damage, tag the tool as faulty and organize a repair or replacement.
2. Electrical current can travel over oily or greasy surfaces. Keep electrical power tools free from dust and dirt and make sure they are free of oil and grease.
3. All workshop equipment should have a maintenance schedule. Always complete the tasks described on the schedule at the required time. This will help keep the equipment in safe working condition.
4. Store commonly used tools in an easy-to-reach location. If a tool, or piece of equipment is too difficult to return, it could be left on a workbench or on the floor where it will become a safety hazard
5. Keep your work area tidy. This will help your work more efficiently and safely.
6. Have a waste bin close to your work area and place any waste in it as soon as possible.
7. Dispose of liquid and solid waste such as oils, corelants, and worn components in the correct prescribed manner.
8. When cleaning products lose their effectiveness they need to be replaced. Refer to the suppliers' recommendation for collection or disposal. Do not pour solvents or other chemicals into the sewage system. This is both environmentally hazardous and illegal.
9. Always use chemical gloves when using any cleaning material because excessive exposure to cleaning materials can damage skin.
10. The fumes from cleaning chemicals can be toxic, so wear appropriate respirator and eye protection wherever you are using these products.

#### *D. Step-by-step instruction*

##### **1. Clean hand tools**

- Keep your hand tools in good, clean condition with two sets of rags. One should be lint-free to clean or handle precision instruments or components. The other should be only for preventing rust and corrosion.

##### **2. Clean electric power tools**

- Keep power tools clean by brushing off any dust and wiping off excess oil or grease with a clean rag.
- Inspect any electrical cables for dirt, oil or grease and for any chafing or exposed wires. With drills, inspect the chuck and lubricate it occasionally with machine oil.

NOTE: Improper tool storage is responsible for many shop accidents.

##### **Proper tool storage.**

- Have a specific place for each tool.
- Do not place unguarded cutting tools in a drawer. Many hand injuries are caused by rummaging through drawers that contain a jumbled assortment of sharp-edged tools.
- Store knives or chucks in their scabbards.
- Provide sturdy hooks to hang most tools on.



## How Much Have You Learned?

### Self-Check 3.1

**I. Directions:** Encircle the letter of your choice.

1. What is the most important reason why we maintain our facilities?
  - A. Assures readiness of installed equipment
  - B. Extends the life of facilities
  - C. Improves morale of human resources
  - D. Properly discards hazardous wastes
2. It is a comprehensive list of maintenance and its incidents.
  - A. Housekeeping maintenance
  - B. Maintenance schedule
  - C. Maintenance program
  - D. Maintenance checklist
3. This is the best reference for the proper use and maintenance of equipment.
  - A. Inspection checklist
  - B. Maintenance program
  - C. Maintenance Schedule
  - D. Manufacturer's manuals
4. The 5 Ms in the maintenance program.
  - A. Manpower, management, machines, methods and money
  - B. Manpower, management, materials, machines and money
  - C. Manpower, materials, methods, machines and money
  - D. Manpower, materials, methods, maintenance and money
5. The key factors that contribute to a successful maintenance program.
  - A. Reliability of equipment and facilities
  - B. Maintainability of equipment and facilities
  - C. Documentation
  - D. All of the above

**II.** Write **PP** if the statement tells proper preventive maintenance and **IM** if does not.

- \_\_\_\_ 1. Do not use flammable cleaners or water on electrical equipment.
- \_\_\_\_ 2. Clean the tools and equipment you used and check them for any damage.
- \_\_\_\_ 3. All workshop equipment should have a maintenance schedule.
- \_\_\_\_ 4. Store commonly used tools in a difficult-to-reach location.

- \_\_\_\_ 5. Inspect any electrical cables for dirt, oil or grease and for any chafing or exposed wires.
- \_\_\_\_ 6. Have a waste bin close to your work and place any waste in it.
- \_\_\_\_ 7. Dispose liquid and solid waste such as oils, corelant, and worm components anywhere.
- \_\_\_\_ 8. Keep electrical power tools free from dust and dirt and make sure they are free of oil and grease.
- \_\_\_\_ 9. Keep your work area tidy. This will help your work more efficiently and safely.
- \_\_\_\_ 10. Pour solvents or other chemical when cleaning the equipment.

**Refer to the Answer Key. What is your score?**



## How Do You Apply What You Have Learned?

**Show that you learned something by doing this activity**

### Activity Sheet 3.1

LO1. Select and use farm tools

LO2. Select and use farm equipment

LO3. Perform preventive maintenance.

Instructions:

1. Read the information sheets numbers 1.1, 2.1 and 3.1.
2. For the equipment, read the operation manual of the given equipment and identify its parts.
3. Identify the available farm/fishery tools and equipment in your school.
4. Determine the use of given farm/fishery tools and equipment.
5. Check the condition of given tools and equipment. If so, report the case to the appropriate person before using them.
6. Demonstrate the use of the given farm/fishery tools and equipment. For equipment, the procedure from the operation guide/manual must be followed.
7. Wear the appropriate clothing Personal Protective Equipment (PPE) when demonstrating.
8. Clean the farm/fishery tools and equipment. Perform routine check up and maintenance.
9. Store tools and equipment in appropriate storage places.
10. Follow safety measures while doing the all the activities.



## How Well Did You Perform?

**Find out** by accomplishing the performance criteria checklist honestly and sincerely. Remember it is your learning at stake!

### Performance Criteria Checklist for Activity Sheet 3.1

Have the student/s...	YES	NO	N/A
1. identified the given or available farm/fishery tools and equipment?			
2. read the operation manual of the given equipment including the maintenance procedures?			
3. determined the use of the given farm/fishery tools and equipment?			
4. checked the condition of the given farm/fishery tools and equipment to see if they are in good working condition or bear faults or defects?			
5. reported the condition of the farm/fishery tools and equipment to appropriate person before use?			
6. demonstrated the use of the given farm tools/equipment based on the operation guide/manual?			
7. demonstrated the cleaning procedure of the given farm/fishery tools and equipment based on the operation guide/manual?			
8. undertaken routine check-up and maintenance of farm/fishery tools and equipment?			
9. stored the tools and equipment in its proper location?			
10. worn PPE in doing the activity?			
11. Worked systematically and safely while doing the activity?			

Student's Name \_\_\_\_\_ Date \_\_\_\_\_

Comments/Suggestions:



**Congratulations! You did a great job! Rest and relax a while then move on to the next lesson. Good luck!**

## REFERENCES

### LO1

- Santos C.P. and De Guzman I A. 1999. Technology and Home Economics ABC's of Hand Tools. Their Current Usage and Care.
- Task Force Tech-Voc. 2007. Competency-Based Learning Materials for Aquaculture. Department of Education. Quezon City.

### LO 2

- December 2004. Farm Safety: Standards of Practice for Farms in Nova Scotia: Machinery & Workshop:
- [http://www.aquaticceco.com/pdf/manuals/GTP50Y\\_GTP80Y\\_FatCat\\_Trash\\_Pumps.pdf](http://www.aquaticceco.com/pdf/manuals/GTP50Y_GTP80Y_FatCat_Trash_Pumps.pdf)
- [http://www.omega.com/Green/pdf/RFH\\_Series.pdf](http://www.omega.com/Green/pdf/RFH_Series.pdf)
- [http://www.tequipment.net/pdf/Reed/8681\\_manual.pdf](http://www.tequipment.net/pdf/Reed/8681_manual.pdf)
- <http://www.yisi.com/media/pdfs/055207-YSI-Model-55-Operations-Manual-RevD.pdf>

### LO 3

- Farm: Safety Standards of Practices For Farm Machinery and Workshops (December 2004 )
- Agricultural Mechanics Small Engines – Briggs Straton (Manual)
- [http://www.aquaticceco.com/pdf/manuals/GTP50Y\\_GTP80Y\\_FatCat\\_Trash\\_Pumps.pdf](http://www.aquaticceco.com/pdf/manuals/GTP50Y_GTP80Y_FatCat_Trash_Pumps.pdf)
- [http://www.omega.com/Green/pdf/RFH\\_Series.pdf](http://www.omega.com/Green/pdf/RFH_Series.pdf)
- [http://www.tequipment.net/pdf/Reed/8681\\_manual.pdf](http://www.tequipment.net/pdf/Reed/8681_manual.pdf)
- <http://www.yisi.com/media/pdfs/055207-YSI-Model-55-Operations-Manual-RevD.pdf>



## LESSON 2

### Perform Estimation and Basic Calculation

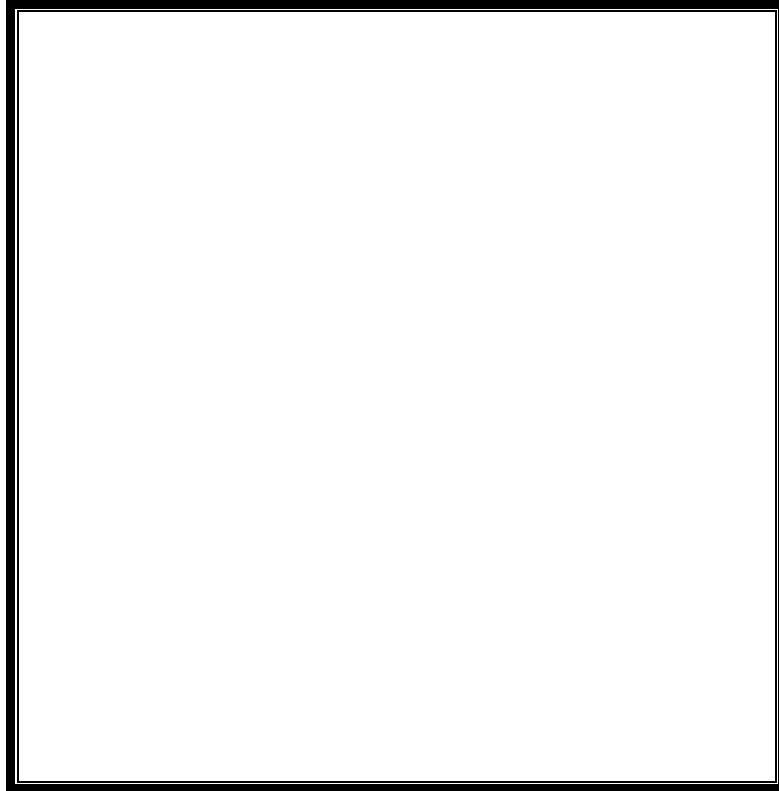

#### **LEARNING OUTCOMES:**

At the end of this Lesson you are expected to do the following:

- LO 1. perform estimation ;
- LO 2. perform basic workplace calculations.



## Definition of Terms

<b>Bill of materials</b>	the list of materials needed that are itemized to complete a job
<b>Calculation</b>	the mathematical determination of the quantity
<b>Conversion</b>	a change in the form of a quantity, a unit, or an expression without a change in the value
<b>Estimation</b>	the process of preparing an approximate computation of the probable cost of a piece of work prepared by a person doing a work
<b>Job requirement</b>	an element necessary to perform a work task in relation to job applicants
<b>Metric system</b>	a system of measurement based on the meter and the gram
<b>Project programming</b>	the listing of activities to determine how and when a project will start and be completed
<b>Unit of measurement</b>	any fixed quantity, amount, distance, etc. used as standard

## LEARNING OUTCOME 1

### Perform Estimation

## PERFORMANCE STANDARDS

- Job requirements are identified from written or oral communications.
- Quantities of materials and resources required to complete a work task are estimated.
- Time needed to complete a work activity is estimated.
- Accurate estimate for work completion is made.
- Estimate of materials and resources is reported to appropriate person



## Materials

- Notebook
- Pencil
- Ruler
- Calculator



## What Do You Already Know?

Let us determine how much you already know about estimation. Take this test.

Pretest LO 1

**Directions: Choose the letter of the correct answer.**

1. Which of the following is the main cause of a project failure?
  - A. low cost of development
  - B. poor planning
  - C. economic considerations
  - D. proper record keeping
2. What is needed to analyze the demands of a particular job in relation to the qualification of a job applicant?
  - A. job requirement
  - B. educational qualification of applicants
  - C. materials needed to complete a work activity
  - D. financial requirements
3. What should be prepared in order to estimate the quality of materials and resources needed to complete a work?
  - A. schedule of development
  - B. bill of materials
  - C. feasibility study
  - D. project proposal
4. What is not included when preparing a bill of materials?
  - A. kind of materials
  - B. quality of materials
  - C. quantity of materials
  - D. cost of materials
5. If the unit cost of one elf load of gravel is Php 1400, how much is the cost of 3 elf loads of gravel?
  - A. Php 2,200
  - B. Php 3,200
  - C. Php 4,200
  - D. Php 5,200
6. How will you estimate the time needed to complete a work activity?
  - A. Hire plenty of laborers
  - B. Prepare a work schedule or program of work
  - C. Make a feasibility study
  - D. Follow a project proposal

7. What is that listing of activities in relation to manpower requirements.
  - A. project estimation
  - B. project development
  - C. project programming
  - D. project proposal making
  
8. The number of days allotted to complete a work activity is dependent on what?
  - A. daily labor requirement
  - B. weekly labor requirement
  - C. monthly labor requirement
  - D. yearly labor requirement
  
9. Which of the following is a function of a project caretaker?
  - A. Prepare a feasibility study
  - B. Form a functional working team
  - C. Secure loan from a bank
  - D. Delegate work to others
  
10. Reporting needed materials for a project to appropriate persons facilitates  
\_\_\_\_\_
  - A. funding of the project
  - B. hiring of needed laborers
  - C. recording of income
  - D. record keeping



## What Do You Need To Know?

Read the Information Sheet 1.1 very well then find out how much you can remember and how much you learned by doing Self-check 1.1.

Information Sheet 1.1

### Performing Estimation

#### **I. Job Requirement**

The worst error a prospective operator can make is to develop an area without project cost estimates and program of development. The disadvantages of this are: waste of development money and difficulty the area. Poor planning is the major cause of project failure which can lead to personal bankruptcy.

Construction of aquaculture facilities involve many procedures and activities, with specific job requirements depending on the type of aquaculture facility that will be established. Each then has its own materials, resources and labor requirements that are the basis of estimating costs and time needed for its construction.

Each type of aquaculture facilities has its own procedures in its establishment. These become the reference to build each type. The job requirements involved in the construction must be addressed. For instance, in constructing fishpond and fish cage, we have the following procedures to follow:

#### **Fish pond construction**

1. Consider the characteristics of pond dikes
2. Compact earthen dikes
3. Prepare the foundations of the dike
4. Calculate dike and excavation volumes
5. Construct dug-out ponds
6. Construct barrage ponds
7. Construct paddy ponds
8. Construct cut-and-fill ponds
9. Protect dikes against erosion by rain
10. Pond-bottom drains
11. First filling of the pond

#### **Fish cage construction**

1. Determining the shape of the cage
2. Preparation of the materials needed for cage construction
3. Constructing the frame of cage

4. Installing the mesh or netting
5. Constructing feeding ring
6. Installing lid to prevent fish from escaping and being preyed on by predators
7. Installing flotation materials (Styrofoam, plastic bottles, PVC pipes) for the cage

## II. Bill of materials & cost estimates

### A. Estimating quantity of materials to complete a work task

In order to estimate the quantities of materials and resources required to complete a work task, there is a need to prepare a bill of materials and cost estimates. Remember that prices of materials change depending on the locality and supply of materials.

**Table1.** Example of bill of materials and cost estimates in constructing a 5 meters X 1.5 meters X 1.0 meter rectangular fish tank

<b>Materials</b>	<b>Quantity</b>	<b>Unit Cost</b>	<b>Total</b>
1. Gravel	1 ELF load	1,400.00	1,400.00
2. Sand	1 ELF load	1,000.00	1,000.00
3. CHB 4" x 8" x 16	160 pieces	5.50	800.00
4. Portland cement	23 bags	182.00	4,186.00
5. Steel Bar (10 mm)	16 pieces	175.00	2,800.00
6. Sahara cement	9 bags	30.00	270.00
7. PVC ¾"	5 pieces	100.00	500.00
8. PVC Elbow ¾"	6 pieces	15.00	90.00
9. PVC 4"	1 piece	220.00	220.00
10. PVC Solvent cement	1 small can	35.00	35.00
11. Faucet	1 piece	130.00	130.00
12. G.I. Wire # 16	1 kilogram	65.00	65.00
13. Hose 5 mm.	10 meters	8.00	80.00,
		<b>Grand Total:</b>	<b>PhP 11,656.00</b>

## B. Estimating Time needed to complete a work activity

Time is a very important element to consider in a work activity. To facilitate completion of a certain job, work schedule or a program of work should be prepared.

**Project programming** is a listing of work activities in relation to manpower requirement versus the volume or piece of required materials at a certain time of development. It is undertaken to determine how and when a project will start and be completed within a given period based on daily output, or by determining the number of days wherein a work will be finished.

The program of work is the basis of the implementation of the project. Each item should be evaluated and calculated realistically so that each job will be properly developed and implemented economically.

**Table 2.** Proposed program of work for one-hectare pond

ACTIVITIES	NATURE OF APPOINTMENT	DAILY LABOR REQUIREMENT (8 hr/day)	DURATION (DAYS)	SUPPORT FACILITIES AND EQUIPMENT
1. Clearing and marking the park of dikes	Daily	5 laborers	14	Plastic hose (1cm. dis. 50 m. long)
2. Earthwork				Digging blades, tractor, rotavator, bulldozer
a. Construction of dikes	Contract labor	20 laborers	45	
b. Construction of dikes	Contract labor	10 laborers	20	
c. Leveling	Contract labor	5 laborers	10	
3. Construction and installation of gates and pipes				Carpentry tools, digging blades, solved:
a. Construction	Daily	5 laborers	10	
b. Installation	Daily	5 laborers	10	
1. Finishing touches	Daily	5 laborers	10	



**Table3. Schedule of development of a one hectare fish pond**

ACTIVITIES	MONTHS				
	JAN	FEB	MAR	APR	MAY
1. Clearing and marking the path of the dike					
2. Earth Work					
a. constructing the dike					
b. constructing the canals					
c. leveling					
3. Constructing gates and installing pipes					
a. construction					
b. installation					
4. Finishing touches					

The fish operator or caretaker acts as overseer of the project showed, and has the following duties:

- Plans ahead what is to be done on time.
- Keeps his co-workers well-informed of the activities to be undertaken.
- Follows the work plan, target and calendar of activities closely to attain its target production.
- Forms a functional working team in order to carry out the plan as schedule.

After all the job requirements are identified, quantity of materials resources and time needed to complete a work activity are estimated. Reporting to appropriate person for funding is necessary (i.e. teacher, project, leader, head teacher, principal, entrepreneurs, and private state holders).



## How Much Have You Learned?

### Self-Check 1.1

#### I. Fill in the blank. Put your answer on the blank provided.

The worst error a prospective operator can make is to develop an area without

1. \_\_\_\_\_ and 2. \_\_\_\_\_.

In order to estimate the qualities of materials and resources required to complete a work task, there is a need to prepare a 3. \_\_\_\_\_ and 4. \_\_\_\_\_.

Prices of materials change depending on the 5. \_\_\_\_\_ and 6. \_\_\_\_\_ of materials.

7. \_\_\_\_\_ is a very important element to consider in a work activity.

To facilitate completion of a certain job, 8. \_\_\_\_\_ or a program of work should be prepared.

9. \_\_\_\_\_ is a listing of work activities in relation to manpower requirement versus the volume or piece of required at a certain time of development

The 10. \_\_\_\_\_ is the basis of the implementation of the project.

#### II. Problem solving.

##### 1. Estimating the quantity of materials and resources needed.

A fish pond requires construction activities. After visitation of the area, the engineer was able to list down some of the materials and resources needed. Below is a table which contains the list and other variables. Compute what is being required in the table:

Materials	Quantity	Unit Cost (Php)	Total (Php)
1. Gravel	2 Elves load	1,400	?
2. Faucet	2 pcs.	?	40
3. Steel Bar	?	5.00	200
4. Sahara cement	?	35	350
5. Portland cement	20 bags	190	?

## 2. Program work of activities

Below is the table of the program of activities which includes the labor and days needed to finish the fish pond construction. Show your computation. Use the formula below for the labor cost.

Activities	Nature of appointment	Daily labor requirements (8 hours/day)	Duration (Days)	Labor cost (P300/day)
1. Clearing and marking the park of dikes	Daily	5 laborers	5	?
2. Earthwork a. Construction of dikes b. Construction of dikes c. Leveling	Contract labor	20 laborers	5	?
3. Construction and installation of gates and pipes	Contract labor	10 laborers	5	?

**Labor cost** = daily labor requirements X duration X 300

**Example: Labor cost for clearing and marking the park of dikes**

**Labor cost** = 5 laborers X 5 days X 300 = \_\_\_\_\_?

Refer to the Answer Key. What is your score?



## How Do You Apply What You Have Learned?

**Show that you learned something by doing this activity.**

Activity Sheet 1.1

### **LO1. Perform Estimation**

#### **ESTIMATING COST FOR THE DEVELOPMENT OF AN AQUACULTURE FACILITY**

Instructions:

1. Read the information sheet 1.1 of this lesson.
2. Each group of student will visit available aquaculture facility (pond, pen, cage, tank, aquarium, etc) in their school.
3. Check the condition of the available aquaculture facility.
4. List down all the required jobs for the development /construction of aquaculture facility.
5. Prepare a program of work and schedule of activities for the development of the given aquaculture facility.
6. Make a bill of materials and cost estimates for the construction/development of the facility.
7. Present your output in class.



## How Well Did You Perform?

**Find out** by accomplishing the Performance Criteria Checklist honestly and sincerely. Remember it is your learning at stake!

### Performance Criteria Checklist for Activity Sheet 1.1

Have the student/s...	YES	NO	NOT APPLICABLE
1. identified the job requirements for the development/construction of the aquaculture facility?			
2. estimated the quantities of materials and resources required to complete a work task			
3. estimated time needed to complete a work activity through a calendar of activities			
4. reported the estimate of materials and resources to appropriate person			

Student's Name \_\_\_\_\_ Date \_\_\_\_\_

Comments/Suggestions:

## LEARNING OUTCOME 2

**Perform basic workplace calculation**

### PERFORMANCE STANDARDS

- Calculations to be made are identified according to job requirements.
- Correct method of calculation is determined.
- Systems and units of measurement to be followed are ascertained.
- Calculations needed to complete work task are performed using the four basic mathematical operations.
- Appropriate operations are used to comply with the instruction.
- Result obtained is reviewed and thoroughly checked.



### Materials

- Calculator
- Pencil
- Notebook
- Meter stick



## What Do You Already Know?

Let us determine how much you already know about basic workplace calculations. Take this test.

### Pretest LO 2

1. The meaning of calculation is;  
A. to ascertain by estimating  
B. to ascertain by computing  
C. to ascertain by visualizing  
D. to ascertain by converting
2. A system of measurement based on meter and gram  
A. Algebraic system  
B. English system  
C. Metric system  
D. Mathematical system
3. If you convert 1 inch to centimeters, multiply 1 inch by;  
A. 30.48  
B. 2.54  
C. 25.4  
D. 28.3
4. The equivalent of 1 metric to kilogram is  
A. 500 kgs  
B. 1000 kgs  
C. 1500 kgs  
D. 2,000 kgs
5. If there are 3.281 feet in 1 meter, how many feet are there in 5 meters?  
A. 16.405  
B. 16.504  
C. 16.054  
D. 16.540



## What Do You Need To Know?

Read the Information Sheet 2.1 very well then find out how much you can remember and how much you learned by doing Self-check 2.1.

Information Sheet 2.1

### Basic Mathematical Operations

#### Work activity in fish culture that needs calculation

##### A. Feed Formulation

Feed formulation is the process of mixing together various ingredients in right proportion to produce a nutritionally balanced diet. The right proportion of ingredients is calculated through the Pearson Square method.

In the example that follows, diet composition is given as g/100g or as %.

##### *Diet with two ingredients*

Balance a 30% protein diet with the following ingredients:

fish meal (60% crude protein)

rice bran (8% crude protein)

#### Use Pearson's Square technique

1. Draw a square and place desired protein level of the diet in the middle.
2. Place the two ingredients and their protein content at the left side of the square.
3. Subtract the protein content of each ingredient from the desired protein level of the feed. Place the difference at the corner of the square diagonally opposite the ingredient. Take absolute value only, that is, ignore positive and negative signs.
4. Take the sum of the numbers at the right of the square.



Fish meal 60%

22 parts

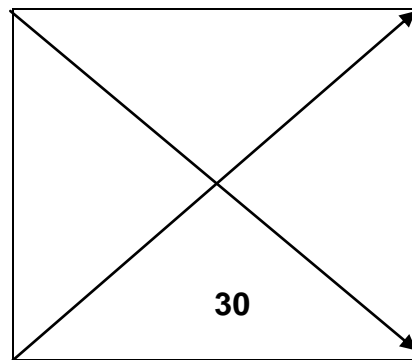

Rice bran 8%

30 parts

52 parts

$$(22 \div 52) \times 100 = 42.31\%$$

$$(30 \div 52) \times 100 = 57.69\%$$

The diet formula is:

Fish meal = 42.31 g

Rice bran = 57.69 g

100.00 gram diet

To check if the desired level of protein was met, multiply the weight by protein content of each feed ingredient and sum up.

$$\text{Fish meal } 42.31 \text{ g} \times 0.60 = 25.39$$

$$\text{Rice bran } 57.69 \text{ g} \times 0.08 = \underline{4.61}$$

30.00 g protein

Therefore, a 100g diet is composed of 30% protein, 57.69g rice bran and 42.31g of the fish meal.

## B. Lime Computation

Liming is a preventive measure or remedial process to increase alkalinity of the ponds and improve aquatic organism survival, optimize growth and ensure desirable water quality. Lime is commonly applied on the pond bottom. To achieve maximum efficiency, lime should be raked and plowed in the soil. Waters that need liming are those that do not turn green when fertilizer is added to the pond water.

*Amount of lime to be used when soil or water is analyzed*

$$\text{Formula : } QL = \frac{DpH - ApH \times 0.5 \text{ tons/ hectare} \times \text{area}}{0.1 \times \text{NVL}}$$

where, QL = quantity of required lime

DpH = desired pH

ApH = actual average pH reading of the pond soil

NVL = neutralizing value of lime

For agriculture lime = 1

For quicklime = 1.73

For hydrated lime = 1.35

A = Area of the pond (in hectare)

Example:

QL (Agricultural lime) =  $DpH - ApH \times 0.5 \text{ tons/ hectare} \times \text{area}$

$$\begin{aligned} QL &= \frac{(6.8 - 6.5) \times 0.5 \text{ tons/ ha} \times 1 \text{ ha}}{0.1 \times 1} \\ &= \frac{0.3 \times 0.5 \text{ tons/ha} \times 1 \text{ ha}}{0.1} \\ &= 3 \times 0.5 \times 1 \\ &= 1.5 \text{ tons agriculture lime} \end{aligned}$$

### **C. Stock Sampling**

Stock sampling is important for estimating average fish weights and standing crop weight. It is also needed to adjust daily feed ration for the fish.

$$\text{Average Body Weight (ABW)} = \frac{\text{total weight at a particular time (g)}}{\text{total number of fish samples}}$$

Example:

Sample	No. of fish	Total weight (grams)
1	30	900
2	40	1200
3	50	1050

Sample 1: ABW =  $\frac{900\text{g}}{30}$  = 30g

30

Sample 2: ABW =  $\frac{1200\text{g}}{40}$  = 30g

40

Sample 3: ABW =  $\frac{1050\text{g}}{50}$  = 21g

50

### Unit of Measurement and Conversion

#### SYSTEM AND UNIT OF MEASUREMENT AND CONVERSIONS USED IN FISH CULTURE

<b>GENERAL CONVERSION TABLE</b>		
<b>To convert</b>	<b>Into</b>	<b>Multiply by</b>
<b>English</b>	<b>Metric unit</b>	
<b>LENGTH</b>		
Inches	Centimeters	2.54
Inches	Millimeters	25.4
Feet	Centimeter	30.48
Feet	Millimeters	304.0
Yard	Meters	0.914
<b>VOLUME</b>		
Pint	Liter	0.473
Quarts	Liter	0.946
Gallons	Liter	3.787

<i>MASS(Weight)</i>		
Ounces	Grams	28.35
Pounds	Kilograms	0.4536
<b>MEASUREMENT CONVERSION TABLE</b>		
<b>To convert</b>	<b>Into</b>	<b>Multiply by</b>
<b>Metric unit</b>	<b>English unit</b>	
Meter	Feet	3.281
Meter	Yard	1.094
Centimeter	Inch	0.394
Millimeter	Inch	0.039

#### OTHER UNITS OF MEASUREMENTS AND CONVERSIONS

<b><u>Length</u></b>	
<b>English units</b>	
1 foot	12 inches
1 yard	3 feet
1 mile	5280 feet
1 nautical mile	1.1516 statute mile
1 acre	208.71 feet
<b>Metric units</b>	
10 millimeter (mm)	1 centimeter (cm.)
10 cm	1 decimeter (dm.)
10 dm	1 meter (m.)
1000 m	1 kilometer (km.)
<b>Equivalents</b>	
1 foot	0.3048 meters
1 statute mi	1.60935 kilometers

1 nautical mi	1.853 kilometers
1 centimeter	0.3937 inches
1 meter	3.28 feet
1 kilometer	3.280.83 feet
<b><u>Volume/capacity</u></b>	
<b>Metric unit</b>	
1 centiliter (cl.)	10 milliliters (ml)
1 deciliter (dl.)	10 centiliters
1 liter (L)	16 deciliters
1 dekaliter (dkl.)	10 liters
1 hectoliter (hl.)	10 dekaliters
1 kiloliter	10 hectoliters
<b><u>Weight</u></b>	
<b>Metric units</b>	
1 centigram (cg)	10 milligram (mg.)
1 decigram (dg.)	10 centigrams
1 gram (g.)	10 decigram
1 dekagram (dkg.)	10 grams
1 hectogram (hg.)	10 dekagrams
1 kilogram (kg)	10 hectogram
1 metric ton	1000 kilograms



## How Much Have You Learned?

### Self-Check 2.1

1. If the total weight of 20 pcs fish samples is 1000g, what is the average body weight of fish?  
A. 20 g                      C. 50 g  
B. 25 g                      D. 60 g
2. What is the equivalent of 1 ton in kilograms?  
A. 10,000 kg                      C. 100 kg  
B. 1,000 kg                      D. 10 kg
3. It is a preventive measure or remedial process that increases alkalinity of the ponds, and improves aquatic organism survival, optimizes growth and ensures desirable water quality.  
A. liming                      C. sampling  
B. feed formulation                      D. computation
4. It is the process of mixing together various ingredients in the right proportions to produce a nutritionally balanced diet.  
A. liming                      C. sampling  
B. feed formulation                      D. computation
5. The neutralizing value of lime (NVL) for agricultural lime.  
A. 1.73                      C. 1  
B. 1.35                      D. 1.5
6. Refers to any fixed quantity, amount, distance, etc. used as standard.  
A. unit of measurement                      C. Computation  
B. unit of competency D. None of these
7. The process of estimating average body weight (ABW) and standing crop weight of fish.  
A. liming                      C. sampling

B. feed formulation                      D. computation

8. How many square meters are there in 1 hectare?

A. 10,000 m<sup>2</sup>                              C. 100 m<sup>2</sup>

B. 1,000 m<sup>2</sup>                                D. 100,000 m<sup>2</sup>

9. How many feet are there in 1 meter?

A. 30.48 ft.                                C. 32.8 ft

B. 3.28 ft.                                 D. 3.048 ft.

10. How many inches are there in 1 foot?

A. 10                                         C. 12

B. 11                                         D. 13

**Refer to the Answer Key. What is your score?**



## How Do You Apply What You Have Learned?

Show that you learned something by doing this activity.

### Activity Sheet 2.1

#### LO2. Perform basic workplace calculation

I. Basic mathematical operations applied in fish culture

Instructions:

Do the following computations and show your solution:

##### A. Feed Formulation:

1. Formulate a fish diet that contains 25% crude protein using fish meal and rice bran with 60% and 8% protein content respectively.
2. Complete the table below.

Ingredients	Inclusion Rate (g)	Analyzed Crude Protein (%)	Calculated Crude Protein (%)
Fish Meal		60	
Rice bran		8	
Total			

##### B. Lime computation

1. Compute the lime needed using the following data:  
Desired pH = 7.0  
Actual pH reading = 6.5  
Pond Area = 1.5 ha
2. Compute the quantity of lime for
  - a. Agricultural lime
  - b. Quicklime
  - c. Hydrated lime



### C. Average body Weight (ABW) of fish samples

1. Compute the average body weight (ABW) of fish using the given data.

<u>Sample</u>	<u>No. of fish</u>	<u>Total weight (g)</u>	<u>Average Body Weight (g)</u>
1	45	1125	_____
2	43	860	_____
3	35	1050	_____
4	55	2750	_____
5	80	3200	_____

## II. Unit of measurement and conversion

Instructions:

1. Identify the available aquaculture facility in your school (pond, pen, cage, tank, aquarium, etc.)
2. Measure the area of the given facility using measuring devices such as meter/meter stick. Obtain data also for volume and weight.
3. Tabulate the data gathered showing the English and Metric System.
4. Show your computation made in converting your measurements.
5. Make a compilation of the output of this activity.

**Performance Criteria Checklist for  
Activity Sheet 2.1**

Have the student/s...	YES	NO	NOT APPLICABLE
1. identified calculations to be made according to job requirements?			
2. ascertained systems and units of measurement to be followed ?			
3. used appropriate operations to comply with the instruction.?			
4. reviewed and thoroughly checked result obtained?			

Student's Name \_\_\_\_\_ Date \_\_\_\_\_

Comments/Suggestions:



**Congratulations! You did a great job! Rest and relax a while then move on to the next lesson. Good luck!**

## REFERENCES

### LO1

- Velasco, R.A. Handbook of construction Estimate
- [http. Lien. Wikipedia.org/wiki/calculation](http://Lien.Wikipedia.org/wiki/calculation)
- CBLM, Fish Culture NC II, Lesson 1, pages 1-9.

### LO 2

- Velasco, R.A. Handbook of Construction Estimate
- [http. Lien. Wikipedia.org/wiki/calculation](http://Lien.Wikipedia.org/wiki/calculation)
- CBLM, Fish Culture NC II, Lesson 2, pages 10-17.

## LESSON 3

### Draw the Layout Plan for Ponds, Tanks, Pens and Cages



#### LEARNING OUTCOMES:

At the end of this Lesson, you are expected to do the following:

- LO 1. draw layout plan for ponds
- LO 2. draw layout plan for tanks
- LO 3. draw layout plan for pens and cages



## Definition of Terms

<b>Anchor</b>	is a heavy object, usually a shaped iron weight with flukes, lowered by a cable or chain to the bottom of a body of water to keep a vessel from drifting.
<b>Blower</b>	a mechanism that increases the draft of air to supply the bellows of an organ.
<b>Brood stock</b>	an adult fish kept in tanks or cages to produce eggs for rearing in the hatchery.
<b>Design</b>	to prepare plans or sketch or model of something to be made.
<b>Fishpond</b>	an artificial body of water surrounded by dikes and with accessories such as gates, pipes and canals to facilitate water supply management.
<b>Fish cage</b>	is a structure fully enclosed by nets on all sides with the bottom supported either by a fix rigid frame or by floats that rise and fall with the water level or tide.
<b>Fish pen</b>	is an area enclosed by nets on all sides and utilizes the lake bed and other bodies of water as the bottom enclosure.
<b>Fouling</b>	is the process by which an object or materials get extremely dirty or impure, disgustingly filthy, or offensive to the senses,
<b>Framework</b>	is a structure, usually rigid, serving to hold the parts of something together or to support something constructed.
<b>Hatchery</b>	a place for the production of fish eggs, larvae and/or fry.
<b>Knot</b>	is a lump made by intertwining the thread, in which one free end is passed through a loop and drawn tightly.
<b>Layout</b>	the manner in which something is displayed or laid out.
<b>Mesh</b>	is the smallest unit of a net.
<b>Mesh size</b>	is the distance between the centers of the opposite knots in the same mesh when it is fully extended at the right angles to the continuing direction of the twines.

<b>Mooring</b>	are the lines, cables, etc. by which water craft or any floating objects or moored or held in place.
<b>Net</b>	is a fabric of thread, cord, rope or twine woven or knotted to form an open pattern or mesh used to catch fish.
<b>Plan</b>	a drawing or diagram made to scale, showing the structure or arrangement of something.
<b>Reservoir</b>	a place where a large quantity of water is collected and stored to have a ready supply of water for use in any eventuality.
<b>Sand Filter</b>	a mechanism or instrument filled with grades of gravel and sand, used to remove particulate matter from the water before it enters the hatchery.
<b>Tank</b>	a large container of liquids—rectangular, square or circular in shape usually used in culturing fish.

## LEARNING OUTCOME 1

**Draw layout plan for ponds**

## PERFORMANCE STANDARDS

- The different compartments of pond are identified.
- Signs and symbols of plan are used according to fishpond engineering standards.
- Lay out of different pond designs are drawn, according to established procedures.



## Materials

- Bond paper
- Pencils
- Ruler



## What Do You Already Know?

**Let us determine how much you already know about layout plan for ponds. Take this test.**

### Pretest LO 1

1. Why are fishpond layouts drawn to scale?
  - a. To lessen labor exerted in the construction.
  - b. To show the layout in a smaller space.
  - c. To show all the compartment units of a fishpond project.
  - d. To display the common accessory units of a fishpond.
2. Which of the following fishpond facilities control the water of the pond system?
  - a. Main gate
  - b. Secondary gate
  - c. Tertiary gate
  - d. All of the above
3. What type of fishpond layout that has one sluice gate and long water supply canal that supplies the different compartment?
  - a. Conventional
  - b. Radiating
  - c. Progressive
  - d. Specialized
4. What fishpond unit is intended for rearing fingerlings to marketable size?
  - a. Transition pond
  - b. Nursery pond
  - c. Rearing pond
  - d. Brood pond
5. Which among the fishpond units is used as water reservoir?
  - a. Head pond
  - b. Catching pond
  - c. Rearing pond
  - d. Transition pond
6. Which is intended for the confinement of breeders?
  - a. Breeding pond
  - b. Rearing pond
  - c. Head pond
  - d. Hatching pond



7. What common accessory unit of a fishpond controls the water in the pond system?
- a. Secondary gate
  - b. Main gate
  - c. Tertiary gate
  - d. Water supply canal
8. In brackish water fishpond, where should fingerlings be acclimatized?
- a. Transition pond
  - b. Rearing pond
  - c. Catching pond
  - d. Nursery pond
9. What is the biggest and highest block of earth that surrounds the entire pond system?
- a. Main dike
  - b. Secondary gate
  - c. Tertiary gate
  - d. Main gate
10. The following are the advantages of pond layout, except.
- a. easy control of pond water
  - b. low productivity
  - c. artificial feeding can be conducted easily
  - d. easy eradication of fish pest and predator.



## What Do You Need To Know?

Read the Information Sheet 1.1 very well then find out how much you can remember and how much you learned by doing Self-check 1.1.

Information Sheet 1.1

### Scaling Procedure

**Scale** - is a series or system of items of increasing or decreasing size, value and etc. It is also the ratio of the distance on the map or drawing and the distance on the ground. Or scale is the distance or measurement in the map or drawing relative to the ground.

*Formula:*

$$\text{Scale} = \frac{\text{Map or drawing distance (meter)}}{\text{Ground distance (meter)}}$$

Example of a scale is 1:10m, 1:100m, 1:1000m, etc.

In the scale, the value of 1 represents the ratio of map (in meter) to the 10m, 100m, or 1000m distance in the ground.

*Problem:*

To determine the ratio of drawing/map 125 meters long and 80 meters wide, use the following formula:

$$\begin{aligned} \frac{1\text{m (map)}}{1,000\text{m (ground)}} &= \frac{X \text{ (map)}}{125\text{m (ground)}} \\ 1,000\text{m } X &= (1\text{m}) (125\text{m}) \\ X &= \frac{125\text{m}^2}{1,000\text{m}} \\ X &= 0.125\text{m or } 12.5\text{cm} \end{aligned}$$

or do the division and multiplication process, thus;

$$\text{a) } \frac{1}{1,000} \times 125\text{m}$$

$$0.01 \times 125\text{m} = 0.125\text{m or } 12.5\text{cm}$$

or, b)  $\frac{1}{1,000} \times 125\text{m} = \frac{125\text{ m}}{1,000} = 0.125\text{m}$  or 12.5 cm

**A map** is a graphical representation of the ground drawn to scale.

**Marginal Information of the map**

1. Sheet Name or Title –the name of the map. This should be placed on top of the map.
2. Sheet Number – this should be placed on the upper right-hand corner of the map.
3. Scale – this should be placed center down of the map.
4. Legend – this should be placed on the lower right-hand corner of the map.
5. Edition Note – This should be placed on the lower left-hand corner of the map.

**Guides in scaling**

1. To determine the measurement of every line in the drawing, every dimension or linear measurement in the ground surface or field should be divided by the given scale.

Ex. Given scale is 1:1000m

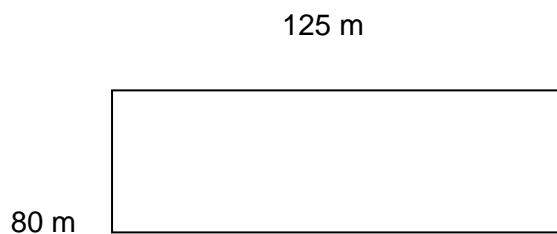

Solution:

$$\frac{125\text{ m}}{1,000\text{m}} = 0.125\text{m}$$
 or 12.5cm

2. If scale is changed to a bigger value, the drawing or figure of the same dimensions of a lot becomes smaller.

Ex. 1:1000m is changed to 1:2000m

Solution:

$$\frac{125\text{m}}{2,000\text{m}} = 0.0625\text{m}$$
 or 6.25cm

3. If scale is changed to a smaller value from the original (very first) scale, the drawing or figure of the original dimensions of a lot becomes larger.

Ex. 1:1000m is changed to 1:100m

Solution:

$$\frac{125\text{m}}{100\text{ m}} = 1.25\text{m or } 125\text{cm}$$

4. If you want to check the correctness of the work, multiply the line measurement in the drawing (in cm) by the given scale (also in cm) divide by 100cm/m to determine the linear measurement in the ground surface.

Ex. Scale is 1:1000m

Solution:

$$12.5\text{cm (in the drawing)} \times 1000 \text{ scale} = 12,500\text{cm or } 125\text{m}$$

Or

$$\frac{12.5\text{ cm} \times 1000}{100\text{ cm/m}} = \frac{12,500\text{ cm}}{100\text{ cm/m}} = 125\text{ m}$$

### **Fishpond layout and design**

**Fishpond** is an artificial body of water surrounded by dikes and with accessories such as gates, pipes and canals to facilitate water supply management.

In view of the high cost of fishpond development, the layout of improved types of fishponds, and the specifications for different pond designs must be simple and functional. The nature of compartments or units of a fishpond project is dependent upon the nature and quality of water supply and the species of fish to be cultivated.

#### **Fishpond layout**

A one-hectare layout of a conventional pond system with the following specifications:

Area = 10,000 m<sup>2</sup>

NP = 1% of the total production area

TP = 9% of the production area

RP = 80% of the production area

CP = At least 2% of the NP

$$\begin{aligned} \text{NP} &= 10,000 \times 1\% \\ &= 10,000 \times 0.01 \\ &= 100 \text{ m}^2 \end{aligned}$$

$$\begin{aligned} \text{RP} &= 10,000 \times 80\% \\ &= 10,000 \times 0.80 \\ &= 8,000 \text{ m}^2 \end{aligned}$$

$$\begin{aligned} \text{CP} &= 100 \times 2\% \\ &= 100 \times 0.02 \\ &= 2 \text{ m}^2 \end{aligned}$$

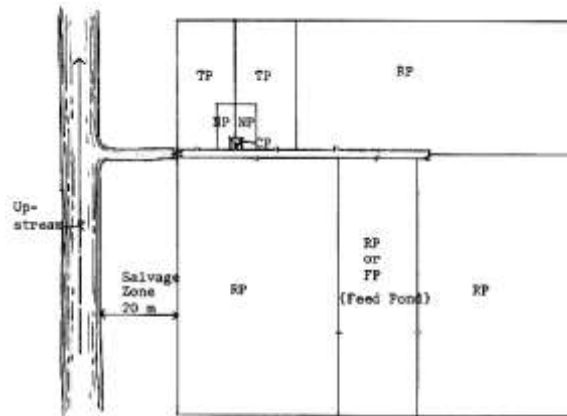

After the proposed fishpond site is thoroughly examined and selected based on the required factors for pond selection, consider the following compartment units and common accessories of the pond system in making the layout plan.

### Common Units of a Fishpond



Transition pond



Rearing pond



Catching pond



Water supply canal

1. **Nursery pond (NP)** – for the rearing of fish fry fingerlings. The most suitable place is an area that can be easily supplied with fresh, unpolluted water all the time and at an elevation where it can be readily drained even during ordinary low tide. The size of the NP depends primarily on the fingerling requirements of the rearing ponds based on the maximum yearly targeted production.
2. **Transition pond (TP)** - for the storage or acclimatization of fingerlings. It is located adjacent to the nursery pond for effective and easy transfer of fry. Its pond bottom is a little bit lower than that of the nursery pond.
3. **Rearing pond (RP)** – for raising fingerlings up to marketable size. It is the largest compartment in the pond system.
4. **Breeding pond** – for confining breeders.
5. **Hatching pond** – for depositing eggs until these are hatched.
6. **Catching pond (CP)** – for confining and catching fry, fingerlings and fish of marketable size. The gate area is constructed inside the pond where it is intended to be used.
7. **Head pond** – for storing reserve water.
8. **Feed pond** – for producing food such as lab-lab, lumut or plankton. In fishpond areas where natural foods not grow well and supplementary feeding is necessary, one of the RP's or NP's could be utilized as a feed pond. It should be a separate compartment ideally located near the pond where supplementary feeding is intended.
9. **Water supply canal** – for supplying water to the different compartments.

### Types of improved freshwater fishponds layout

1. Conventional – consist of one sluice gate and long water supply canal. This supplies the different compartments.

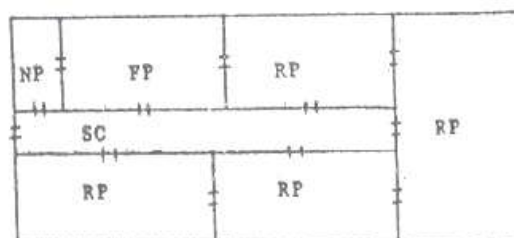

2. Radiating – has one sluice gate; wide and short supply canal; and secondary gates in the different compartments.

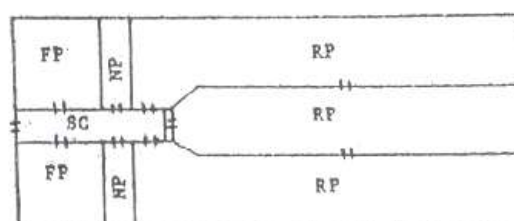

3. Progressive – consists of one sluice gate; long supply canal and a secondary gates provided to different compartments of progressively increasing areas.

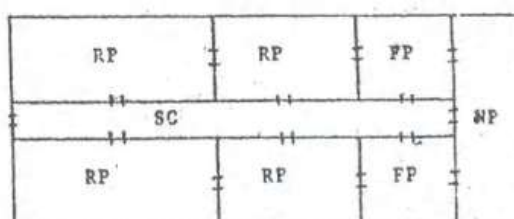

- Specialized – has one sluice gate; one or two drainage gates. Two secondary gates compartment; and a large supply and catching canal/pond.

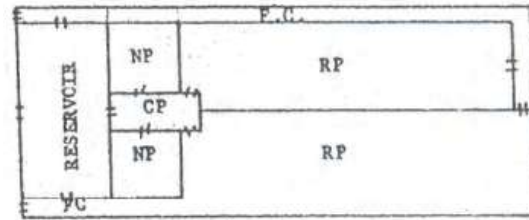

### Advantages of the improved types of layout

- Easy control of pond water.
- Easy eradication of fish pest and predator.
- Easy means of cropping.
- Pond bottom cultivation can be done when desired.
- Artificial feeding can be conducted easily when resorted to after the natural food of fish has been consumed.
- High productivity.

### Lay-out specifications for brackish water fishpond systems

A. **Conventional pond system** - The NP comprises about 1% of the total production area (TPA). The TP comprises about 9% of the TPA. The RP comprises about 80% of the TPA. The CP intended for a NP and TP must be at least 2% of the compartment's watered area and 1 to 1½ if it is intended for the RP.

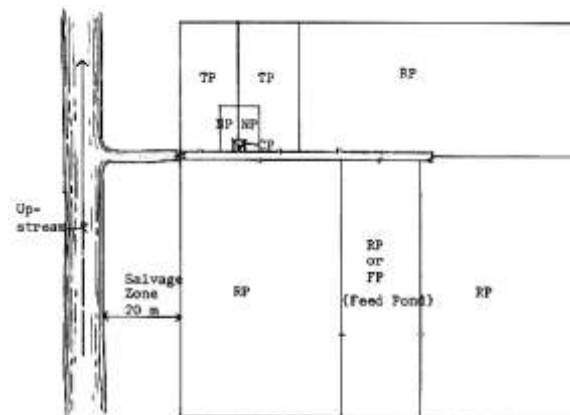

Conventional pond system

B. **Modular Pond System.** The NP comprises about 4% of the TPA. The TP covers only 6% of the TPA. The RP is divided into three Production Process Sates (PPS). The main idea is to transfer the fingerlings to the next larger module. The ratio of the area of the three stages of PPS is 1:2:4 for upper PPS and 1:3:9 for lower PPS.

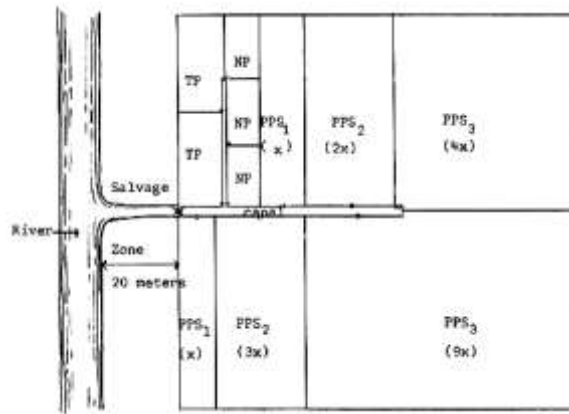

Modular Pond System

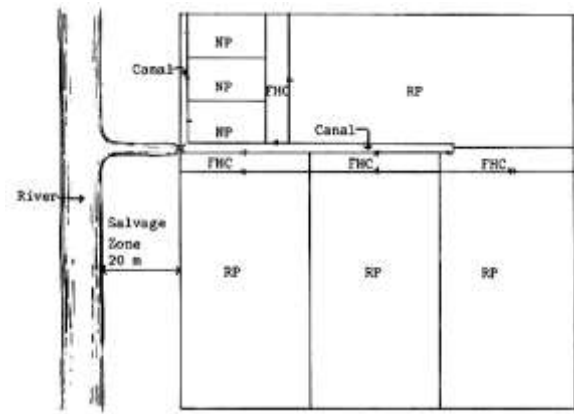

Multiple stock/harvest system

**C. Multiple Stock/Harvest system.** There will be at least two (2) NP's comprising six percent of the total production area. A fish holding canal (FHC), which holds fingerlings when the rearing ponds are being prepared, covers at least 1% of each RP's area. It is connected to the RP in such a way that each RP will have a separate FHC. The RP covers up to 94% of the TPA including FHC. The general practice is to stock at different times, different size, and group of fingerlings and harvests the bigger one's selectively with the use of the gill net.

### Lay-out Specifications for freshwater fishpond systems

**A. Barrage pond type** – a pond type usually filled by rainfall or by spring water. A series of ponds in this type require drainage pipes and overflow ditch.

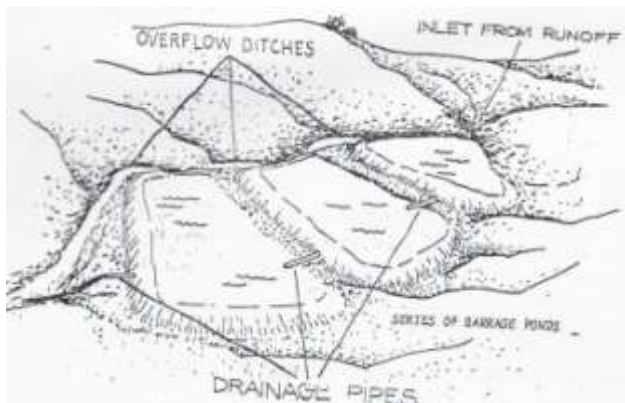

**B. Diversion pond type** – a pond type which has a diversion canal to serve as a passageway of water from the main water body, e.g. creek, brook and the like.



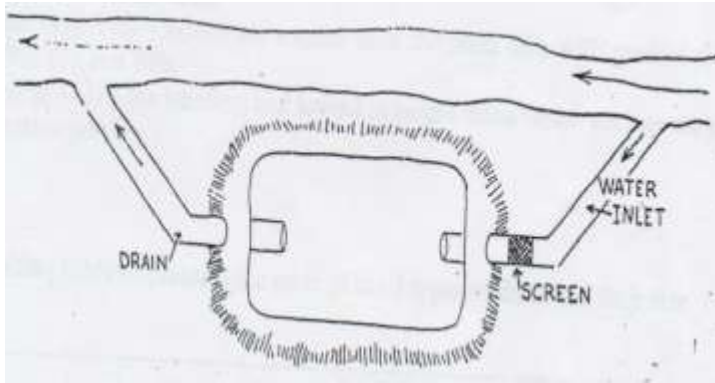

### Two types of layout of a diversion pond

1. **Rosary type** – a type in which series of ponds are built one after another in a string. In this type of layout, all ponds drain into each other; upper pond drains to the lower pond.

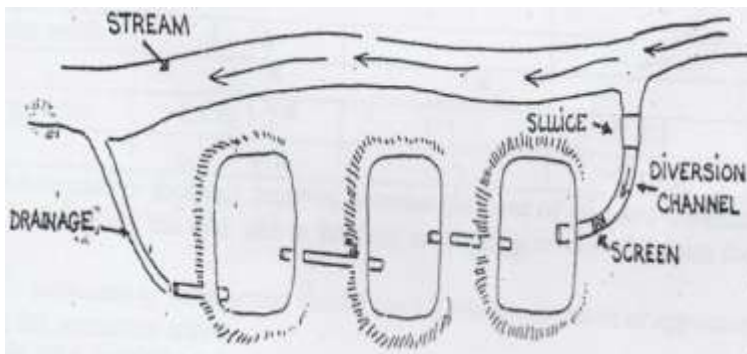

2. **Parallel type** – a type in which ponds are built parallel to each other and each pond of which has an inlet and an outlet.

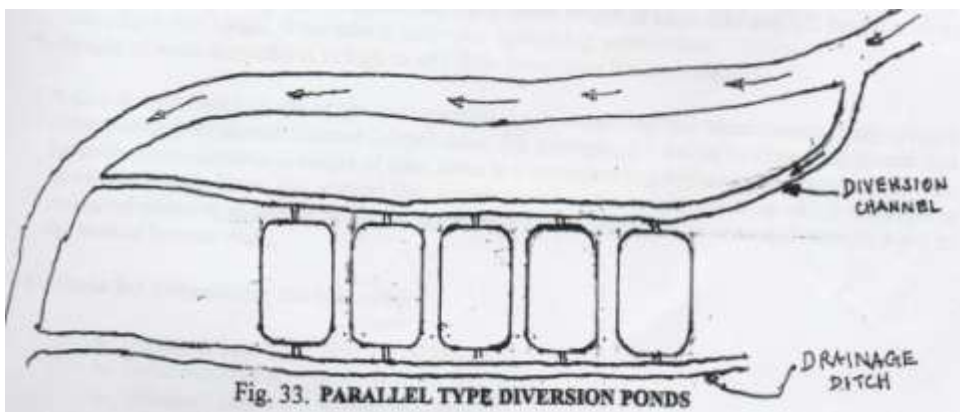

### Advantages and disadvantages

#### a. Barrage ponds vs. diversion ponds

- diversion ponds are less likely to overflow and its water source is often more dependable throughout the year than with barrage ponds.
- barrage ponds require less construction and are likely to be cheaper.

### ***b. Rosary types vs. parallel types of diversion ponds***

- a parallel diversion ponds are better in terms of water management

since each pond compartment can be operated or worked out independently without involving the other ponds.

- on the other hand, rosary types are cheaper and easier to build.

## **Pond water control structures**

### **A. DIKES**

#### *Types of dikes*

a. Primary, main or perimeter dike

- it is the dike that encloses and protects the entire pond system.

- it is the tallest and widest among the types of dikes with the most gradual slope.

- it is the dike that should be provided with a freeboard of 0.3–1 meter after shrinkage and settlement.

- the dike that is usually provided puddle trench measuring 30 centimeters in width and 50 centimeters in height dug up along the central path of such a dike.

*Freeboard* – is the additional height of a structure, e.g. main dike. It is above high water level to prevent overflow.

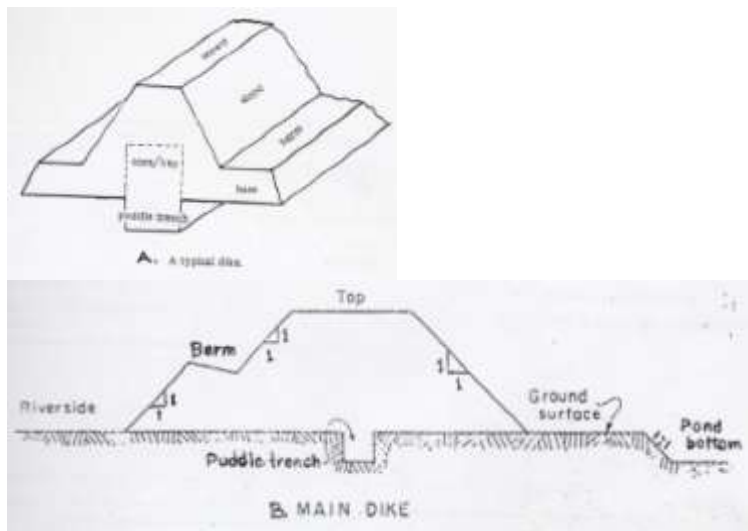

b. Partition dike

Two classifications of partition dikes

b.1. Secondary dike – which are smaller than the main dike with gradual slopes. These enclose NPs, TPs, and RPs.



b.2. Tertiary dike – the smallest and lowest in height dikes that enclose the catching ponds and fry acclimation pond.



### Parts of dikes

The following table presents the parts of the 3 types of dikes and their size specifications.

Parts	SIZE (meter)		
	Main dike	Secondary dike	Tertiary dike
• Crown or top width	2 – 4 <sup>b/</sup>	1 – 2	<1
• Base or bottom width	4 – 10	3 – 7	1.3 - 2
• Height	_____ <sup>c/</sup>	_____ <sup>e/</sup>	_____
• Height to slope ratio	1:1 to 1:2 <sup>d/</sup>	1:1	≤ 1:1
• Berm	0.5 – 0.6	0.5	< 0.5

<sup>a/</sup>Berm is a narrow path or footwalk reserved between the base of the dike and the excavated pond. It also serves in fortifying the dike and in holding or trapping eroded soil from the dike top and wall.

<sup>b/</sup>Perimeter dike subjected to wave action should have a crown with a minimum value of approximately equal to the height of the maximum wave.

<sup>c/</sup>Height of main dike should be 0.3–1 meter higher than the highest water level in the site.

<sup>d/</sup>A slope of 1:1 for clay soil is appropriate for a 3-meter height of main dike and 1:2 height to slope ratio for > 4 m height, if the dike is subjected against big wave action.

<sup>e/</sup>The height of secondary dike is as high as or a little lower than the main dike.

A **dike** is built based on the height to slope ratio, i.e. a certain vertical measurement (height) has a corresponding horizontal distance (slope) ratio. For

example, a 1:1 height to slope ratio means that for every meter increase in height of dike, there is a corresponding horizontal measurement of 1 m. In calculating the slope, the vertical line, which serves as the height and from which the slope is measured outward, should be projected at the edge of the crown and be extended straight down to the base or bottom.

**Formula for determining the following:**

- a. Unknown base:  $B = [2 (H)(S)] + C$
- b. Unknown crown:  $C = B - [2(H)(S)]$
- c. Unknown Slope:  $B - C = 2 (H)(S)$   
 $S = \frac{B - C}{2H}$

$$2H$$

The dike should be provided with a freeboard after shrinkage and settlement of 0.3 to 1 meter above the higher water level. Given below are the recommended allowance for shrinkage and settlement.

Condition	Allowance for structure and settlement (%)
1. Poor material and poor methods and practices in construction	1.5 – 3.0
2. Soil exceptionally high in organic matter	4.0 or more
3. Compacted by construction equipment	5 – 10

The total height of the main dike above the ground level can be computed by the following formula:

$$H_m = \frac{(H_{at} - G_s) + M_f + F}{1 - \frac{(\%S)}{100}}$$

- Where:  $H_m$  = height of the main dike
- $H_{at}$  = highest astronomical tide
- $G_s$  = elevation of the ground surface
- $M_f$  = maximum flood level
- $F$  = allowance for freeboard
- $\%S$  = a percent shrinkage and settlement

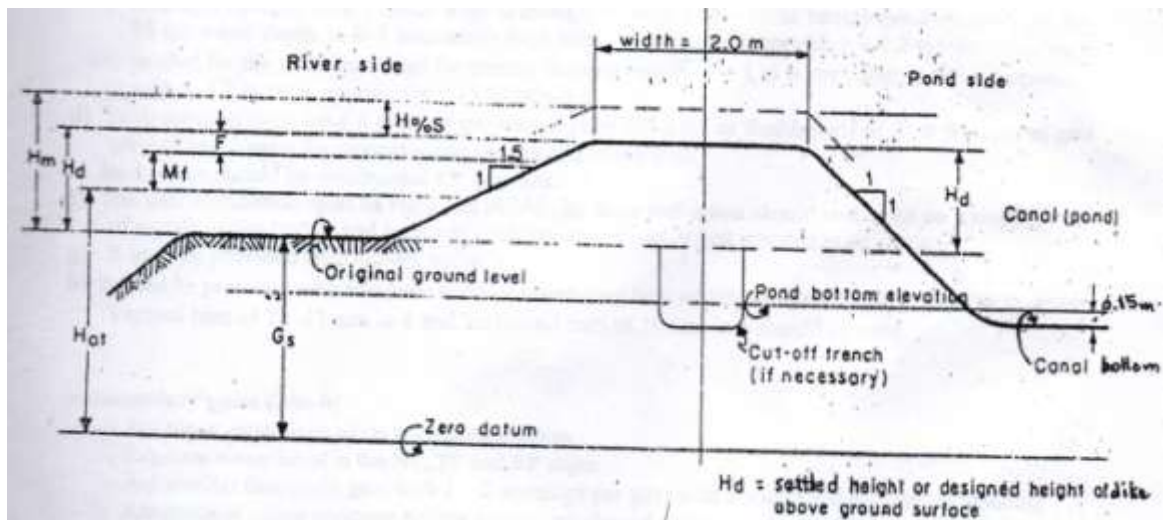

Cross-section of perimeter (main) dike and basis for determining height

d. Unknown height:  $B - C = 2 (H)(S)$   
 $H = \frac{B - C}{2S}$

e. Area of dike:  $A_d = \frac{(B + C) H}{2}$

- Where:
- B = base
  - C = crown
  - H = height
  - S = slope
  - 2 = constant number
  - $A_d$  = area of dike

## **B. GATES**

### ***Types of gates:***

#### ***a. Primary or main gate/s (Fig.35 a-d)***

- is/are the pond gate/s constructed on the perimeter dike/s.
- is/are the largest and tallest gate/s depending the size of the entire pond system.
- links the pond system to the source of water.
- regulates the exchange of water between the pond system and the tidal stream.

- it is usually situated at the central side of a main dike, facing the source of water.

#### **Requirements in the design of main gate:**

1. It should be as high as the main dike.
2. Its floor elevation should be lower than the lowest pond bottom elevation and as low as or slightly lower than extreme low tide.
3. It may have 1-4 openings as waterway depending upon the size of the entire pond system to be flooded.
  - a. A single opening that is 1 meter wide is enough to flood a 10-15 hectare bangus pond system with 50-75 cm water depth in 2-3 successive high tides. A 2-3 openings with 1-1.2 m each opening is needed for the same hectareage for shrimp farming requiring  $\geq 1$ m water depth, and 3-4 openings with 1-1.2 m each opening for  $>15$  ha of pond.
4. Each opening must have 4 pairs of grooves: 2 pairs for slabs or flashboards to fit at the central gate portion and 2 pairs for screens – one at each end of the gate.
5. Its 4 wings should be constructed  $45^\circ$  outward.
6. The gate foundation must be rigid and stable. Its floor and apron should rest or sit on a combination of wooden piles (tulus) and layers of boulders and gravel or just wooden piles alone.
7. It must be provided with cut-off walls.
8. It must be provided with adequate reinforcement steel bars which are spaced  $\leq 40$  cm center to center. Vertical bars of 12-13 mm in  $\varnothing$  and horizontal bars of 10mm in  $\varnothing$  should be used.

#### *b. Secondary gates (Fig. 36 a-b)*

- are those gates situated on the partition dikes.
- regulates water level in the NP, TP and RP units.
- are smaller than main gate with 1-2 openings per gate with a width of 0.8 – 1 meter per opening.
- are made of either concrete hollow blocks, reinforced concrete mix, or wood.

#### *c. Tertiary gates*

- are those gates installed in the catching ponds.
- are the smallest gates with opening width of 0.5 – 0.8 m

#### Classification of gates:

1. Sluice gates (Fig. 35 a-c)
  - are those pond gates constructed to be open on top (not concealed) across the dikes with 2 pairs of grooves provided at the central portion of the sidewalls for fitting the slabs and another 2 pairs for screens at each of the gate ends.

- are easy to maintain and allow rapid water discharge rates.
- may not render passage of vehicular transport.

2. Monk gates (Fig. 37 a-c)

- gates whose central bodies are concealed in the dikes (the top of the main parts of the gate is covered with soil, which allows motor vehicles to pass over).

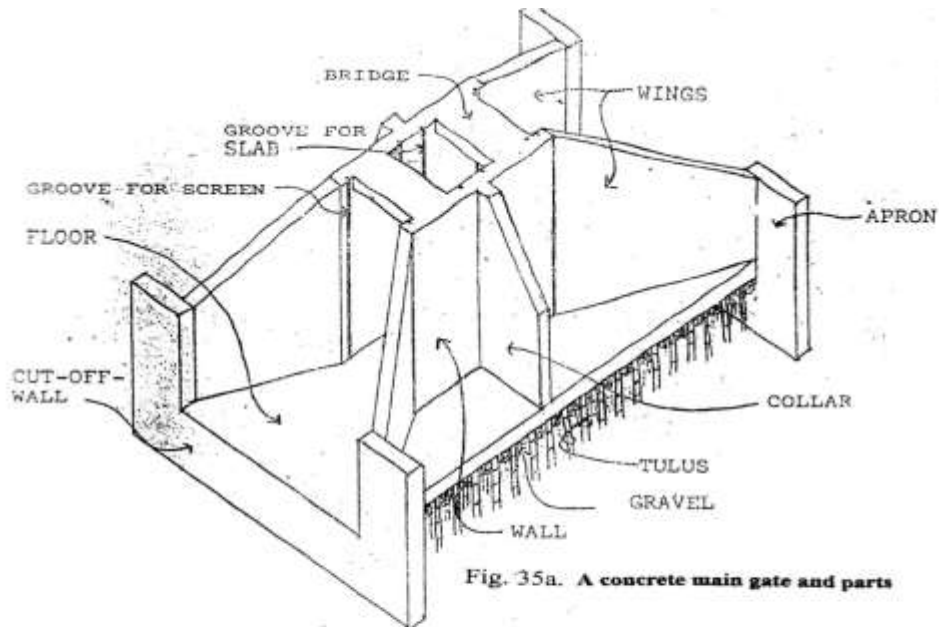

Fig. 35a. A concrete main gate and parts

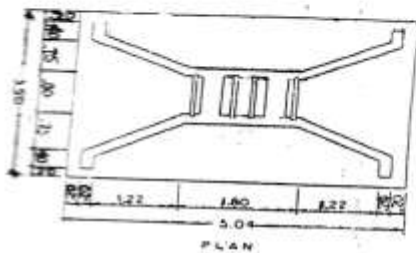

Fig. 35b. Main concrete gate single-opening (After Lijaseco, 1977)

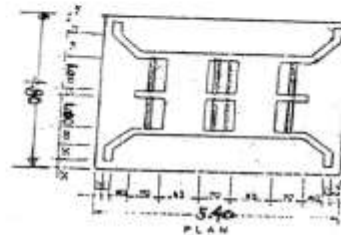
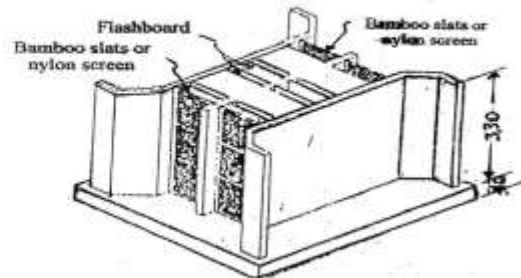
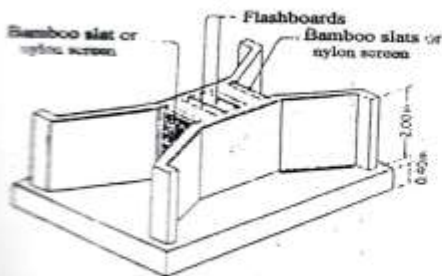

Fig. 35c. Main concrete gate double-opening (After Lijaseco, 1977)



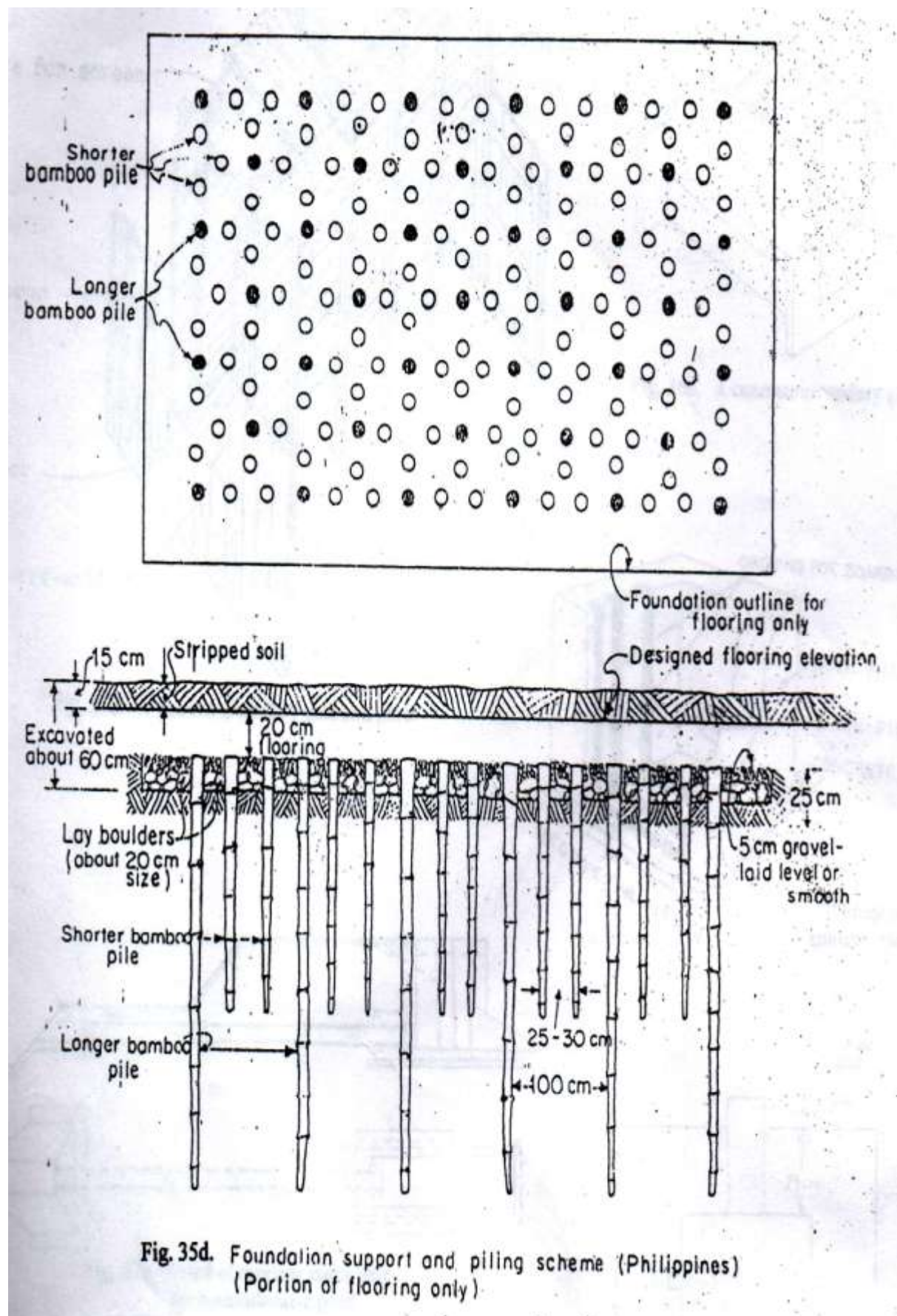

Fig. 35d. Foundation support and piling scheme (Philippines)  
(Portion of flooring only)



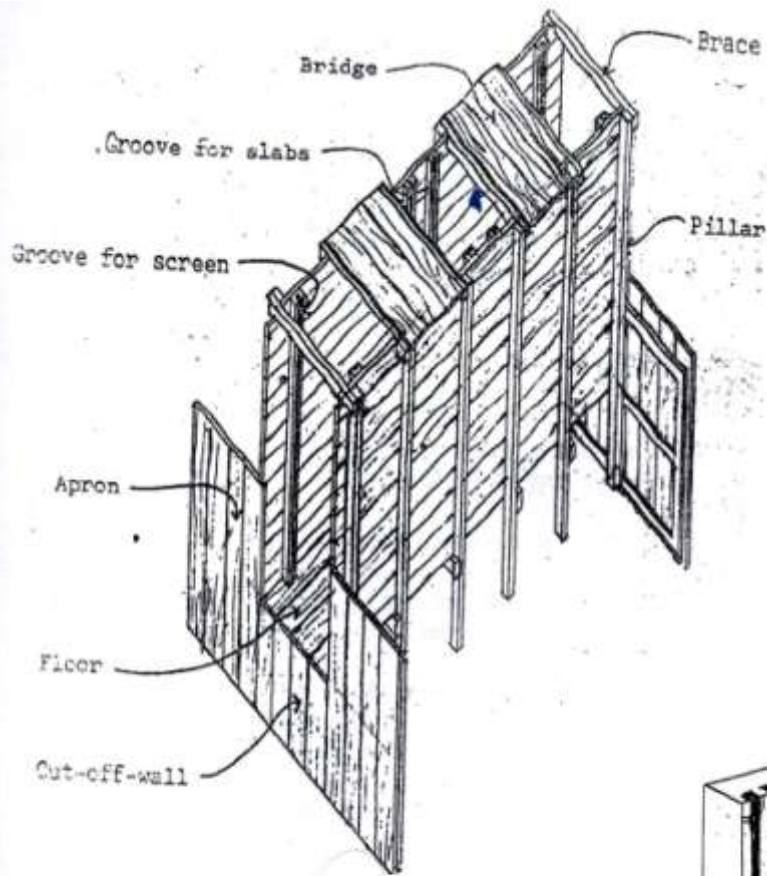

Fig. 36a. A wooden secondary gate and parts

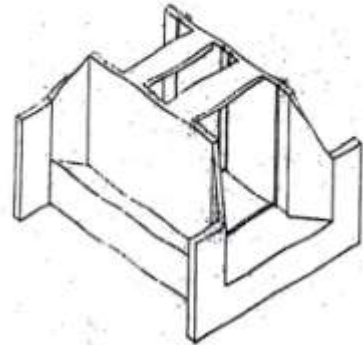

Fig. 36b. A concrete secondary gate

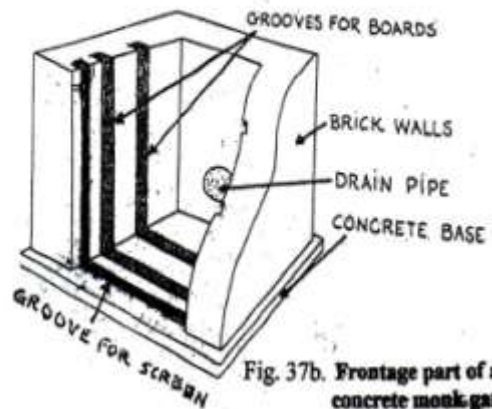

Fig. 37b. Frontage part of a concrete monk gate

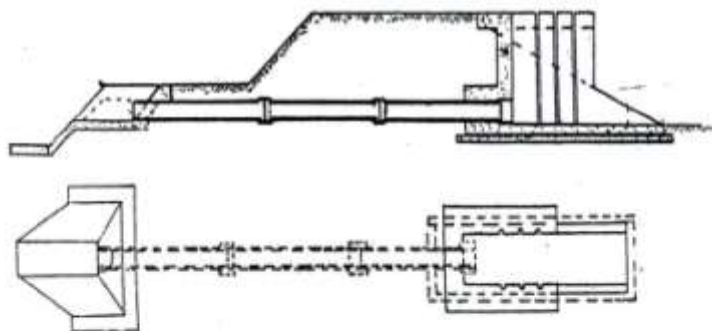
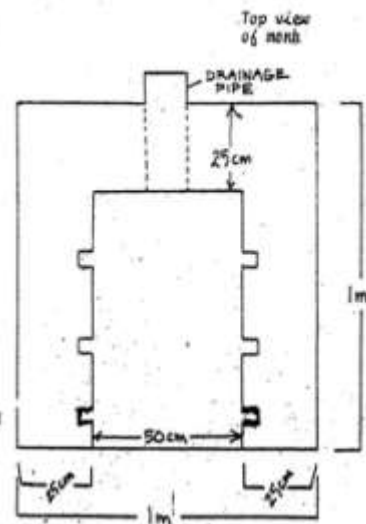

Fig. 37a. Detail of concrete monk gate for brackishwater pond

Fig. 37c. Top view of a monk gate



## Compartments/parts of water control gates (main gate)

- a. Floor –serves as the foundation of the structure and this must be lower than the pond bottom elevation. The floor of the main gate must not be exposed during extreme low tides.
- b. Apron – the apron generally rest on the foundation piles which are made of seasoned bamboo driven at 0.3 m intervals into the soft soil with the butt end up. This serves as the protection to scouring and future seepage of water at the gate's sides.
- c. Cut-off walls – these are provided at both ends of the gate floor to prevent seepage and undercutting of water over the gate's foundation. They extend down into the soil at a minimum depth of 0.6 m.
- d. Side or breast walls – side walls define the sluice way in addition to being retaining walls for the dike fill. Grooves or double cleats for flashboards and screen are built on these walls. The top of these walls are as high as the top of the dike.
- e. Wing walls – these provide the transition from the sluice way to the main canal in addition to retaining the earth at both sides of the gate. The best angle of inclination towards the outside is 45°.
- f. Bridge or catwalk – this is a reinforced concrete slab or thick wooden planks and span the side walls.
- g. Flashboards – slabs or flashboards are generally wooden planks, 2.5–5 cm thick and 30 cm wide inserted into grooves or double cleats. They are used to control the amount of water flowing through the gate.
- h. Screen – these are usually made of wood bamboo strips or of fine polyethylene mesh. They restrict the entry of predators into the ponds.
- i. Pillars – in wooden gates, these are vertical supports where wooden walls are nailed.
- j. Braces – they keep the steady opening of the gate.

## Other pond support structures:

- a. Water supply canals (WSC) – these canals serve the purpose of supplying and draining water to and from the pond. The main water supply canal starts from the main gate and usually transverses the central portion of the fish farms. The slopes towards the gate floor. A 10-15 ha pond is provided with WSC having a width of at least 3 meters.
- b. Drainage canals (DC) – these are support structures usually constructed at the outer sides of the pond parallel or perpendicular to the WSC. These are recommended in intensive culture, especially of shrimps, to effect flow-through system and better water management.
- c. Flumes – are open channels or elevated canals constructed on top of the dike for purpose of supplying well-oxygenated water into various pond compartments. These can be made of concrete hollow blocks, prefabricated concrete slabs, or marine plywood. These are recommended in semi-intensive and intensive prawn farming.
- d. Pumps – are machines used in pumping water into and out of the ponds. These are very necessary during the dry season when water level is low and the salinity of brackish water ponds becomes too high (above the optimum).
- e. Aerators – these are devices used to supply oxygen or agitate or break up the water surface to effect the fast transfer of oxygen from air to water at times when the oxygen in the pond is at critical level, e.g. <3-4 mg/l (ppm), and to remove the excess oxygen in the pond as well as toxic gases such as ammonia (NH<sub>3</sub>), carbon dioxide (CO<sub>2</sub>), and hydrogen sulfide (H<sub>2</sub>S).



## How Much Have You Learned?

### Self-Check 1.1

I. Identify the following. Choose your answer in the box and write it on the blanks provided.

Scale	sheet number
Legend	layout
Sheet name	scale
Linear	edition note
smaller	map

- \_\_\_\_\_ 1. A series or system of items of increasing or decreasing size, value and etc.
- \_\_\_\_\_ 2. A graphical representation of the ground drawn to scale.
- \_\_\_\_\_ 3. This should be placed on top of the map.
- \_\_\_\_\_ 4. If you want to check the correctness of the work, multiply the line measurement in the drawing (in cm) by the given scale (also in cm) divide by 100cm/m to determine the \_\_\_\_\_ measurement of the ground surface.
- \_\_\_\_\_ 5. This should be placed on the lower right-hand corner of the map.
- \_\_\_\_\_ 6. This should be placed on the lower left-hand corner of the map.
- \_\_\_\_\_ 7. This should be placed on the upper right-hand corner of the map.
- \_\_\_\_\_ 8. This is equal to the map or drawing distance (m) over the ground distance (m).
- \_\_\_\_\_ 9. If scale is changed to a bigger value, the drawing or figure of the same dimensions of a lot becomes \_\_\_\_\_.
- \_\_\_\_\_ 10. The manner in which something is displayed or laid out.

II. Identify the following. Choose your answer in the box and write it on the blanks provided.

Conventional layout	fishpond
Progressive layout	diversion pond
Parallel type	multiple stock/harvest system

- \_\_\_\_\_ 1. An artificial body of water surrounded by dikes and with accessories such as gates, pipes and canals to facilitate water supply management.
- \_\_\_\_\_ 2. Compartment of fishpond where fish fry and fingerlings are being reared.
- \_\_\_\_\_ 3. The largest compartment in the pond system. Used for raising fingerlings up to marketable size.
- \_\_\_\_\_ 4. Freshwater pond layout where it is consist of one sluice gate and long water supply canal.
- \_\_\_\_\_ 5. Consists of one sluice gate; long supply canal, and secondary gates provided for to different compartments of progressively increasing areas.
- \_\_\_\_\_ 6. . A brackish water pond system layout where nursery pond (NP) comprises about 4% of the transition pond area (TPA). The transition pond (TP) covers only 6% of the TPA.
- \_\_\_\_\_ 7. A pond type that has a diversion canal to serve as a passageway of water from the main water body, e.g. creek, brook and the like.
- \_\_\_\_\_ 8. A type in which ponds are built parallel to each other and each pond of which has an inlet and an outlet.
- \_\_\_\_\_ 9. A brackish water pond layout where the general practice is to stock at different times, different size, and group of fingerlings and harvests the bigger one's selectively with the use of the gill net.
- \_\_\_\_\_ 10. A freshwater pond layout that has one sluice gate; wide and short supply canal; and secondary gates in the different compartments.

III. Identify the following. Choose your answer in the box and write it on the blanks provided.

Main gate	Berm
Sluice gate	Crown
Freeboard	Drainage canal
Main dike	Secondary dike
Water supply canal	0.3 – 1 meter

- \_\_\_\_\_ 1. The dike that encloses and protects the entire pond system.
- \_\_\_\_\_ 2. The additional height of a structure, e.g. main dike, above high water level to prevent overflow.
- \_\_\_\_\_ 3. Classification of dike which are smaller than the main dike with gradual slope and which enclose NPs, TPs, and RPs.
- \_\_\_\_\_ 4. Is otherwise known as the top width of a dike.
- \_\_\_\_\_ 5. Is a narrow path or footwalk reserved between the base of the dike and the excavated pond. It also serves in fortifying the dike and in holding or trapping eroded soil from the dike top and wall.
- \_\_\_\_\_ 6. Is/are the largest and tallest gate/s as waterway depending the size of the entire pond system.
- \_\_\_\_\_ 7. Height of the main dike should be \_\_\_\_\_ higher than the highest water level in the site.
- \_\_\_\_\_ 8. Pond gates constructed open on top (not concealed) across the dikes with 2 pairs of grooves provided at the central portion of the sidewalls for fitting the slabs and another 2 pairs for each of the gate ends for the screens.
- \_\_\_\_\_ 9. These are support structures usually constructed in the outer sides of the pond parallel or perpendicular to the WSC. These are recommended in intensive culture, especially of shrimps, to effect flow-through system and better water management.
- \_\_\_\_\_ 10. These canals serve the purpose of supplying and draining water to and from the pond. The main water supply canal starts from the main gate and usually transverse the central portion of the fish farms.

**Refer to the Answer Key. What is your score?**



## How Do You Apply What You Have Learned?

**Show that you learned something by doing this activity.**

### Activity Sheet 1.1

#### Scaling Procedure

##### Procedures:

1. Visit your available aquaculture facility in school.
2. Measure the area of the given facility.
3. Compute the scale to be used in drawing the given facility.
4. Using a bond paper, pencils, and ruler, draw the given facility based on the scaling procedure.
5. Indicate the marginal information in your drawing.
6. If you have queries, ask your teacher. You may also go back to the information sheets for clarification.
7. Submit your drawing to your teacher and be prepared to present this to your classmates.

### Activity Sheet 1.2

#### Fishpond layout and design

##### Procedures:

1. Recall your visit in the aquaculture facility in your school. What kind of fishpond system did you observed? In this activity, you will have to draw the layouts of the different fishpond systems.
2. Prepare the following for this activity:
  - Bond paper
  - Pencils
  - Ruler
3. Using the materials above, draw the layouts of the following fishpond systems:
  - a. Brackish water fishpond system
    - Conventional pond system
    - Modular pond system
    - Multiple stock/harvest system
  - b. Fresh water fishpond system
    - Barrage pond

- Diversion pond

4. Use the appropriate scale for brackish water pond system.
5. If you have queries, ask your teacher. You may also go back to the information sheets for clarification.
6. Submit your drawing to your teacher and be prepared to present this to your classmates.

### Activity Sheet 1.3

## Pond water control structures

Procedures:

1. Recall your visit to the aquaculture facility in your school. What kind of fishpond system did you observed? In this activity, you will have to draw the layouts of the different fishpond systems.
2. Prepare the following for this activity:
  - Bond paper
  - Pencils
  - Ruler
3. Using the materials above, do the following:
  1. Draw the different types of dikes. Label its parts.
    - a. Main dike
    - b. Secondary dike
    - c. Tertiary dike
  2. Draw the different types of gates. Label its parts.
    - a. Concrete main gate
    - b. Wooden secondary gate
    - c. Concrete secondary gate
4. If you have queries, ask your teacher. You may also go back to the information sheets for clarification.
5. Submit your drawing to your teacher and be prepared to present this to your classmates.



## How Well Did You Perform?

**Find out by accomplishing the Performance Criteria Checklist honestly and sincerely. Remember it is your learning at stake!**

### Performance Criteria Checklist for Activity Sheet 1.1, 1.2 and 1.3

Has/Have the student/s...	YES	NO	N/A
1. identified the different compartments of a pond?.			
2. used signs and symbols of plan according to fishpond engineering standards.			
3. drawn the layouts of different pond designs according to established procedures?			
4. drawn the following layouts properly?			
a. Conventional pond system			
b. Modular pond system			
c. Multiple stock/harvest system			
d. Barrage pond			
e. Diversion pond			
5. used an appropriate scale for the brackish water pond system?			
6. drawn and labeled the parts of the different types of dikes?			
a. main dike			
b. secondary dike			
c. tertiary dike			
7. drawn and labeled the parts of the different types of gates?			
a. Concrete main gate			
b. Wooden secondary gate			
c. Concrete secondary gate			

Student's Name \_\_\_\_\_ Date \_\_\_\_\_

Comments/Suggestions:



## LEARNING OUTCOME 2

**Draw layout plan for tanks**

## PERFORMANCE STANDARDS

- Different life support systems for tanks are identified.
- Signs and symbols of plan are used according to fishpond engineering standards.
- Layout of different tank designs are drawn according to established procedures



## Materials

- Bond paper
- Pencils
- Ruler



## What Do You Already Know?

Let us determine how much you already know about the layout plan for tanks  
Take this test.

Pretest LO 2

Choose and encircle the letter of the correct answer.

- How to remedy a tank with low dissolved oxygen?
  - Start the blower
  - Start the water pump
  - Start the puddle wheel
  - Start the electric fan beside the tank
- \_\_\_\_\_ are small aquatic organisms raised in tanks, which are commonly used as the first food of young fin fishes?
  - Larvae
  - Phytoplanktons
  - Rotifers
  - Microalgae
- What is the term used to indicate a large container of liquid usually used in culturing fish?
  - reservoir
  - tank
  - basin
  - fishpond
- Why is it necessary to design the tanks in the hatchery?
  - To have beautiful tanks
  - To create beautiful arrangement of tanks.
  - To have uniform size and shape of tanks
  - To conform with the characteristics of the target species of fish
- What is the first phase of a fish production system?
  - construction of aquaculture facilities
  - hatchery
  - nursery
  - grow-out

6. Separating suspended solids from water such as silt, debris and foreign organisms can be done with the use of \_\_\_\_\_.
- a. fine mesh screen
  - b. secchi disk
  - c. filtration units
  - d. intake structure
7. Early stage of the fish life cycle?
- a. egg
  - b. fingerling
  - c. larvae or fry
  - d. post fingerling
8. The sand filter tank is set up with how many layers of different filter media?
- a. 2
  - b. 4
  - c. 5
  - d. 3
9. What is the shape of the broodstock tank?
- a. triangular
  - b. rectangular
  - c. square
  - d. circular
10. Where are newly hatched fish eggs placed?
- a. hatchery tank
  - b. broodstock tank
  - c. nursery tank
  - d. growout tank



## What Do You Need To Know?

Read the Information Sheet 2.1 very well then find out how much you can remember and how much you learned by doing Self-check 2.1.

Information Sheet 2.1

### Fish tank layout and design

A tank is a large rectangular, square or circular container of liquids, usually used in culturing fish.

#### **HATCHERY TANK DESIGN**



Figure 1. Rectangular and circular tanks.

The hatchery is the first phase of a production system aimed at producing fish for human consumption. The next phase is the nursery tank. The final phase is grow out culture in ponds, pens, tanks or cages where fish are grown to marketable size.

The hatchery is a place for the production of fish eggs, larvae, and /or fish fry. In practical terms, a hatchery is a building that houses tanks and equipment for eggs cultivation and rearing of larvae. It is an artificial life-support system for fish taken out of its natural habitat.

The hatchery tanks should be designed in such a way that it provides for ease of operation and it should also be free from work hazards. The design and layout should take into account the need for the hatchery to expand in the future, so space should be left for future tank construction, water, and air supply, etc.

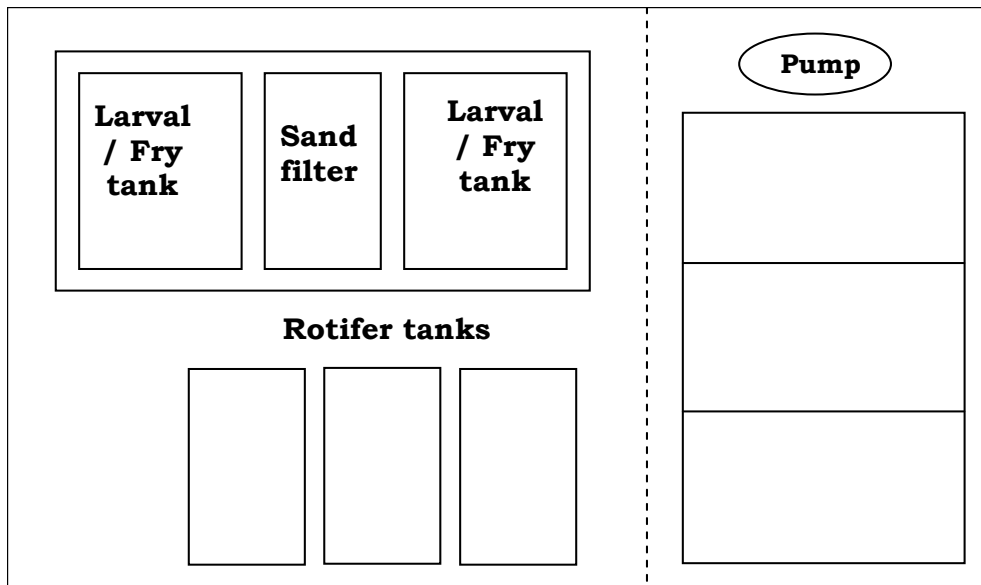

Figure 2 Basic layout for a small- scale hatchery with 2 larval tanks, 1 sand filter, and 3 rotifer tanks in indoor section, a pump house and 3 microalgae tanks at the outdoor section.

### Tank design and description

The essential type of tanks required in small scale hatcheries that are 1 meter deep are:

1. Sand filter tank – set up with layers of different filter media. Water is pumped in at the top of the tanks to flow to the various media, and out the bottom of the tank.

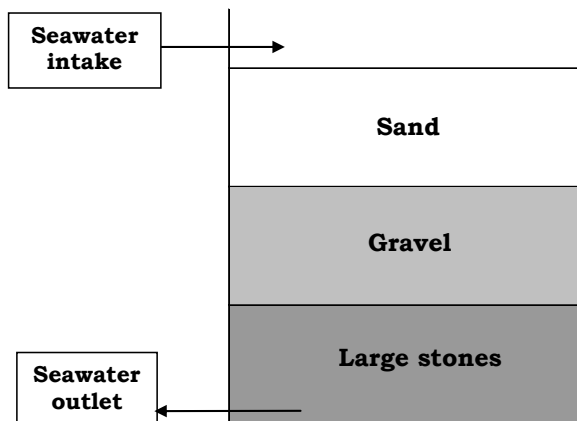

Figure 3. Concrete sand filter tanks for a small hatchery with a capacity approximately 10 m<sup>3</sup>

2. Larval rearing tank – about 6 m<sup>3</sup> capacity. Generally, this is a rectangular or square concrete tank that is usually 1 meter deep. Capacity can range from 6-10 m<sup>3</sup>.



Figure 4. Larval Rearing Tank

3. Live food production tanks. Microalgae production tanks are usually located outside the hatchery building and are not roofed.



Figure 5. Live Food Production Tanks.



Figure 6. Small fiber-glass tank (1 to 2 m<sup>3</sup> capacity), for rotifer enrichment.

### Designing Tanks for Culturing Fish

There are various ways of designing fish tanks. These may be concrete, rectangular or square, hexagonal or octagonal fish tanks and the circular tanks. Tanks for grow out are typically 4-10 m in diameter, and 1-3 m deep.



Figure 7. Rectangular tanks



Figure 8. Drain hall



Figure 9. Outlet hole



Figure 10. Drainage canal

The concrete rectangular tank drain hole fitted with a 3-inch PVC pipe is situated at the rear end of the tank (figure 7). The tank floor should have a slight slope towards the drain hole. The slope is 5 degrees to 15 degrees for easy draining, cleaning and for maintaining purposes.

The outlet hole (figure 9) is used for draining water from the tank. The drainage canal (figure 10) is where the water drained from the tank passes out from the tank site.



Figure 11. The circular and hexagonal fish tanks

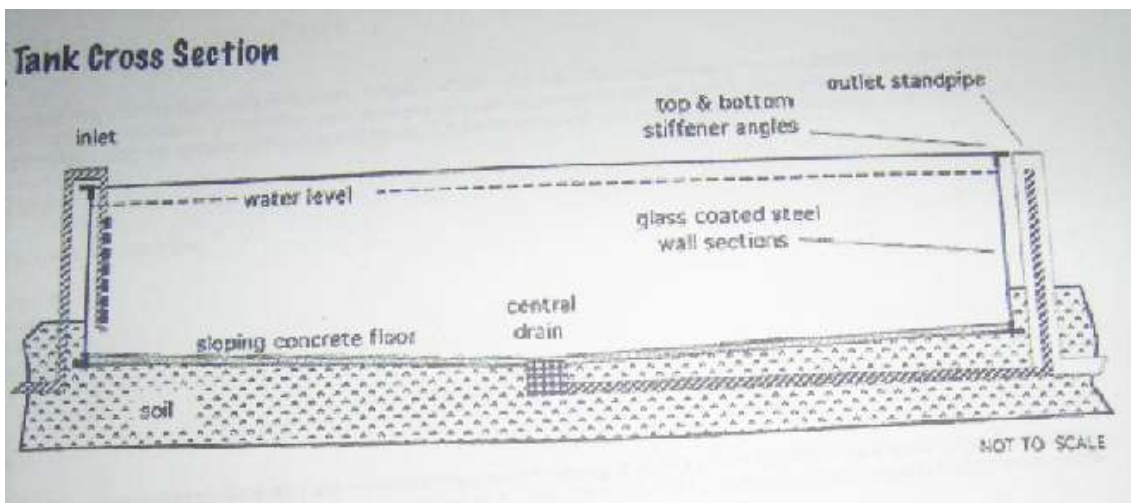

Figure 12. The cross section of a circular or hexagonal fish pond

The outlet should be in the middle of the tank. The tank bottom should have a slight slope towards the center where the outlet is constructed.

### Program of Work

Project: Proposed Rectangular Concrete Tank, 8mx2mx1m

Project Cost: P 20,000

SCOPE OF WORK	Percentage	Estimated Cost
I. Excavation	15 %	3,000.00
II. Carpentry works	10 %	2,000.00
III. Masonry works	60 %	12,000.00
IV. Plumbing	10 %	2,000.00
V. Electrical works	5 %	1,000.00
TOTAL		20,000.00

Summary:

- I. Cost of Materials..... Php 12,000.00
- II. Labor..... Php 20,000.00

### Life Support Units

#### A. Sea water supply systems

- intake structure – used to draw water from the sea using electric motor with 746 watts and 1 hp
- filtration unit – used to separate suspended solids from the water, e.g. (fine silts, debris and foreign organisms).
- water pump – made of cast iron, stainless steel, fiberglass or plastic— materials resistant to corrosion. It must also have a self-priming water pump reservoir – provides a ready source of water for use in any eventuality for reservoirs constructed out of a concrete mix

#### B. Fresh water supply system

A hatchery of either saline or fresh water fin fish and shell fish shall also require a standby water pump and accessories to use in drawing water from a well or other sources in case natural water supply is a problem

- air supply system. A blower is always necessary to supply a high volume of air at low pressure in the hatchery. At least one blower with 1-2 hp capacity is needed although 2 units are better. These will be used in 24-hr cycle, 1 will relieve the other after 12 hours of operation.





Figure 13. Water pump



Figure 14. Blower



Figure 15. Tank with aerators



## How Much Have You Learned?

### Self-Check 2.1

Identify the following. Choose your answer in the box and write it on the blanks provided.

- \_\_\_\_\_ 1. A large container of liquids, rectangular, square or circular in shape usually used in culturing fish.
- \_\_\_\_\_ 2. The first phase of a production system aimed of producing fish for human consumption.
- \_\_\_\_\_ 3. Set up with layers of different filter media.
- \_\_\_\_\_ 4. Tanks are usually located outside the hatchery building and are not roofed usually for the production of microalgae.
- \_\_\_\_\_ 5. Used for draining water from the tank.
- \_\_\_\_\_ 6. Used to draw water from the sea using electric motor with 746 watts and 1 hp.
- \_\_\_\_\_ 7. Used to separate suspended solids from the water, e.g. fine silts, debris and foreign organisms.
- \_\_\_\_\_ 8. Made of cast iron, stainless steels, fiber glass or plastic is to be used, for this is no subject to corrosion. It must also be a self-priming.
- \_\_\_\_\_ 9. Provides a ready source of water for use in any eventuality for reservoirs constructed out of a concrete mix.
- \_\_\_\_\_ 10. Used to supply high volume of air at low pressure in the hatchery.

Intake structure	Filtration unit
Hatchery	Outlet hole
Blower	Water pump
Sand filter tank	Water pump reservoir
Live food production tank	Tank

**Refer to the Answer Key. What is your score?**



## How Do You Apply What You Have Learned?

Show that you learned something by doing this activity.

### Activity Sheet 2.1

## Fish Tank Layout and Design

Procedures:

1. Recall your visit to the aquaculture facility in your school. What are the different components of a fish tank? In this activity, you will have to draw the layout of different fish tanks, including the life support system.
2. Prepare the following for this activity:
  - Bond paper
  - Pencils
  - Ruler
3. Using the materials above, draw the layouts of the following fish tanks:
  - Hatchery tank
  - Sand filter tank
  - Larval rearing tank
  - Live food production tank
4. Use an appropriate scale.
5. If you have queries, ask your teacher. You may also go back to the information sheets for clarification.
6. Submit your drawing to your teacher and be prepared to present this to your classmates.



## How Well Did You Perform?

**Find out by accomplishing the Performance Criteria Checklist honestly and sincerely. Remember it is your learning at stake!**

### Performance Criteria Checklist for Activity Sheet 2.1

Has/Have the student/s...	YES	NO	N/A
1. identified different life support systems for tanks are?			
2. used signs and symbols of plan according to fishpond engineering standards?			
3. drawn the layout of different tank designs according to established procedures?			
4. drawn the following layouts properly?			
• Hatchery tank			
• Sand filter tank			
• Larval rearing tank			
• Live food production tank			
5. used an appropriate scale in drawing?			

Student's Name \_\_\_\_\_ Date \_\_\_\_\_

Comments/Suggestions:

## LEARNING OUTCOME 3

**Draw layout plan for pens and cages**

### PERFORMANCE STANDARDS

- Different life support systems for pens/cages are identified.
- Signs and symbols of plan are used according to fishpond engineering standards.
- Layout of different pens/cages designs are drawn according to established procedures.



### Materials

- Bond paper
- Pencils
- Ruler



## What Do You Already Know?

Let us determine how much you already know about the layout plan for pens and cages. Take this test.

### Pretest LO 3

Directions: Choose the best answer for each number by encircling the letter of your choice.

1. What factor usually determines the depth of fish cages?
  - a. capability of the owner
  - b. natural productivity of the water
  - c. the mooring system
  - d. the species of fish to be cultivated
  
2. What is the smallest unit of a net?
  - a. mesh
  - b. mesh size
  - c. knots
  - d. twine
  
3. In order to make the fish cage float on the water, the cage must be equipped with \_\_\_\_\_.
  - a. mooring system
  - b. netting system
  - c. framework
  - d. floatation system
  
4. As a general rule, what is the length of the mooring lines?
  - a. two times the depth of water
  - b. three times the length of the cage
  - c. three times the depth of the water
  - d. with two meters allowance during high tide

5. Which of the following keeps the whole cage in a certain location and prevents the cage from drifting along with the water current?
- mooring
  - floater
  - framework
  - barrier
6. Part of the cage that serves as the walkways for working, feeding and monitoring?
- frames
  - floaters
  - mooring
  - nets
7. What type of net cage fabrication refers to a  $\frac{1}{4}$  inch mesh?
- CC-net
  - DD-net
  - B-net
  - knotless NET
8. What aquaculture facility is usually supported by a fixed rigid framework of bamboo poles, palm tree poles and wood poles?
- floating fish cage
  - fish pen
  - fixed fish cage
  - happa
9. Generally, they are the most suitable in relatively large bodies of water and along protected coastal areas where level ranges from 2.0 meters to a maximum of 7.0 meters.
- floating fish cage
  - fish pen
  - fixed fish cage
  - fishpond

10 In general, which aquaculture facility has the biggest area?

- a. fixed fish cage
- b. floating fish cage
- c. happa
- d. fish pen





## What Do You Need To Know?

Read the Information Sheet 3.1 very well then find out how much you can remember and how much you learned by doing Self-check 3.1.

Information Sheet 3.1

### **Fish pens and cages layout and design**

A **Fish cage** is a structure fully enclosed by nets on all sides and bottom supported either by a fix rigid frame or by floats which rise and fall with the water level or tide.

A **Fish pen** is an area enclosed by nets on all sides and utilizes the lake bed and other bodies of water as the bottom enclosure.

Before making the layout of the cage/pen, the size, depth and shape must be considered which is dependent mainly on the ability of the owner as far as operation and maintenance is concerned. The biology and behavior of the target specie and the characteristics of the project site should be considered as well. The design must be simple but durable, easy to construct, and economical.

#### **Determining the size, depth and shapes of facilities and target species of fish.**

In Laguna Lake, Philippines, size of pens range from less than one hectare to more than 100 hectares. The shape of the enclosure is influenced by the characteristics of the cultured fish. For milkfish and tilapia, square and rectangular pens are commonly used. Circular enclosures are recommended for big head carp. Generally, the most economical shape of the pen is one that has the least perimeter. Circular shape require the least materials per unit area but they are relatively hard to construct.

Generally, fish pens are most suitable in relatively large bodies of water and along coastal protected areas where the water level ranges from 2.0 meters to a maximum of 7.0 meters.

On the other hand, the depth of the cage is usually determined by the natural productivity of the water. Since natural food production is relatively higher on the surface, sunlight penetration is usually employed as the basis for depth.

#### **TYPES OF CAGE**

##### **A. Fixed type**

The fixed types of fish cages are suitable for relatively shallow areas. They are usually installed near shore or in shallow lakes like Laguna de Bay where water depth is less

than five meters. In fixed type cages, synthetic net cages are attached to bamboo poles staked to the bottom for support. Size of cages range from 5m x 15m with net mesh sizes of 5-15 mm.

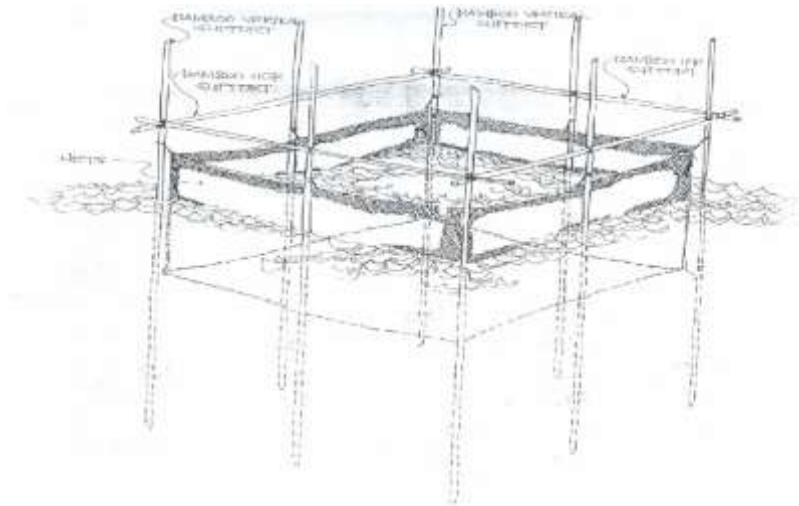

Figure 1.Fixed fish cage.

## B. Floating type



Figure 2.Floating fish cage.

The floating types of fish cages are suitable for depths exceeding five meters. Floating net cages are typically suspended from bamboo raft with or without plastic drums or any other floating materials to float. Cages have a net mesh size of 15 mm vary in size from 15 x 10m to 20m x 15 m and have a depth of 5-6 m.



2. Enclosure and barrier nets
  - a. polyethylene nets
  - b. polypropylene nets
  - c. nylon nets
  - d. woven bamboo splits



polyethylene net



polypropylene net



nylon net

3. Tying and braiding nets
  - a. polyethylene rope and twine
  - b. polypropylene rope
  - c. nylon threads
  - d. nylon cord (monofilament)
  - e. rubber tire strips



polyethylene rope



polyethylene twines



polypropylene rope



nylon thread



nylon cord



rubber strips

## B. Fish Cage

### 1. Framework/ structure

- a. bamboo- most common
- b. wooden poles
- c. anahaw (palm tree) logs
- d. creosoted pole
- e. steel/ G.I. pipe

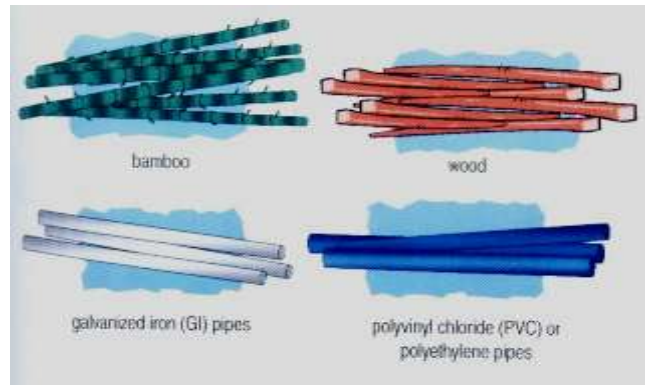

Figure 5. materials that can be used for frame.

### 2. Enclosure and barrier nets

- a. polyethylene nets
- b. polypropylene nets
- c. nylon nets
- d. woven bamboo splits

### 3. Tying and Braiding

- a. polyethylene rope and twine
- b. polypropylene rope
- c. nylon threads
- d. nylon cord (monofilament)
- e. rubber tire strips

### 4. Floats

- a. bamboo
- b. steel drum/ barrel
- c. Styrofoam
- d. plastic container
- e. aluminum cylinder
- f. PVC pipes
- g. Rubber tires



Figure 6. Commonly used materials for floaters.

## 5. Sinkers

- a. stone
- b. concrete slabs
- c. bamboo and wooden pegs

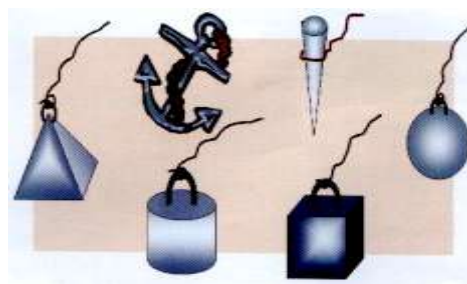

Figure 7. Materials used for sinkers.

### Types of nets and mesh sizes suitable for fish pen and fish cage

Generally, the most suitable nets should be flexible or adaptable for easy handling. They should be resistant to foul growth, heat, and ultraviolet rays.

The mesh size to be used must be small enough to prevent the escape of fish and entry of predators. For hatchery operations of tilapia, the most common sizes of mesh used are 0.5 mm (happa) for breeding, 10 mm for nursery and 20 mm for grow-out. However, as long as the fish cannot escape, large meshes are recommended, since they provide large passageways for water circulation, slower rate of fouling, easier to handle and less expensive per unit area.

### Type of nets for cage fabrication

- B- NET (1/4 " mesh)
- DD- NET (3/8 " mesh)
- CC-NET (1/2 " mesh)

There are many kinds of nets that can be used for fabrication. The most common are the B-net (1/4" mesh), DD-net (3/8" mesh), and CC-net (1/2"). However, the most popular is the B-net because smaller fingerlings do not need a nursery cage. It is cheaper per unit area because it is wider (108 inches) than the other nets, hence, labor cost in fabricating cages is much lower, and tearing of one or two mesh do not easily provide an escape route for bigger fish.

### *Floating system (floating fish cage)*

The floats to be used in floating cages must have the following:

- a. High buoyancy
- b. resistance to fouling
- c. ability to withstand forces of the wind and waves

For longer life and less fouling, floats used may be covered with protective materials such as rubberized canvas.

### **Mooring system**

Mooring lines should be light and strong, flexible, highly resistant to fatigue, impact, abrasion, stretch and twisting. As a general guide, the length of the mooring lines should be three times the depth of water.

Materials commonly used in the fabrication of synthetic fiber ropes are:

- a. nylon (polyamide)
- b. Dacron (polyester)
- c. Polypropylene
- d. Polyethylene

Nylon is recommended because of its strength and high shock absorption.

### **Anchor (floating fish cage)**

An ideal anchor must provide enough holding power with reasonable weight size. The type of anchor to use in the mooring system depends on the depth of water, nature of bottom, and current. The three types of anchors are:

1. Dead weight anchors- they are recommended for mooring that involves essentially vertical tension. A typical example is a concrete block.



2. Embedment anchors- designed to dig into the bottom as they are being pulled by a horizontal force. It is recommended for sandy and muddy bottom.



3. Special anchors- are combinations of deadweight and embedment anchors. They are designed to resist vertical and horizontal components of tension.

## Floating Fish Cage

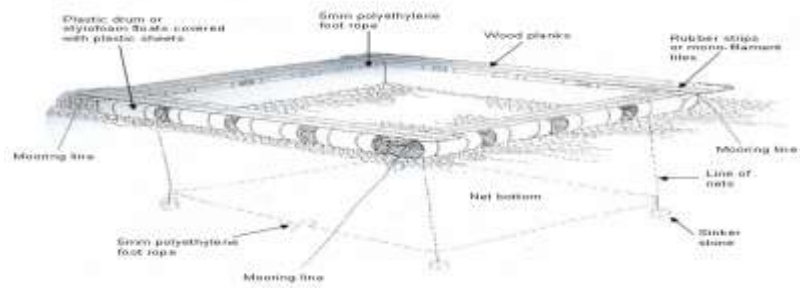

Figure 8. floating fish cage





## How Much Have You Learned?

### Self-Check 3.1

Identify the following. Choose your answer from the box and write it on the blanks.

- \_\_\_\_\_ 1. A structure fully enclosed by nets on all sides and bottom supported either by a fix rigid frame or by floats which rise and fall with the water level or tide.
- \_\_\_\_\_ 2. An area enclosed by nets on all sides, which utilizes the lake bed and other bodies of water as the bottom enclosure.
- \_\_\_\_\_ 3. A heavy object, usually a shaped iron weight with flukes, lowered by a cable or chain to the bottom of a body of water to keep a vessel from drifting.
- \_\_\_\_\_ 4. The smallest unit of a net.
- \_\_\_\_\_ 5. A structure, usually rigid, serving to hold the parts of something together or to support something constructed.
- \_\_\_\_\_ 6. A lump made by intertwining thread, in which one free end is passed through a loop and drawn tightly.
- \_\_\_\_\_ 7. The distance between the centers of the opposite knots in the same mesh when it is fully extended at the right angles to the continuing direction of the twines.
- \_\_\_\_\_ 8. A fabric of thread, cord, rope or twine woven or knotted to form an open pattern or mesh used to catch fish.
- \_\_\_\_\_ 9. The process by which an object or materials get extremely dirty or impure, disgustingly filthy, or offensive to the senses,
- \_\_\_\_\_ 10. The lines, cables, etc. by which water craft or any floating objects or moored or held in place.

Mooring	Mesh size
Fish cage	Net
Framework	Anchor
Fish pen	Knot
Fouling	Mesh

**Refer to the Answer Key. What is your score?**



## How Do You Apply What You Have Learned?

**Show that you learned something by doing this activity.**

### Activity Sheet 3.1

#### **Pens/Cages Layout and Design**

Procedures:

1. Prepare the following for this activity:
  - Bond paper
  - Pencils
  - Ruler
2. Using the materials above, draw the layout of a 5m x 5m x 3m floating fish cage.
3. Include in your drawing the anchors used, attached to the mooring lines.
4. Label its parts.



## How Well Did You Perform?

**Find out by accomplishing the Performance Criteria Checklist honestly and sincerely. Remember it is your learning at stake!**

### Performance Criteria Checklist for Activity Sheet 3.1

Has/Have the student/s...	YES	NO	N/A
1. identified different life support system for pens/cages?			
2. used signs and symbols of plan according to fishpond engineering standards?			
3. Drawn the layout of different pens/cages designs according to established procedures?			
4. drawn the layout of a floating fish cage?			
5. included the anchors used in your drawing?			
6. labelled the parts of a floating fish cage?			

Student's Name \_\_\_\_\_ Date \_\_\_\_\_

Comments/Suggestions:



**Congratulations! You did a great job! Rest and relax a while then move on to the next lesson. Good luck!**

## REFERENCES

### LO1

- Cagauan A.G., Tilapia Grow Out Systems and Operation
- Calmorin L. P., Calmorin M. A., Tinaypan A. S., Introduction to Fishery Technology REGION 02, Technoguide for Tilapia
- Rosel R.N. Tilapia Grow-out in Freshwater Fishpond
- Sarmiento R.S. Module in Fishpond Engineering and Management
- Toledo, C.F. Breeding and Hatchery Management
- CBLM, Fish Culture NC II, 3<sup>rd</sup> Year, Module II. Pages 1-10.
- <http://www.answers.com/topic/plan>

### LO 2

- Castanos M.T. SEAFDEC Asian Aquaculture
- [info@aquacare.com](mailto:info@aquacare.com)
- Patadjai R.S. Article from SEAFDEC Asian Aquaculture
- Sim S.Y., Rimmer M.A., Toledo J.D., Sugama, S., Rumengan I., Williams, K.C., Philips, M.J. 2005. A Guide to Small-Scale Marine
- Finfish Hatchery Technology
- Toledo C.F. Breeding and Hatchery Management
- CBLM, Fish Culture NC II, 3<sup>rd</sup> Year, Module II. Pages 11-19.

### LO 3

- Cagauan, A. G. Tilapia Grow Out Systems and Operation Manual, CLSU Nueva Ecija
- Lasam, G. D. Technoguide for Tilapia. Department of Agriculture- Region 2
- Vivar, A. V. SEAFDEC Aquaculture Department
- CBLM, Fish Culture NC II, 3<sup>rd</sup> Year, Module II. Pages 20-35.

## LESSON 4

### Apply Safety Measures on Farm Operations



#### LEARNING OUTCOMES:

At the end of this Lesson, you are expected to do the following:

- LO 1. apply appropriate safety measures
- LO 2. safe keep/dispose tools, materials, and outfit



## Definition of Terms

<b>Cleaning</b>	the removal of visible soil but not necessarily sanitized.
<b>Contamination</b>	the unintended presence of harmful substances.
<b>Hazard</b>	biological, chemical or physical agent that may cause an unacceptable consumer health risk.
<b>Outfits</b>	personal protective equipment such as masks, gloves, boots, socks etc.
<b>Precautionary measures</b>	measures adopted beforehand against possible danger.
<b>Safety</b>	protecting oneself and others from possible danger and injury.
<b>Safety measures</b>	an art of preventing the occurrence of an accident by removing the presence of hazards.
<b>Waste products</b>	worthless things.

## LEARNING OUTCOME 1

**Apply appropriate safety measures**

## PERFORMANCE STANDARDS

- Safety measures are applied based on work requirement and aquaculture procedures.
- Tools and materials are utilized in accordance with specification and procedures.
- Outfit is worn in accordance with farm requirements.
- Shelf life and/or expiration of materials are effectively checked against manufacturers' specifications.
- Hazards in the workplace are identified and reported in line with farm



## Materials

- Script
- First aid kit
- Personal Protective Equipment (PPE)
- Props, tools, materials, and chemicals for the role play
- Video camera





## What Do You Already Know?

Let us determine how much you already know about the appropriate safety measures while working in the farm. Take this test.

Pretest LO 1

Choose the letter of the correct answer.

1. Why are shells of snails and other foreign materials removed before pond leveling?
  - a. To prevent the pond water from fouling.
  - b. To avoid the workers' feet from incision or puncture from these shells.
  - c. The composting shells may increase alkalinity of the soil.
  - d. The shells contribute water turbidity.
2. Why it is important for a student to wear a hat and long sleeve working clothes in pond draining?
  - a. To prevent his skin from getting dark.
  - b. To protect him from getting dirty from soft mud.
  - c. To protect him from over exposure to heat and sunlight.
  - d. All of the above.
3. What is the proper tool used to dig the soil to form a mud block?
  - a. Crow bar
  - b. Grub hoe
  - c. Shovel
  - d. Digging blade
4. In cleaning the dikes, what should be worn to be safe from snake bites?
  - a. Long sleeve clothing
  - b. Boots
  - c. Steel-capped foot wear
  - d. Rubber gloves and shoes
5. Which equipment is to be used to protect feet from puncture, incision and other injuries while leveling the pond bottom?
  - a. Boots
  - b. Barrier cream
  - c. Gloves
  - d. Socks



## What Do You Need To Know?

Read the Information Sheet 1.1 very well then find out how much you can remember and how much you learned by doing Self-check 1.1.

Information Sheet 1.1

### **Safety measures while working in farm using chemicals and hazardous tools and equipment**

In performing any kind of work in the farm, safety rules should be strictly followed to avoid accidents.

#### **Work tasks in pond preparation**

- Draining the pond
- Drying the pond bottom.
- Cultivating the pond bottom.
- Levelling the pond bottom.
- Repairing gates and screens.
- Repairing dikes.
- Controlling competitors and predators
  - Snakes – prey on small fish. Always keep banks and other dikes clean to prevent snakes from harboring in the ponds.
  - Frogs – they eat fry and fingerlings. Their population can be controlled by removing their egg sacks from the pond water.

#### **Place and time for safety measures**

The students are at the workplace during their laboratory period scheduled in the morning. They will spend their time for two hours in the fishpond. Before performing their work tasks, the appropriate tools/materials and outfit must be prepared beforehand. They have already determined the hazards associated to their works. In this way, they are able to prepare themselves for the proper outfit, tools and materials appropriate to the work task.

## Safety Measures

Safety measures to be observed in the following work tasks:

- A. **Pond draining and drying.** Wear a hat and a long-sleeved shirt. Over-exposure to heat and extreme temperature may result in range of injuries from burns to frostbite.



Figure 1. Shovel/water pump/digging blade

- B. **Cultivation of pond bottom.** Use long-sleeved working clothes, a hat, and hand gloves. For small ponds, a shovel or rake is used in tilling or cultivating the pond bottom just after draining. For large pond, a rotavator is used.
- C. **Levelling.** Wear gloves, long-sleeved working clothes, and hat to prevent fingers from possible injuries and to protect skin from direct sunlight of the sun. Remove shell of snails in the pond for these may cause incision or puncture to the feet.



Figure 2. Rake and gloves

- D. **Repairing gates and screens.** Broken or damaged slab and pipes must be repaired. In doing so, use proper tools to avoid accidents.
- E. **Repairing dikes.** Use a digging blade in repairing leakage and seepages of pond dikes. Extra care must be observed so that feet will not be wounded.

- F. **Predator control.** Keep the dikes' banks clean to control predators such as snakes and frogs. Wear boots, hat and long sleeve clothes in clearing the grasses along pond dikes.



Figure 3. Boots, bolo

Considering the nature of the task and the workplace. It is very necessary to use personal protective clothing and equipment appropriate for the task for safety measures.

### **Prepare for farm emergencies**

You need to be ready to deal with emergencies on your farm. To prepare for medical and other emergencies, develop an emergency plan and review it with everyone who might have to deal with an emergency. This will reduce confusion in a real emergency. Review the plan with your local emergency responders. Important parts of your emergency plan:

- Listing possible emergencies - Identify any emergencies that might occur, such as bad weather, fire or explosion, chemical spill, someone becoming entangled in machinery.
- Provide a communication system - How will you know if someone working alone needs help? Consider providing two-way radios, phones or cellular phones for communication. Check in with those working alone regularly through frequent visits or having them check in at regular intervals.
- Planning for action - Write out a plan for each potential emergency. Specify the role of each individual. As injured persons won't be able to carry out their roles in an emergency, have a list of contacts that can fulfill each role in your plan. For example, make sure everyone knows how to shut off machinery. Go over the plan with everyone involved.
- Identifying resources - List everything needed to deal with possible emergencies in all areas of your farm. You should have adequate first aid supplies (restocked periodically) in all work locations and a way to call emergency help. Have emergency information, including directions to the farm, near a phone. Let local emergency service people know the best route to take to your farm. Ensure that you have a way to evacuate a person who may be difficult to reach, for example, a person in a muddy field. Working in remote locations and alone is one of the greatest hazards in farming. Locating someone who has been injured quickly and administering first aid on the scene can lessen the impact of an injury and, in some cases, greatly improve the chances of survival.

## Investigate incidents and near misses

To understand an *incident or near-incident*, you need to find out:

- What caused the incident (immediate events leading up to the incident)?
- What contributed to the incident (such as unsafe activities and conditions)?
- What are the root causes that set the stage for the incident (such as inadequate safety policies, procedures, or attitudes)?
- What are the ways to prevent a similar incident?
- Carefully look at what happened and try to understand why. To do this, you need to consider all potential influencing factors, such as weather, operator training, maintenance, use of equipment and so on. Talk to anyone who saw the incident or was involved in it.

Use these six questions to get the basic information about the incident.

- *Who* was involved?
- *Where* did the incident happen?
- *When* did it happen?
- *What* were the immediate causes?
- *Why* did the incident happen (root cause)?
- *How* can a similar incident be prevented?

Factors to think about include:

- adequacy of planning, training, orientation or supervision (ex: repairing hydraulics on a front-end loader without blocking the arms or bucket)
- poorly designed work areas or job procedures
- inadequate, defective, or obsolete tools, machinery and equipment
- unusual circumstances, such as an emergency that requires workers to perform jobs they don't normally do
- jobs that are rarely performed (ex: silo repairs)

### ***Near misses are free warnings***

*These are learning opportunities that must not be ignored. If something just about happened, it is critical you understand why and take steps to prevent near misses from happening again.*

### **Make your farm a healthier and safer workplace**

Just as you review your other business activities, review your farm safety and health program regularly. Ask your family and workers to suggest improvements and help you detect and fix problems. Agriculture work is always changing. New technologies and problems may require you to:

- re-examine workplace hazards
- update supervisor/worker training
- change how supervising is done
- reassign responsibilities for safety

- review your workplace inspection procedure and conduct safety inspections differently.

Above all else, consider safety and health as an integral component of your farm business management. Your safety and well-being are crucial to your farming operation.

### **Personal protective equipment used in farms**

Whenever you perform a task in the farm you must use personal protective clothing that is appropriate for the task and conforms to your local safety regulations and policies.

- Work clothing—such as overall coats, hat and boots
  - Eye protection such as safety goggles and face masks
  - Hand protection such as gloves and barrier cream
  - Respiratory equipment such as face masks and valve respiration
1. Always wear protective clothing. Avoid wearing loose clothes.
  2. Remove your watches, rings, bracelet and other jewelry when working in the farm
  3. Outfits are worn according to farm requirements and specifications.

Personal Protective Equipment used in farm



Eye glasses



Boots



Long sleeved shirt



Hand gloves



Hat

## **Basic First Aid**

First aid includes any emergency care given to an injured or ill person before medical assistance arrives. Due to the often hazardous nature of farming and isolation all people working on the farm should be trained in basic first aid. At least one person should be trained at a senior or level 2. Regularly check that your first aid needs are in line with the Workcover code of practice in your state.

In the event of a medical emergency:

- check for any threatening situation and remove further danger
- remain with the injured person and provide appropriate first aid
- designate someone to meet the ambulance and direct it to the location of the casualty;
- try not to leave the injured person alone; and
- do not move the injured person unless they are exposed to further injury.

Employers should provide and maintain appropriately stocked first aid kits. Ensure that kits are easily accessible, that everyone on the farm is aware of the location of the kits, and that their location is clearly signed. A list of emergency services, telephone numbers and some basic first aid notes should be located with the kits.

First aid kits should also be located in tractors, trucks and utilities.

There are legislative requirements detailing what should be kept in each kit and this will depend on your location and number of people working on the farm. The kit should at least include:

- band aids
- adhesive tape
- bandages
- eye pad
- tweezers
- latex gloves
- antiseptic wipes
- non-adherent and wound dressings
- plastic bags
- safety pins
- scissors
- saline solutions
- emergency thermal blanket
- first aid book and CPR card
- disposable resuscitation face shields
- disposable gloves

Include a list of the contents with the kit (place on the back of the door or lid).

The farm should also have arrangements for looking after someone who becomes sick at work. This may mean providing a rest area, or sending or taking the person home or to a doctor.

Try to avoid having people work on their own, but when it is unavoidable, make sure someone knows where they are on the farm and when they are expected back. Ensure that they have a mobile phone or some other means of communication with them and a distress alarm in case of an incident. If no one is about, they should leave a note in a conspicuous place. A whiteboard in the workplace is a good idea. First aid is the emergency treatment given to an injured or sick person while waiting for a doctor. This is done by a person with adequate training on the initial treatment of emergency cases.

The DRABCD Action Plan is a vital aid to the first aider in assessing whether the casualty has any life-threatening conditions and if any immediate first aid is necessary.

**D** check for DANGER

- to you
- to others
- to casualty



**R** check for RESPONSE

- is casualty conscious?
- is casualty unconscious?



**A** check AIRWAY

- is airway clear of objects?
- is airway open?



**B** check for BREATHING

- is chest rising and falling?
- can you hear or feel air from mouth or nose?
- if no breathing, give 2 initial breaths

**C** give CPR

- if no signs of life—unconscious, not breathing and not moving, start CPR
- CPR involves giving 30 compressions at a rate of approximately 100 compressions per minute followed by 2 breaths



**D** apply a DEFIBRILLATOR (if available)

- follow voice prompts



## Possible accidents in farm/fishery operation

### Managing snake bite

1. Follow DRSABCD
2. Rest and reassure the patient
3. Apply a pressure immobilization bandage
  - if on a limb, apply a broad pressure bandage over the bite site as soon as possible
  - apply a firm heavy crepe or elasticized roller bandage starting just above the fingers or toes, and moving upwards on the limb as far as can be reached (include the snake bite)
  - apply tightly without stopping blood supply to the limb
4. Splint the bandaged limb
5. Ensure the patient does not move
6. Write down the time of the bite and when the bandage was applied
  - stay with the patient
  - check circulation in fingers or toes

### **WARNING**

- **DO NOT** wash venom off the skin
- **DO NOT** cut the bitten area
- **DO NOT** try to suck venom out of wound
- **DO NOT** use a tourniquet
- **DO NOT** try to catch the snake

### Managing Shock

1. Follow DRSABCD and manage injuries such as severe bleeding
2. Reassure the patient
3. Raise the patient's legs
  - (unless fractured or a snake bite) above the level of the heart, with head flat on the floor
4. Treat any wound or burn, and immobilize fractures
5. Loosen tight clothing around neck, chest and waist

6. Maintain the patient's body warmth with a blanket or similar
  - DO NOT use any source of direct heat
7. Give small, frequent amounts of clear fluid
  - (preferably water) to the conscious patient who does not have abdominal trauma and who is unlikely to require an operation in the immediate future
8. Monitor and record breathing, pulse and skin color at regular intervals
9. Place the patient in the recovery position
  - if there is difficulty breathing
  - if patient becomes unconscious
  - if patient is likely to vomit

#### **NOTE**

*Immediately after injury, there may be little evidence of shock. Signs and symptoms may gradually develop depending on:*

- *severity of the injury*
- *continuation of fluid loss*
- *effectiveness of management*
- *Shock can be life-threatening.*
- *Try NOT to leave a patient suffering from shock unattended.*

#### **Managing Eye Injury**

1. Support patient's head
  - and keep as still as possible
  - ask patient to try not to move eyes
2. Flush eye with cool, running water
  - in the case of chemical or heat burn, or smoke in eyes
3. Place dressing over eye
  - place a sterile pad or dressing over injured eye
  - ask patient to hold pad/dressing in place
  - bandage pad/dressing in place, covering injured eye

- if a penetrating eye injury, lie patient on back, place pad around object and bandage in place

### **WARNING**

- **DO NOT** touch the eye or any contact lens.
- **DO NOT** allow patient to rub eye.
- **DO NOT** try to remove any object which is penetrating the eye.
- **DO NOT** apply pressure when bandaging the eye.

### **Managing heat-induced condition**

#### ***Heat exhaustion***

1. Move the patient to lie down in a cool place with circulating air
2. Loosen tight clothing and remove unnecessary garments
3. Sponge patient with cool water
4. Give fluids to drink if conscious
5. Seek medical aid if patient vomits or does not recover quickly

#### ***Heatstroke***

1. Follow DRSABCD
2. Apply cold packs or wrapped ice to neck, groin and armpits
3. Cover with wet sheet
4. Ensure an ambulance has been called
5. If the patient is fully conscious and is able to swallow, give fluids

### **WARNING**

*Heatstroke is a potentially lethal*



## How Much Have You Learned?

### Self-Check 1.1

#### I. Briefly answer the following questions:

1. What are the safety measures to be observed in the following work tasks:
  - a. Pond draining and drying
  - b. Cultivation of pond bottom
  - c. Leveling
  - d. Repairing gates and screens
  - e. Repairing dikes
  - f. Predator control
2. What are the tools/materials used in tilling or cultivating the small pond bottom just after draining?
3. What are the important parts of an emergency plan?
4. How can you investigate incidents and near misses in your workplace?
5. How can you make your farm a healthier and safer workplace?

#### II. Encircle the letter of the correct answer.

1. Why is it important for a student doing the pond draining to wear hat and a long sleeve working clothes?
  - a. To prevent his skin from getting dark.
  - b. To protect him from getting dirty from soft mud.
  - c. To protect him from over exposure to heat and sunlight.
  - d. All of the above.
2. In cleaning the dikes, what should be worn to be safe from snake bites?
  - a. Long sleeved shirts
  - b. Boots
  - c. Steel-capped foot wear
  - d. Rubber gloves and shoes
3. Which equipment is to be used to protect feet from puncture, incision and other injuries while levelling the pond bottom?
  - a. Boots
  - b. Barrier cream
  - c. Gloves
  - d. Socks

4. Which of the following statements is correct?
  - a. Used PPE even if not working
  - b. Wear fitted clothes
  - c. Jewelry is allowed to be worn when working
  - d. Always wear protective clothing when working
  
5. Personal protective equipment in fishpond operation includes the following except?
  - a. Protective clothing
  - b. Hats
  - c. Boots
  - d. None of the above

III. Write TRUE if the statement is correct and FALSE if incorrect. Write your answer on the blanks provided.

- \_\_\_\_\_ 1. The first aider deals with the whole situation, the injured person, and the injury or illness.
  
- \_\_\_\_\_ 2. Young children and students with communication difficulties are sometimes unable or unwilling to describe the onset of illness or the nature of injury and pain.
  
- \_\_\_\_\_ 3. Preventing first aid will protect health, improve safety, and increase productivity.
  
- \_\_\_\_\_ 4. One way to slow the buildup of heat when wearing personal protective equipment is to use special cooling garments.
  
- \_\_\_\_\_ 5. Controlled bleeding may lead to a condition known as shock.
  
- \_\_\_\_\_ 6. Untreated shock from bleeding will almost always cause death.
  
- \_\_\_\_\_ 7. If you hold one hand above your head and the other at your side, the lower hand will be pale while the higher one will be red.
  
- \_\_\_\_\_ 8. When using pressure points, make sure you are pressing on a point closer to the wound than the heart.
  
- \_\_\_\_\_ 9. An ill person is often irritable, moody and hard to deal with.
  
- \_\_\_\_\_ 10. People work slower and less efficiently when they are suffering from heat stress.

**Refer to the Answer Key. What is your score?**



## How Do You Apply What You Have Learned?

**Show that you learned something by doing this activity.**

### Activity Sheet 1.1

#### **Basic First Aid Practices**

Procedures:

1. Group yourselves into five (5).
2. Think of a scenario in the fish farm where accidents may occur. Ideally choose a scenario that involves working with chemicals.
3. Make a script on this focusing on the following:
  - Application of safety measures while working
  - Appropriate use of the tools, materials and equipment for a certain task.
  - Using personal protective equipment (PPE)
  - Checking shelf life of consumable materials
  - Identification of possible hazards in the workplace
4. Demonstrate or act out/role play the scene.
5. Record the role play and submit the output to your teacher together with your script.



## How Well Did You Perform?

**Find out** by accomplishing the Performance Criteria Checklist honestly and sincerely. Remember it is your learning at stake!

### Performance Criteria Checklist for Activity Sheet 1.1

Have the student/s...	YES	NO	N/A
1. prepared the appropriate script?			
2. demonstrate through role play the following?			
a. utilizing tools and materials in accordance with specification and procedures?			
b. wearing outfits in accordance with farm requirements?			
c. checking shelf life and or expiration of materials effectively against manufacturers' specifications?			
d. Identifying and reporting hazards in the workplace are in line with farm guidelines?			
3. recorded the role play and submitted the project?			

Student's Name \_\_\_\_\_ Date \_\_\_\_\_

Comments/Suggestions:

## LEARNING OUTCOME 2

**Safe keep/dispose tools, materials and outfit**

## PERFORMANCE STANDARDS

- Used tools and outfits are cleaned and stored in line with farm procedures.
- Unused materials are labeled and stored according to manufacturers' recommendation and farm requirements.
- Waste materials are disposed of according to manufacturers, and government and farm requirements.



## Materials

- Camera
- Photos
- Folder
- Bond paper
- Pen





## What Do You Already Know?

**Let us determine how much you already know about the safe keep and proper disposal of tools, materials and outfits. Take this test.**

### Pretest LO 2

Choose the letter of the correct answer. Answer this in your test notebook.

1. Tools and equipment must be cleaned after use in order to:
  - a. Prevent them from rust.
  - b. Prolong their usefulness
  - c. Save capital cost
  - d. All of the above
  
2. The most practical way of preventing rust on tools and equipment is:
  - a. Keeping them in dry place
  - b. Keeping them in open place
  - c. Keeping them in damp place
  - d. Placing them in the corner
  
3. Which of the following statements involves preventive maintenance?
  - a. Leave tools unattended
  - b. Wipe tools before using them
  - c. Store tools inside the room
  - d. Keep tools in clean dry place
  
4. Which of the following is a good tips in storing tools, materials and equipment?
  - a. Clean tools, materials, and equipment immediately.
  - b. Leave tools unattended.
  - c. Store them in a clean dry place.
  - d. Remove dirt attached to them.
  
5. Tools and equipment are best place in:

a. Health corner	c. Dining room
b. Comport room	d. Storeroom
  
6. Improper disposal of waste can lead to \_\_\_\_\_.
  - a. Safe working area
  - b. Healthy environment
  - c. Destruction of soil and surface water
  - d. Proper protection of natural resources
  
7. Which is not considered hazardous waste?

a. Solid waste	c. Corrosive waste
b. Ignitable waste	d. Reactive waste

8. How will you identify hazardous waste?
  - a. Talk to product suppliers and manufacturers.
  - b. Read product labels.
  - c. Ask for Material's Safety Data Sheet (MSDS).
  - d. all of the above
  
9. Tools unattended may lead to.
  - a. Accident
  - b. Loss
  - c. Rust
  - d. All of the above
  
10. Farm tools and equipment should always be taken care of \_\_\_\_\_.
  - a. Longer use
  - b. Rust prevention
  - c. Saving maintenance and capital cost
  - d. All of the above



## What Do You Need To Know?

Read the Information Sheet 2.1 very well then find out how much you can remember and how much you learned by doing Self-check 2.1.

Information Sheet 2.1

### Safe keep of tools, materials and outfits

#### Cleaning of tools and equipment

1. Tools and equipment are cleaned immediately after use in line with farm procedures.
2. Wipe off any oil or grease on the floor.
3. Keep tools clean by brushing off any dust and wiping off excess oil.
4. Wash them thoroughly to remove dirt.
5. Wash working clothes separately from domestic clothing, or use disposable clothing.

#### Materials storage

Safe and efficient materials storage depends on good cooperation and coordination between everyone involved : client, contractors, suppliers and the construction trades.

Top tips for materials storage on smaller projects:

- **Storage areas** - designate storage areas for plant, materials, waste, flammable substances e.g. foam plastics, flammable liquids and gases such as propane and hazardous substances e.g. pesticides and timber treatment chemicals
- **Pedestrian routes** – do not allow storage to ‘spread’ in an uncontrolled manner on to footpaths and other walkways. Do not store materials where they obstruct access routes or where they could interfere with emergency escape
- **Flammable materials** - will usually need to be stored away from other materials and protected from accidental ignition
- **Storage at height** - if materials are stored at height e.g. on top of a container, make sure necessary guard rails are in place if people could fall when stacking or collecting materials or equipment
- **Tidyness** - keep all storage areas tidy, whether in the main compound or on the site itself
- **Deliveries** - plan deliveries to keep the amount of materials on site to a minimum



**Proper storing of tools, materials and pesticide**

### **Safety tips for the storage of tools, materials and outfits**

- Store protective equipment and clothing in a nearby location that provides immediate access but is away from pesticides and their fumes, dusts or possible spills (Figure 1). Provide an immediate supply of clean water and have an eyewash dispenser immediately available for emergencies (Figure 2). Soap and a first aid kit are also necessary.
- Establish procedures to control, contain and clean up spills. Familiarize everyone with the procedures and provide tools and absorbent materials to clean up spills (Figure 3). Prevent pesticide fires. Some pesticides are highly flammable; others do not catch fire easily. The labeling of the pesticides that require extra precautions often will contain a warning statement in the "Physical and Chemical Hazards" section or the "Storage and Disposal" section.
- Install fire detection systems in large storage sites and equip each storage site with a working fire extinguisher that is approved for all types of fires, including chemical fires.
- If you store highly toxic pesticides or large amounts of any pesticides, inform your local fire department, hospital, public health officials and police of the location of your pesticide storage facility before a fire emergency occurs.
- Tell fire department officials what types of pesticides are regularly stored at the site. Give them a floor plan, and work with them to develop an emergency response plan.

**Figure 1**

Store protective equipment and clothing nearby.



**Figure 2**

Have clean water, an eyewash dispenser, soap and a first aid kit available for emergencies.



**Figure 3** Provide spill control station



### Proper waste disposal and management

There is other legislation governing the proper disposal of waste, ranging from low risk waste through to hazardous waste. These laws are enforced by the Environment agency and local authorities.

However, all waste produced can also present a real safety hazard to workers on site if it is not properly managed throughout the project. You need to decide at an early stage:

- **How** - wastes streams produced during building work will be managed in a timely and effective way; and
- **Who** - is responsible for collecting and disposal of specific wastes produced on site. Problems often arise when company and individual duties are not made clear before work starts.

Top tips for waste management on smaller projects:

- **Flammable materials** - make sure that all flammable waste materials (such as packaging and timber off cuts) are cleared away regularly to reduce fire risks;
- **Work areas** - make clearing waste a priority for all trades. Check that everyone is aware of what is required that it is being done;
- **Skips** - waste materials need storing safely before their removal from the site so make sure that you allow sufficient space for waste skips and bins etc. Plan where the skips can be positioned and how often they will need to be collected;

- **Waste within buildings** - consider waste generated inside the building and whether you need to provide wheeled bins or chutes etc. to enable it to be brought out of the building safely;

### Proper disposal of waste

Proper disposal of waste is an important role of the responsible user. Improper disposal can lead to destruction of soil and surface water. Everyone must know how to dispose waste properly.

### Hazardous Wastes

Hazardous wastes are regulated by the Federal Resource Conservation and Recovery Act (RCRA). They are listed in a section of federal regulation. A waste is hazardous if it has one of these characteristics:

1. **Ignitable:** substances that are flammable or spontaneously combustible. It they have and flash point of less than 140 °F or alcohol content of 24% or more.
2. **Corrosive:** wastes that can burn skin or corrodes metal. Liquid with a pH of 2 or lower or 12.5 or higher.
3. **Toxic:** wastes that contain certain heavy metals above specific concentrations.
4. **Reactive:** wastes that are unstable and may explode or react violently with other materials.

### How to identify hazardous waste?

- Talk to product suppliers and manufacturers.
- Read product labels – this should be done before purchasing any pesticides.
- Ask for the Materials' Safety Data Sheet (MSDS) before ordering new pesticides-chemicals.

### How to Manage Hazardous Waste?

Determine how much waste your facility generates per month. The rules depend on how much is generated, how much is stored, and how long it is stored.

#### 1. Containers

- Maintain containers in good condition. Prevent leaks, ruptures and accumulation of rain water on tops of drums.
- Keep containers closed.
- Waste must be compatible with the container.
- Never place wastes that are reactive in the same container.
- If a container leaks, transfer waste to a new container.

#### 2. Storage

- Maintain adequate space between container rows to allow easy inspection for leaks, breaks, or damage.

- Store ignitable or reactive waste at least 50 feet from property boundaries.

### 3. Label

- The waste container should be clearly labeled as:

#### HAZARDOUS WASTE!

- Include the date when waste was first put into the container
- Include federal waste code number
- If the waste the waste is not hazardous, label as such; but regardless; container should state what type of waste is in the container.

### **Proper ways of disposal**

Waste disposal is a growing problem in the modern world. Whether it's the hazards of toxic waste or the sheer volume of regular household waste, the castoffs of industrial society are becoming increasingly intrusive. Solutions do exist, and range from responsible disposal to recycling to avoiding buying unneeded items in the first place.

#### **1. Reducing**

- According to the Environmental Protection Agency (EPA), a large percentage of the waste stream in the United States is made up of materials that could be recycled or reused. Public education programs aimed at getting people used to the idea of recycling have been quite successful, but the idea of reducing consumption has still not taken hold in the public imagination. Many people begin thinking about the problem of waste when they are confronted with something they identify as "trash," rather when they are first confronted with the decision of whether to buy something or not. In order to reduce the waste stream at its source, society needs to avoid producing things, rather than continuing to produce them and then wondering what to do with them.

#### **Reusing**

- Prior to the disposable age which began after World War II with the widespread introduction of plastics, reuse was a common and unquestioned event. Many items were more durably made than they are today, and it only made sense to get maximum use out of them by, for example, handing down clothes from sibling to sibling, reusing food containers for storage, or saving lumber from old construction and using it for something else. Every time something is diverted from the waste stream by being used for something else, it not only decreases the waste stream, it also decreases the pressure that is placed on natural resources through the manufacture of new items.

#### **Recycling**

- Municipal recycling programs have been put into place in many places throughout North America, Europe and elsewhere. Recycling differs from reuse because individual objects are not reused. Rather, their constituent material, usually plastic, metal or glass, is repurposed into new objects. Therefore, although recycling is certainly preferable to sending trash to a landfill and buying new things, it is still energy intensive in the same way as new production, and conserves fewer resources than reuse does.

### ***Electronic waste***

- The problem of electronic waste is a relatively new waste problem and as such has fewer developed solutions in place. Many electronic commodities are thrown out, not because they are broken but because their owners consider them obsolete and want the newest thing. Referring to the arrival of digital television, Theresa Stiner of the Iowa Department of Natural Resources suggests avoiding the unnecessary disposal of old televisions through the purchase of a converter box that allows the old television to be compatible with new systems. This is one example of how waste can be reduced through a shift in consciousness, and an acceptance of a different way of doing things.



Proper ways of disposal ([www.google.com](http://www.google.com))





## How Much Have You Learned?

### Self-Check 2.1

I. Write **True** if the statement is correct and **False** if incorrect.

- \_\_\_\_\_ 1. Allow storage to 'spread' in an uncontrolled manner on to footpaths and other walkways
- \_\_\_\_\_ 2. Do not store materials where they obstruct access routes or where they could interfere with emergency escape.
- \_\_\_\_\_ 3. Always keep all storage areas tidy.
- \_\_\_\_\_ 4. Do not store protective equipment and clothing in a nearby location that provides immediate access.
- \_\_\_\_\_ 5. Install fire detection systems in large storage sites.
- \_\_\_\_\_ 6. Wipe off any oil or grease on the floor.
- \_\_\_\_\_ 7. Wash working clothes together with domestic clothing, or use disposable clothing.
- \_\_\_\_\_ 8. Safe and efficient materials storage depends on good cooperation only.
- \_\_\_\_\_ 9. Tools and equipment are cleaned immediately after use in line with farm procedures.
- \_\_\_\_\_ 10. Some pesticides are highly flammable

II. Write **True** if the statement is correct and **False** if incorrect.

- \_\_\_\_\_ 1. Waste disposal is a growing problem in the modern world.
- \_\_\_\_\_ 2. Proper disposal of waste is an important role of the responsible user.
- \_\_\_\_\_ 3. The problem of electronic waste is a relatively primitive waste problem.
- \_\_\_\_\_ 4. Problems often arise when company and individual duties are not made clear before work starts.
- \_\_\_\_\_ 5. Proper disposal can lead to destruction of soil and surface water
- \_\_\_\_\_ 6. Read product labels – this should be done after purchasing any pesticides.
- \_\_\_\_\_ 7. Laws governing proper disposal of waste, are strictly enforced by the environment agency and local authorities.

\_\_\_\_\_ 8. Wastes that contain certain heavy metals above specific concentrations are non-toxic.

\_\_\_\_\_ 9. Public education programs aimed at getting people used to the idea of recycling have been quite successful, but the idea of reducing consumption has still not taken hold in the public imagination.

\_\_\_\_\_ 10. . Diverting something from the waste stream by using it for

**Refer to the Answer Key. What is your score?**



## How Do You Apply What You Have Learned?

### Activity Sheet 2.1

#### **Proper ways of disposing waste**

Procedures:

1. Group yourselves into five (5)
2. Schedule a visit to an aquaculture facility.
3. With the assistance of the personnel incharge, observe and identify the different wastes found in the facility.
4. Take pictures of these wastes materials and chemicals, including the procedures for properly disposing them; include also the procedures in proper cleaning and storing of materials and chemicals.
5. Compile the photos with appropriate label and descriptions. Include also the discussion on the major and basic government laws and regulations on proper wastes disposal.
6. Submit this and be ready for a presentation or questions from your teacher about your project.



## How Well Did You Perform?

**Find out by accomplishing the Performance Criteria Checklist honestly and sincerely. Remember it is your learning at stake!**

### Performance Criteria Checklist for

#### Activity Sheet 2.1

Have the student/s...	YES	NO	N/A
1. observed and took pictures of different waste materials and chemical in an aquaculture facility?			
2. made a compilation of the pictures, including environmental laws and regulations?			
3. been able to explain the following matters upon questioning of teacher?			
a. cleaning, and storing of used tools and outfit in line with farm procedure.			
b. labeling and storing unused materials according to manufacturers' recommendation and farm requirements.			
c. disposing waste materials according to manufacturers', government and farm requirements			
4. submitted the project?			

Student's Name \_\_\_\_\_ Date \_\_\_\_\_

Comments/Suggestions:



**Congratulations! You did a great job!**

## REFERENCES

### LO1

- CBLM, Fish Culture, 2<sup>nd</sup> Year, Lesson I, pages 1-7.
- CVACP, Region 2. Technoguide for Tilapia
- [http: barry – b tripod.com/ppc.html](http://barry-b.tripod.com/ppc.html)
- [www.google.com.ph](http://www.google.com.ph)

### LO 2

- CBLM, Fish Culture, 2<sup>nd</sup> Year, Lesson I, pages 1-7.
- CVACP, Region 2. Technoguide for Tilapia
- [http: barry – b tripod.com/ppc.html](http://barry-b.tripod.com/ppc.html)
- [http://www.ehow.com/list\\_7392347\\_proper-ways-waste-disposal.html](http://www.ehow.com/list_7392347_proper-ways-waste-disposal.html)
- <http://extension.missouri.edu/p/IPM1013>

# Answer Key

## LESSON 1.USING FARM/FISHERY TOOLS AND EQUIPMENT

WHAT DO YOU ALREADY KNOW?	HOW MUCH HAVE YOU LEARNED?
<b>LO1 Select and use farm tools</b>	
	<b>Self-check 1.1</b>
1. a 2. a 3. c 4. b 5. c 6. d 7. a 8. d 9. d 10. b	1. Cutting tools 2. Pliers 3. Wrench 4. Hammer 5. Screwdriver 6. Measuring tools 7. Secchi disk 8. Sickle 9. 10-30 cm 10. Scoop shovel
<b>LO2. Select and operate farm equipment</b>	
	<b>Self-Check 2.1</b>
1. True 2. False 3. False 4. False 5. True 6. True 7. True 8. True 9. True 10. True	A. 5 2 3 1 7 4 6 B. 2 4 1 6 3 5
<b>LO3. Perform preventive maintenance</b>	
	<b>Self-check 3.1</b>
1. F 2. T 3. T 4. F 5. F 6. T 7. F 8. T 9. F 10. T	<b>I.</b> 1. B - Extend the useful life of facilities 2. B - Maintenance Program 3. D - Manufacturer's manuals 4. D - Manpower, materials, methods, machines and money 5. D – All of the above  <b>II.</b> 1. PP 2. PP 3. PP 4. IM 5. PP 6. PP 7. IM

	8. PP 9. PP 10. IM
--	--------------------------

## LESSON 2. PERFORM ESTIMATION AND BASIC CALCULATION

WHAT DO YOU ALREADY KNOW?	HOW MUCH HAVE YOU LEARNED?
<b>LO1. Perform estimation</b>	
	<b>Self-check 1.1</b>
1. B 2. A 3. B 4. B 5. C 6. B 7. C 8. A 9. B 10. A	<p><b>I.Fill in the blanks.</b></p> <p>The worst error a prospective operator can make is to develop an area without <b>1.project cost estimates</b> and <b>2.program of development</b>.</p> <p>In order to estimate the qualities of materials and resources required to complete a work task, there is a need to prepare a <b>3.bill of materials</b> and <b>4.cost estimates</b>.</p> <p>Prices of materials change depending on the <b>5.locality</b> and <b>6.supply</b> of materials.</p> <p><b>7.Time</b> is a very important element to consider in a work activity.</p> <p>To facilitate completion of a certain job, <b>8.work schedule</b> or a program of work should be prepared.</p> <p><b>9.Project programming</b> is a listing of work activities in relation to manpower requirement versus the volume or piece of required at a certain time of development</p> <p>The <b>10.program of work</b> is the basis of the implementation of the project.</p>
	<p><b>II. Problem solving</b></p> <p><b>1. Estimating the quantity of materials and resources needed.</b></p> <p>1. P 2,800            2. P 20            3. 40 pcs.            4. 10 bags            5. 3,800</p> <p><b>2. Program work of activities</b></p> <p>1. 7,500            2. 30,000            3. 15,000</p>

<b>LO2 Perform basic workplace calculations</b>	
	<b>Self-check 2.1</b>
1. B 2. C 3. B 4. B 5. A	1. C      6. A 2. B      7. C 3. A      8. A 4. B      9. B 5. C      10. C

### LESSON 3. DRAW THE LAYOUT PLAN FOR PONDS, TANKS, PENS, AND CAGES

<b>WHAT DO YOU ALREADY KNOW?</b>	<b>HOW MUCH HAVE YOU LEARNED?</b>
<b>LO1 Draw layout plan for ponds</b>	
	<b>Self-check 1.1</b>
1. B 2. A 3. A 4. C 5. A 6. A 7. B 8. A 9. A 10. B	<b>I.</b> 1. Scale 2. Map 3. Sheet name or title 4. Linear 5. Legend 6. Edition note 7. Sheet number 8. Scale 9. Smaller 10. Layout <b>II.</b> 1. Fishpond 2. Nursery pond 3. Rearing pond 4. Conventional layout 5. Progressive layout 6. Modular pond system 7. Diversion pond 8. Parallel type 9. Multiple stock/harvest system 10. Radiating <b>III.</b> 1. Main dike 2. Freeboard 3. Secondary dike 4. Crown 5. Berm 6. Main gate 7. 0.3 – 1 meter 8. Sluice gate 9. Drainage canal 10. Water supply canal
<b>LO2. Draw layout plan for tanks</b>	
	<b>Self-check 2.1</b>
1. A	1. Tank



2. C 3. A 4. D 5. B 6. C 7. C 8. D 9. D 10. C	2. Hatchery 3. Sand filter tank 4. Live food production tank 5. Outlet hole 6. Intake structure 7. Filtration unit 8. Water pumps 9. Water pumps reservoir 10. Blower
<b>LO3. Draw layout plan for pens and cages</b>	
	<b>Self-check 3.1</b>
1. B 2. A 3. D 4. C 5. A 6. A 7. C 8. B 9. B 10. D	1. Fish cage 2. Fish pen 3. Anchor 4. Mesh 5. Framework 6. Knot 7. Mesh size 8. Net 9. Fouling 10. Mooring

#### LESSON 4. APPLY SAFETY MEASURES ON FARM OPERATIONS

<b>WHAT DO YOU ALREADY KNOW?</b>	<b>HOW MUCH HAVE YOU LEARNED?</b>
<b>LO1. Apply appropriate safety measures.</b>	
	<b>Self-check 1.1</b>
1. B 2. C 3. D 4. B 5. A	1. The safety measures to be observed in the different tasks are the following: <ol style="list-style-type: none"> <li>a. <b>Pond draining and drying.</b> Wear a hat and a long sleeve shirt. Over exposure to heat and extreme temperature may result in range of injuries from burns to frostbite.</li> <li>b. <b>Cultivation of pond bottom.</b> Use long sleeve working clothes, hat and hand gloves. For small ponds, a shovel or rake is used in tilling or cultivating the pond bottom just after draining. For large pond, a rotavator is used.</li> <li>c. <b>Levelling.</b> Wear gloves and long sleeve working clothes and hat to prevent fingers from possible injuries and to prevent skin from direct sunlight of the sun. Remove or gather shell of snails in the pond for these may cause incision or puncture to the feet.</li> <li>d. <b>Repairing gates and screens.</b> Broken or damaged slab and pipes</li> </ol>

	<p>must be repaired. In doing so, use proper tools to avoid accident.</p> <p>e. <b>Repairing dikes.</b> Used digging blade in repairing leakage and seepages of pond dikes. Extra care must be observed so that feet will not be wounded.</p> <p>f. <b>Predator control.</b> Keep the dikes' banks clean to control predators such as snakes and frogs. Wear boots, hat and long sleeve clothes in clearing the grass along pond dikes.</p> <p>2. The tools/materials used in tilling or cultivating the small pond bottom just after draining are rake and shovel.</p> <p>3. The important parts of an emergency plan are list of possible emergencies, providing communication system, planning for action, and identifying resources.</p> <p>4. To understand an <i>incident or near-incident</i>, you need to find out:</p> <ul style="list-style-type: none"> <li>• What caused the incident (immediate events leading up to the incident)</li> <li>• What contributed to the incident (such as unsafe activities and conditions)</li> <li>• What are the root causes that set the stage for the incident (such as inadequate safety policies, procedures, or attitudes)</li> <li>• What are the ways to prevent a similar incident</li> <li>• Carefully look at what happened and try to understand why. To do this, you need to consider all potential influencing factors, such as weather, operator training, maintenance, use of equipment and so on. Talk to anyone who saw the incident or was involved in it.</li> </ul> <p>5. Making farm a healthier and safer workplace can be achieved by</p> <ul style="list-style-type: none"> <li>• re-examining workplace hazards</li> <li>• updating supervisor/worker training</li> <li>• changing how supervising is done</li> <li>• reassigning responsibilities for safety</li> <li>• reviewing your workplace inspection procedures and conduct safety inspections differently. Above all else, consider safety and health as an integral</li> </ul>
--	---

	<p>component of your farm business management. Your safety and well-being are crucial to your farming operation.</p> <p><b>II.</b></p> <ol style="list-style-type: none"> <li>1. D</li> <li>2. B</li> <li>3. A</li> <li>4. D</li> <li>5. D</li> </ol> <p><b>III.</b></p> <ol style="list-style-type: none"> <li>1. True</li> <li>2. True</li> <li>3. False</li> <li>4. True</li> <li>5. False</li> <li>6. True</li> <li>7. False</li> <li>8. False</li> <li>9. True</li> <li>10. True</li> </ol>
<b>LO2. Safely keep/dispose tools, materials and outfit</b>	
	<b>Self-check 3.1</b>
<ol style="list-style-type: none"> <li>1. A</li> <li>2. A</li> <li>3. D</li> <li>4. C</li> <li>5. D</li> <li>6. C</li> <li>7. A</li> <li>8. D</li> <li>9. D</li> <li>10. D</li> </ol>	<p><b>I.</b></p> <ol style="list-style-type: none"> <li>1. False</li> <li>2. True</li> <li>3. True</li> <li>4. False</li> <li>5. True</li> <li>6. True</li> <li>7. False</li> <li>8. False</li> <li>9. True</li> <li>10. True</li> </ol> <p><b>II.</b></p> <ol style="list-style-type: none"> <li>1. True</li> <li>2. True</li> <li>3. False</li> <li>4. True</li> <li>5. False</li> <li>6. False</li> <li>7. True</li> <li>8. False</li> <li>9. True</li> <li>10. True</li> </ol>

## *Acknowledgement*

This Learning Module was developed for the Exploratory Courses in Technology and Livelihood Education, Grades 7 and 8 of the K to 12 Curriculum with the assistance of the following persons:

This Learning Module on **AQUACULTURE** was developed by the following personnel:

### **MODULE WRITER**

#### **FERDINAND S. BRAVO**

Principal IV  
Binmaley School of Fisheries  
Binmaley, Pangasinan Region I

### **REVIEWERS**

#### **GIL P. CASUGA**

*Chief TESD Specialist*

#### **BERNADETTE S. AUDIJE**

*Senior TESD Specialist*

#### **Dr. RODERICK AGUIRRE**

*Languages Expert*

#### **PARALUMAN R. GIRON, Ed.D.**

*Chair, Sub-TWG on K to 10*

#### **OFELIA O. FLOJO**

*Retired Assistant Chief, EED, Region IV-A*

#### **AIDA T. GALURA**

*VSA II, ACNTS*

#### **REYNALDO S. DANTES**

*Senior TESD Specialist*

#### **MARIA A. ROQUE**

*Senior TESD Specialist*

#### **VICTORIO N. MEDRANO**

*Principal IV, SPRCNHS*

#### **BRENDA B. CORPUZ, Ph.D.**

*TA for K to 12 Curriculum*

#### **BEATRIZ A. ADRIANO**

*Principal IV, ERVHS*

#### **DOMINGA CAROLINA F. CHAVEZ**

*Principal II, MBHS*

### **DOCUMENTORS / SECRETARIAT**

#### **PRISCILLA E. ONG**

*K to 12 Secretariat*

#### **EMMANUEL V. DIONISIO**

*Head Teacher III, AFGBMTS*

#### **DANTE D. VERMON JR.**

*Teacher I, AFGBMTS*

#### **FREDERICK G. DEL ROSARIO**

*Head Teacher III, BNAHS*

#### **LYMWEL P. LOPEZ**

*Teacher I, AFGBMTS*

#### **CHERLYN F. DE LUNA**

*Teacher I, AFGBMTS*

#### **Dir. IMELDA B. TAGANAS**

*Executive Director, Qualifications Standards Office  
K to 12 Learning Area Team Convenor, TLE/TVE*