



Republic of the Philippines
DEPARTMENT OF EDUCATION



K to 12 Basic Education Curriculum Technology and Livelihood Education Learning Module



CARPENTRY

EXPLORATORY COURSE

Grade 7 and Grade 8

TABLE OF CONTENTS

What Is This Module About ?.....	2
How Do You Use This Module	3
LESSON 1 – Prepare Construction Materials and Tools	4-22
LESSON 2 – Maintain Tools and Equipment	23-38
LESSON 3 – Perform Mensuration and Calculation	39-58
LESSON 4 – Interpret Drawings and Plans	59-75
LESSON 5 – Practice Occupational Health and Safety.....	76-108
Answer Keys.....	109-115
Acknowledgment.....	116



What Is This Module About?

Welcome to the world of **Carpentry!**

This Module is an exploratory course which leads you to **Carpentry** National Certificate Level II (NC II)¹. It covers **5** common competencies that a Grade 7 / Grade 8 Technology and Livelihood Education (TLE) student like you ought to possess, namely:

- 1). prepare Construction Materials and Tools;
- 2). maintain Tools and Equipment;
- 3). perform Mensurations and Calculations;
- 4). interpret Drawings and Plans; and
- 5). practice Occupational Health and Safety Procedures.

These **5** common competencies are covered separately in **5** Lessons. As shown below, each Lesson is directed to the attainment of one or two learning outcomes.

Lesson 1 – **Prepare Construction Materials and Tools**

- LO 1 - Identify materials and tools applicable to a specific construction job
- LO 2 - Request appropriate materials and tools
- LO 3 - Receive and inspect materials

Lesson 2 – **Maintain Tools and Equipment**

- LO 1 - Check conditions of tools and equipment
- LO 2 - Perform basic preventive maintenance
- LO 3 - Store tools and equipment Learning Outcomes

Lesson 3 – **Perform Mensurations and Calculations**

- LO 1 - Select measuring instruments
- LO 2 - Carryout measurement and calculations

Lesson 4 – **Interpret Drawings and Plans**

- LO 1 - Analyze signs, symbols and data
- LO 2 - Interpret technical drawings and plans
- LO 3 - Apply Freehand Sketching

Lesson 5 – **Practice Occupational Health and Safety Procedures**

- LO 1 - Identity hazards and risks
- LO 2 - Evaluate hazards and risks.
- LO 3 - Control hazards and risks.
- LO 4 Maintain occupational health and safety awareness.

¹NATIONAL CERTIFICATE (NC) is a certification issued to individuals who achieved all the required units of competency for a national qualification as defined under the Training Regulations. NCs are aligned to specific levels within the PTQF. (TESDA Board Resolution No. 2004-13, Training Regulations Framework)

NATIONAL CERTIFICATE LEVEL refers to the four (4) qualification levels defined in the Philippine TVET Qualifications Framework (PTQF) where the worker with:

- a. NC I performs a routine and predictable tasks; has little judgment; and, works under supervision;
- b. NC II performs prescribed range of functions involving known routines and procedures; has limited choice and complexity of functions, and has little accountability;

Your success in this exploratory course on **Carpentry** is shown in your ability to perform the performance standards found in each lesson.



How Do You Use This Module?

This Module has 5 Lessons. Each Lesson has the following parts.

- Learning Outcomes
- Performance Standards
- Materials/Resources
- References
- Definition of Terms
- What Do You Already Know?
- What Do You Need to Know?
- How Much Have You Learned?
- How Do You Apply What You Learned?
- How Well Did You Perform?
- How Do You Extend Your Learning?

To get the most from this Module, do the following.

1. Read the Learning Outcome/s and Performance Standards. These tell you what you should know and be able to do at the end of this Module.
2. Find out what you already know by taking the Pretest then check your answer against the Answer Key. If you get 99 to 100% of the items correctly, you may proceed to the next Lesson. This means that you need not go through the Lesson because you already know what it is about. If you failed to get 99 to 100% correctly, go through the Lesson again and review especially those items which you failed to get.
3. Do the required Learning Activities. They begin with one or more Information Sheets. An Information Sheet contains important notes or basic information that you need to know.
After reading the Information Sheet, test yourself on how much you learned by means of the Self-check. Refer to the Answer Key for correction. Do not hesitate to go back to the Information Sheet when you do not get all test items correctly. This will ensure your mastery of basic information.
4. Demonstrate what you learned by doing what the Activity/Operation/Job Sheet directs you to do.
5. Apply what you have learned in another activity or in real life situation.
6. Accomplish the Scoring Rubrics for you to know how well you performed.

Each Lesson also provides you with references and definition of key terms for your guide. They can be of great help. Use them fully.



If you have questions, ask your teacher for assistance.

LESSON 1

Prepare Construction Materials and Tools



LEARNING OUTCOMES:

At the end of this Lesson, you are expected to do the following:

- LO 1. identify materials and tools applicable to a specific construction job;
- LO 2. request appropriate materials and tools; and
- LO 3. receive and inspect materials.



Definition of Terms

Bill – a statement of payment due to goods and services

Damage – a destruction, injury, or harm to a person or thing

Job – a piece of work of a definite extent or character for a set of fee

Material – a stuff upon which a thing is made

Quantity – a number, amount in size

Requisition – act of requiring something to be furnished; a written request for something authorized but not made available automatically

Tool – a simple implement, as a hammer, saw, and spade chisel etc. used in work

Work – something made or accomplished

LEARNING OUTCOME 1

Identify materials and tools applicable to a specific construction job

PERFORMANCE STANDARDS

- Tools and materials are identified as per job requirements.
- Tools are classified according to its function as per job requirements.
- Materials are classified according to its uses to a specific construction project.
- Tools and materials are selected as per job requirement.



Materials / Resources

- Lumber
- Nails
- Screw
- G.I Wire
- Water
- G. I Sheet
- Reinforcement Steel Bar
- Cement



What Do You Already Know?

Pretest LO 1

Let us determine how much you already know about identifying materials and tools applicable to a specific construction job. Take this test.

Directions: Select the best answer for the choices given. Write your answer on your test notebook.

1. Object used as parts or components of projects.
A. Tools
B. Materials
C. Equipment
D. Hardware
2. Implements manipulated by the hand to facilitate carpentry works.
A. Tools
B. Materials
C. Equipment
D. Hardware
3. List 3 familiar carpentry tools in your house.
4. List 3 construction materials used in your house.
5. List 3 hardware used in your house.

Now check your answer using the Answer Key. If you got 90 - 100 % of the items correctly, proceed to the next Learning Outcome. If not, do the next activity/ties again to gain knowledge and skills required for mastery.



What Do You Need To Know?

Read Information Sheet 1.1 very well then find out how much you can remember and how much you learned by doing the Self-check 1.1.

Information Sheet 1.1

TYPES AND USES OF CONSTRUCTION MATERIALS AND TOOLS

This lesson will enable you to identify materials and tools applicable to a specific job in carpentry.

Materials	Uses
Lumber	Construction/Carpentry
Nails	Construction/Carpentry
Screw	Construction/Carpentry
G.I wire	Construction/Carpentry
Cement	Construction/Carpentry
Sand	Construction/Carpentry
Gravel	Construction/Carpentry
Water	Construction/Carpentry
Steel Reinforcement	Construction/Carpentry
G. I Sheet	Construction/Carpentry

Tools	Uses
Saw	Cutting lumber or board
Tri-Square	Testing squareness
Level hose	Testing level
Level bar	Testing level
Hammer	Driving nails
Chisel	Cutting
Plane	Smoothing
Drill bit	Drilling/Boring holes
Oil stone	Sharpening



How Much Have You Learned?

Self-Check 1.1

Directions: Write opposite the given materials and tools their corresponding uses. Do this on your answer sheet.

Materials	Uses
Lumber	
Nails	
Screw	
G.I wire	
Cement	
Sand	
Gravel	
Water	
Steel Reinforcement	
G. I Sheet	

Tools	Uses
Saw	
Square	
Level hose	
Level bar	
Hammer	
Chisel	
Plane	
Drill bit	
Oil stone	



What Do You Need To Know?

Read Information Sheet 1.2 very well then find out how much you can remember and how much you learned by doing the Self-check 1.2.

Information Sheet 1.2

DESCRIPTION OF MATERIALS AND TOOLS

In this lesson you will describe the materials and tools according to their description per job requirement in carpentry.

Materials:

- | | | |
|----------------|---|--|
| Lumber | - | sawn Timber |
| Nails | - | made of metal used for fastening woods |
| Cement | - | a powdered substance which when mixed with water acts as binder of aggregate |
| Sand | - | fine gritty, substance found in the shore and desert |
| Plywood | - | thin cross laminated sheet of wood |
| Gravel | - | coarse aggregate |

Tools:

- | | | |
|-----------------------|---|--|
| Pull-push-rule | - | used for measuring long distances |
| Claw hammer | - | used for driving and pulling out nails |
| Cross-cut-saw | - | tool used for cutting across the grain |
| Ripsaw | - | used for cutting along the grain |
| Plumb-bob | - | used for vertical alignment |
| Try square | - | used to test the squareness of a stock |
| Hack saw | - | fine toothed saw used to cut metals and pipes |
| Level bar | - | tool used in checking vertical and horizontal position |



TRY SQUARE



PULL PUSH RULE



PLUMB BOB



CROSS CUT SAW



BENCH VISE



HACK SAW



ELECTRIC DRILL



AUGER BIT S



SPIRIT LEVEL



CLAW HAMMER



CROW BAR



SCREW DRIVER



SLEDGE HAMMER



C-CLAMP



CEMENT



How Much Have You Learned?

Self-Check 1.2

Directions: Supply what is defined or described. Write your answer on your answer sheet.

- _____ 1. It is a thin cross laminated sheet of wood.
- _____ 2. This is made of metal used for fastening.
- _____ 3. It is a powdered substance mixed with water.
- _____ 4. It is a fine, dry, gritty substance mixed with water.
- _____ 5. It is a sawn timber.
- _____ 6. It is used for measuring long distances.
- _____ 7. It is used for driving and pulling out nails.
- _____ 8. It is a tool used for cutting along the grain.
- _____ 9. It is used for vertical alignment.
- _____ 10. It is a tool used to test the squareness of a stock.

Refer to the Answer Key. What is your score?

LEARNING OUTCOME 2

Request appropriate materials and tools

PERFORMANCE STANDARDS

- Needed materials and tools are listed as per job requirement
- Materials and tools are requested according to the list prepared.
- Requests are done as per company's standard operating procedures (SOP).



Materials / Resources

- **Actual materials**
- **Requisition forms**
- **Ballpen**



What Do You Already Know?

Pretest LO 2

Directions: Fill up the requisition form. Use another sheet for your answer.

Suggested Project: Bulletin Board			DATE	
Balance on Hand Quantity	Requisition Unit	Materials and Description	Unit price	Total

Teacher examines and inspects the output by using the following scoring guide.

Criteria Rating

1. Accuracy	40%
2. Observance of the sequence of steps	30%
3. Readability of Information	20%
4. Neatness of work	<u>10%</u>
	100%

Now check your answer using the Answer Key. If you got 90 - 100 % of the items correctly, proceed to the next Learning Outcome. If not, do the next activity/ties again to gain knowledge and skills required for mastery.



What Do You Need To Know?

Information Sheet 2.1

REQUISITION PROCEDURE

The information that follows will teach you how to accomplish the form in order to acquire materials.

Procedure:

1. State the name of the project and date when you requested for materials.
2. Fill in the classification of the project and its purpose.
3. Write the number of required materials.
4. List the unit of materials to be requisitioned.
5. Enumerate the materials with their description.
6. List the cost per unit and the total cost.
7. Write your name as requisitioner.
8. Secure the approval of authorities concerned.

SAMPLE OF A REQUISITION FORM				
Suggested Project: Bulletin Board			DATE	
Balance on Hand Quantity	Requisition Unit	Materials and Description	Unit price	Total
1	Piece	¾ Plywood		P 700.00
1	Liter	Stain Maple		P110.00
1	Kilo	Finishing nail 1 1/2		P 30.00
1	Foot	Sand Paper		P 50.00
1	Liter	QDE Boysen (Green)		P 150.00
1	Liter	Thinner (Lacquer)		P 80.00
1	Piece	Paint brush 2		P 20.00
				P1040.00

REQUISITIONER _____

SHOP TEACHER _____

SUPPLY OFFICER _____

FLOW CHART IN RECEIVING TOOLS, EQUIPMENT, SUPPLIES, AND MATERIALS IN THE SHOP

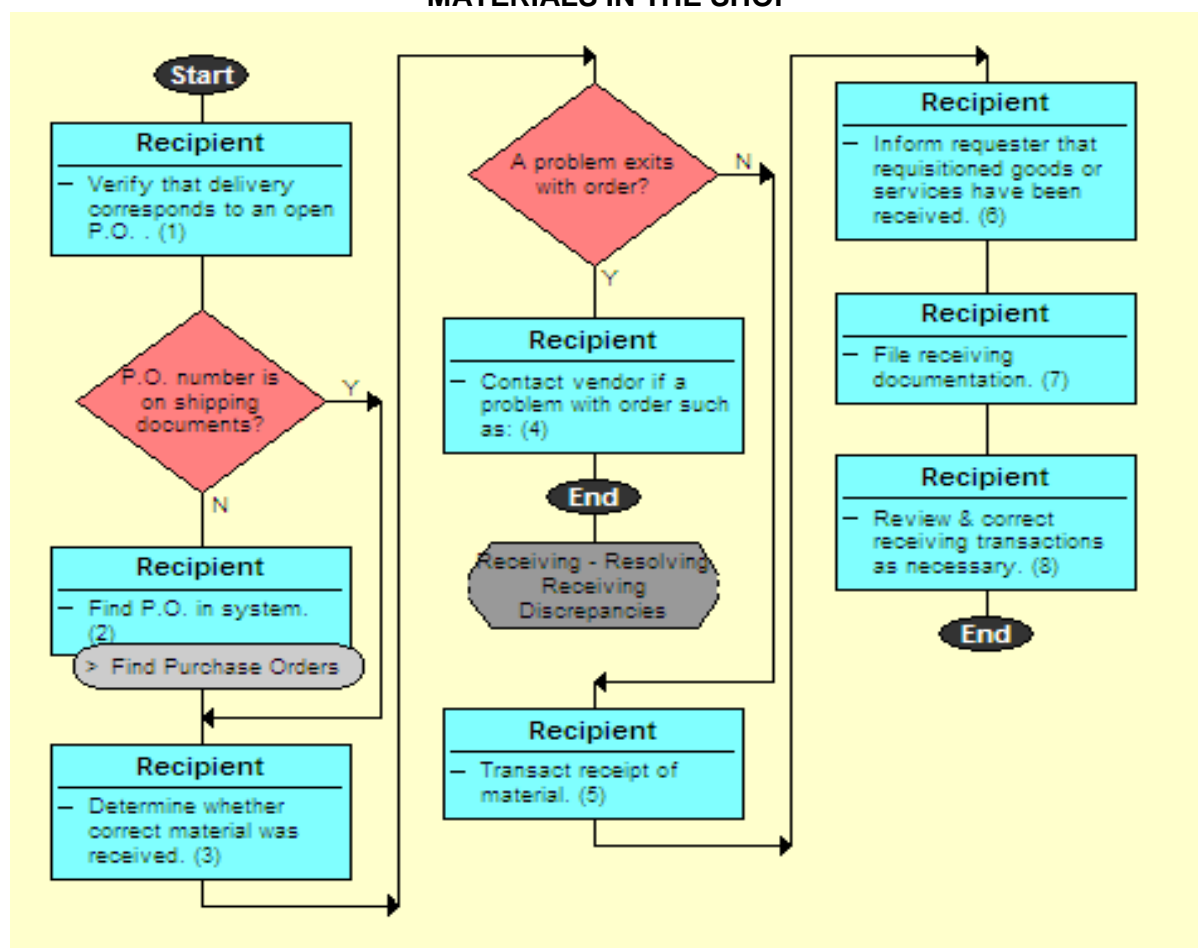

RECEIVING GUIDELINES MATRIX (WEB VERSION)

Merchandise is...	Central Receiving Department / Fiscal Office	Requisitioning Department	Accounts Payable
-------------------	--	---------------------------	------------------

Purpose: The purpose of this matrix is to provide guidance to those personnel involved with receiving or accepting goods and materials on behalf of the Maricopa Community College District. Best business practices support that receiving be completed through a centralized function and location. Such guidance helps ensure that the following “Key Control Objectives” and “Process Attributes” are achieved.

- Goods are purchased only with proper authorization.
 - Goods compared to purchase orders or other purchase authorization before acceptance.
 - Unmatched receivers investigated; Unauthorized items identified for return to vendor.
 - Receipts under blanket purchase orders monitored; Quantities exceeding authorized total returned to vendor.

- Goods received are recorded correctly as to account, amount, and period.
 - Goods counted, inspected and compared to packing slips before acceptance.
 - Receiving reports issued by receiving/ inspection department in pre-numbered order.
 - Receiving documentation, purchase order, and invoice matched before recording liability.

This matrix serves to provide guidelines in which the order of steps completed may vary depending on college and circumstances.

Goods POs/LPOs – Non-Capital

<ul style="list-style-type: none"> • Non-capital and delivered to Central Receiving Department. 	<ul style="list-style-type: none"> • Inspect for proper addressing before acceptance. • Inspect for proper number of packages agrees to delivery document before acceptance. • Inspect for obvious damage before acceptance. • Agree supporting documentation (packing slip/invoice) to existing PO/LPO. • Receive merchandise on-line in CFS. • Deliver merchandise to Requisitioning Department. Obtain signature from Requisitioning Department on original supporting documentation (packing slip/invoice) or Delivery Log Sheet. • Make copy(ies) of signed packing slip/invoice (Central Receiving Department & Requisitioning Department). • If invoice enclosed with shipment, forward original to Accounts Payable. Maintain original packing slip with hard-copy PO/LPO. 	<ul style="list-style-type: none"> • Sign original supporting documentation (packing slip/invoice) or Delivery Log Sheet indicating physical receipt of goods within department. • Inspect merchandise for quality and concealed damage. • Notify vendor and/or Central Receiving Department, as appropriate, of concealed damage, overshipments, or merchandise received but not ordered. 	<ul style="list-style-type: none"> • If invoice received directly from vendor, it is entered into CFS and maintained in A/P Department awaiting on-line receiving. • Pay vendor upon 3-way match of on-line PO, Invoice, and on-line Receiver.
--	--	---	--



How Much Have You Learned?

Self-Check 2.1

Directions: Accomplish the requisition form. Use another sheet for this activity.

Suggested Project: Bulletin Board			DATE	
Balance on Hand Quantity	Requisition Unit	Materials and Description	Unit price	Total

Fig.1. Receiving Procedure in Matrix Form

Teacher examines and inspects the output by using the following scoring guide.

Criteria for Rating

- 1. Accuracy 40%
 - 2. Observance of the sequence of steps 30%
 - 3. Readability of Information 20%
 - 4. Neatness of work 10%
- 100%

Refer to the Answer Key. What is your score?



What Do You Need To Know?

Information Sheet 2.1

REQUESTED MATERIALS AND TOOLS ACCORDING TO THE PREPARED LIST

Bill of Materials

A bill of materials is a list of all things needed in a project together with their description, sizes and amount or price. All information needed should be in the bill of materials.

Parts of a Bill of Materials

1. Quantity tells the amount of materials to be purchased.
2. Unit gives the measure of materials to be purchased.
3. Description states the detailed name of materials.
4. Unit cost gives the price of each material.
5. Amount is the cost of all materials.

Suggested Project: Bulletin Board

Quantity	Unit	Materials and Description	Unit price	Total
1	Piece	¾ Plywood		P 700.00
1	Liter	Stain Maple		P110.00
1	Kilo	Finishing nail 11/2		P 30.00
1	Foot	Sand Paper		P 50.00
1	Liter	QDE Boysen (Green)		P 150.00
1	Liter	Thinner (Lacquer)		P 80.00
1	Piece	Paint brush 2		P 20.00
				P1040.00



How Much Have You Learned?

Self-Check 2.1

Directions: Complete the following bill of materials with the missing information based on the given project. Write your answer on a piece of paper.

Given Project: Bulletin Board

Quantity	Unit	Materials and Description	Unit price	Total
1		$\frac{3}{4}$ Plywood		
1	Liter	Stain Maple		P110.00
		Finishing nail 1 1/2		P
		Sand Paper		P 50.00
		QDE Boysen (Green)		P
	Liter	Thinner (Lacquer)		
1		Paint brush 2		P 20.00

Refer to the Answer Key. What is your score?

LEARNING OUTCOME 3

Receive and inspect materials

PERFORMANCE STANDARDS

- Materials and tools are substituted and provided unavailable without sacrificing cost and quality of work.
- Materials and tools as per quantity and specification based on requisition are received and inspected.
- Tools and materials are checked for damage and manufacturing defects.
- Materials and tools received are handled with appropriate safety devices.
- Materials and tools are set aside to appropriate location nearest to the workplace.



What Do You Need To Know?

Read Information Sheet 3.1 very well then find out how much you can remember and how much you learned by doing Self-check 3.1.

Information Sheet 3.1

ACQUIRE AND INSPECT MATERIALS/TOOLS

It is important to inspect and check materials and tools for defects and damage before receiving them so that you can ask for replacements for those that you found defective.

1. Check if the materials and tools are complete in terms of quantity and specification (number of pieces, length, width, etc.)
2. Check the physical condition of tools, (check tools against the specification, quantity, and quality,) see to it that parts are complete, cutting edges or tooth free from damages,
3. Check the accessories of each material and tool. See to it that nothing is missing.
4. If any of the materials or tools is found missing or defective, report it immediately to the supply officer or teacher.
5. Get a replacement for the materials and tools found defective.
6. Sign the requisition form as you receive materials and tools.

7. Store the received materials and tools in a safe area or store room nearest your workplace. (store materials, in proper order, bulky and heavier materials at the bottom lighter and smaller items on top of the pile)
8. Always handle the materials and tools carefully. (avoid dropping the tools on the floor, do not expose tools and materials on sunlight or rains).



How Much Have You Learned?

Self-Check 3.1

Directions: Check the materials and tools that are being received in the checklist. Put **X** if the materials and tools are not in good condition and check if in good condition.

Tools and Materials	Remarks	
	GOOD	REJECT
1. 1 piece $\frac{3}{4}$ plywood		
2. 1 liter satin maple		
3. 1 kilo finishing #1 $\frac{1}{2}$		
4. 1 foot sand paper		
5. 1 liter qde boysen (green)		
6. 1 liter thinner (lacquer)		
7. 1 piece paint brush		

Prepared by: _____
Inspector

Refer to the Answer Key. What is your score?



Congratulations! You did a great job! Rest and relax a while then move on to the next lesson. Good luck!

REFERENCES

LO1

- *References Tools/Equipment, etc.* - They should conform to the Contextual learning Matrix (Refer to from the conditions of the Competency Based Curriculum)

LO 2

- *References Tools/Equipment, etc.* - They should conform to the Contextual learning Matrix (Refer to from the conditions of the Competency Based Curriculum)

LO 3

- *References Tools/Equipment, etc.* - They should conform to the Contextual learning Matrix (Refer to from the conditions of the Competency Based Curriculum)

LESSON 2

Maintain Tools and Equipment



LEARNING OUTCOMES:

At the end of this Lesson, you are expected to do the following:

- LO 1. check condition of tools and equipment
- LO 2. perform basic preventive maintenance; and
- LO 3. store tools and equipment.



Definition of Terms

Finishing materials – chemical or substance applied in finishing carpentry

Hardware – metal supplies used in furniture

Inventory – the accounting of tools and materials

Label – refers to the indicated name of tools and equipment

Lubricants – oils or grease which is use to help the machine to run smoothly

Mensuration – the act or art of measuring

Perimeter – the bounding line or curve of a plain area

Power tools – handy machines operated by current/electricity

Scaler – marked for use in measurement

Segregate – set aside things from the others

Standard – serves as a measure of reference

Stock – refers to a lumber for a certain carpentry job

Store – to put tools and materials in their proper places

Substrate – wood to be cut in a cutting machine

LEARNING OUTCOME 1

Check Condition of Tools and Equipment

PERFORMANCE STANDARDS

- Tools and equipment are identified according to classification/specification and job requirements.
- Non-functional tools and equipment are segregated and labeled according to classification.
- Safety of tools and equipment are observed in accordance with manufacturer's instructions.
- Conditions of PPE are checked in accordance with manufacturer's instructions.



Materials / Resources

- **Lubricants**
- **Paint Brush**
- **Cloth**
- **Smooth Sand Paper**
- **Kerosene**



What Do You Already Know?

Let us determine how much you already know about checking condition of tools and equipment. Take this test.

Pretest LO 1

- A. Classify the different types of tools and materials.
1. Claw hammer
 2. Bar Clamp
 3. Spoke Shave
 4. Steel Square
 5. Back Saw
 6. Pull Push Rule
 7. Compass
 8. Triangular File
 9. Varnish
 10. Hinge
- B. Identify the different tools and materials that are described in each item.
1. Tool used for smoothing curve surfaces.
 3. Tool used for drawing arcs and circles.
 4. Tool used for testing the squareness of large stocks.
 6. Tool used to hold bits when boring.
 7. Materials used to lubricate movable parts.
 9. Tool used to cut stock along the grain.
 10. Tool used for sharpening saws.

Now check your answer using the Answer Key. If you got 90 - 100 % of the items correctly, proceed to the next Learning Outcome. If not, do the next activity/ties again to gain knowledge and skills required for mastery.



What Do You Need To Know?

Read Information Sheet 1.1 very well then find out how much you can remember and how much you learned by doing the Self-check 1.1.

Information Sheet 1.1

CHECK CONDITION OF TOOLS AND EQUIPMENT

CLASSIFICATION OF HANDTOOLS

A. Measuring tools

1. **Pull-Push Rule** - flexible tape that slides into a material case and it is used to measure irregular and regular shapes.
2. **Ruler** - 12-inch or one foot rule and it is used to take/make simple measurements.
3. **Meter Stick** - used to measure a work piece.
4. **Try Square** - squaring, measuring and testing tool used to check adjacent surfaces for squareness.
5. **Caliper** - used to transfer measurements from the rule to the work.

B. MARKING LINING TOOLS

1. **Pencil** - used to layout or mark cutting lines.
2. **Marking Gauge** - wood or metal tool consisting of a beam, head and a point used to mark a line parallel to the grain of the wood.
3. **Chalk Line** - used to establish a straight line on a surface.
4. **Divider** - tool with two metal legs used to lay-out an arc circle or step off division on a line.
5. **Compass** - used to scribe arcs and circle in a metal wood.

C. TESTING TOOLS

1. **Try Square** - tool used in squaring, measuring and testing the squareness of a wood.
2. **Steel Square** - framing square used to mark out the work for squaring and checking of angles and is used in the construction of roof framing and large furniture.
3. **Spirit Level** - tool used for testing vertical and horizontal surfaces.
4. **Plumb bob** - tool used to test the vertical and horizontal surfaces.

D. EDGE CUTTING TOOLS

1. **Chisel** - tool used to trim and shape wood.
2. **Plane** - used to obtain a smooth and flat surface.
3. **Spoke shave** - small plane like tool from irregularly shaped objects.
4. **Cabinet scraper** - rectangular piece of steel with two cutting edges used for working flat and curved shapes.

E. TOOTH-CUTTING TOOLS

1. **Cross Cut Saw** - handsaw used to cut the wood across the grain.
2. **Rip-saw** - hand saw used to cut the wood along the grain.
3. **Back Saw** - handsaw with a metal back and plywood and joinery.
4. **Compass Saw** - used to cut irregular shape either in large or small board.
5. **Turning Saw** - used to rip, cross and cut curves in lumber.
6. **Coping Saw** - u-shaped saw used for cutting irregular shape in small board.
7. **Dovetail Saw** - small back saw with a straight chisel type handle used to cut very fine joints.

F. BORING TOOLS

1. **Auger bit** - tool used to make hole in woods.
2. **Expansive bit** - tool used to drill holes of various sizes in woods.
3. **Drill Bit** - tool used for boring holes either in metals, woods or plastics.

G. HOLDING TOOLS

1. **C-Clamp** - used for holding together pieces of lumber while working.
2. **Bench Vice** - used to hold any materials or tools in place.

3. **Bar Clamp** - used to hold large boards or frames together while assembling or gluing.

H. MISCELLANEOUS TOOLS

1. **Oil Stone** - used for sharpening edge cutting tools such as chisel.
2. **Files** - used to smoothen metal and wood surfaces.
3. **Paint Brush** - used to apply paint or varnish on wood surfaces
4. **Nail Set** - used to drive the head of nails lower than surface of wood.
5. **Saw Set** - used to bend the upper half of each tooth to one side or the other to form a set.

I. PORTABLE POWERTOOLS

1. **Sander** - portable power tool used for sanding furniture pieces.
2. **Router** - used for shaping surfaces and edges of furniture parts.
3. **Jigsaw** - power tool used primarily for cutting curved or irregular shapes of wood surfaces.
4. **Circular saw** - power saw used for many types of cutting, particularly on large panel stock.
5. **Electric Drill** - power drill which is used to drill holes in various materials to perform a multitude of tasks.

J. PPE (Personal Protective Equipment)

1. **Goggles** - used to protect the eyes against flying debris and harmful liquids.
2. **Ear Protector** - used to protect the ears against high frequency noise.
3. **Face Mask** - used to prevent the inhalation of sprayed paint fumes.
4. **Gloves** - used to protect the hands while working.
5. **Apron** - used to protect the worker against flying debris.

K. DRIVING TOOLS

1. **Claw Hammer** - used to drive and pull out nails on wooden surfaces.
2. **Mallet** - made out of wood or rubber used to drive other tools like chisel.
3. **Nail Set** - used in setting the head of a finishing nail below the surface of the wood.
4. **Screw Driver** - used to drive and loose screws.



How Much Have You Learned?

Self-Check 1.1

- A.** Classify the different types of tools.
1. Claw hammer
 2. Bar Clamp
 3. Spoke Shave
 4. Steel Square
 5. Back Saw
 6. Pull Push Rule
 7. Compass
 8. Triangular File
 9. Varnish
 10. Hinge
- B.** Identify the different tools that are described in each item.
1. Tool used for smoothing curve surfaces.
 2. Finishing materials used to seal the pores of wood.
 3. Tool used for drawing arcs and circles.
 4. Tool used for testing the squareness of large stocks.
 5. Tool used to hold bits when boring.
 6. Finishing material which makes wood shiny.
 7. Tool used to cut stock along the grain.
 8. Tool used for sharpening saws.

Refer to the Answer Key. What is your score?



How Do You Apply What You Have

Show that you learned something by doing this activity.

Operation Sheet 1.1

Procedure in segregating and Labeling Non-functional Tools and Equipment

1. Conduct an inventory of tools and equipment.
2. Record the number of non-functional tools and equipment.
3. Segregate tools that are serviceable or unserviceable.
4. Report the number of tools and equipment that are non-functional but subject for repair.
5. Label tools and equipment which are condemnable.
6. Return tools and equipment in the tool cabinet as per operating procedures.

Operation Sheet 1.2

Procedure in Checking Condition of Personal Protective Equipment

1. Inspect any damaged or defective Personal Protective Equipment (PPE).
2. Test the functionality of each PPE.
3. Separate the non-functional and functional PPE.
4. Repair/replace the non-functional PPE.
5. Report the condition or status of PPE.



How Well Did You Perform?

Find out by accomplishing the Scoring Rubric honestly and sincerely. Remember it is your learning at stake!

Teacher's Checklist

Procedure in segregating and Labeling Non-functional Tools and Equipment

	Performed	Not Performed
1. Conducted inventory of tools and equipment		
2. Recorded non-functional tools and equipment		
3. Segregated non-functional tools and equipment		
4. Reported non-functional tools and equipment		
5. Labeled condemnable tools and equipment		
6. Returned tools and equipment in the cabinet.		

Scoring Rubric

Steps Performed

Weight

6- Very Satisfactory

5- Satisfactory

4- Needs Improvement

3-Failed

Procedure in Checking Condition of Personal Protective Equipment

Directions: Perform the following steps in checking the Personal Protective Equipment (PPE).

	Performed	Not Performed
1. Inspected any damaged or defects of the Personal Protective Equipment (PPE).		
2. Tested the functionality of each Personal Protective Equipment (PPE).		
3. Separated the non-functional and functional Personal Protective Equipment (PPE).		
4. Repaired/replaced the non-functional Personal Protective Equipment (PPE).		
5. Reported the condition or status of Personal Protective Equipment (PPE).		

Scoring Rubric

Steps Performed

Weight

6- Very Satisfactory

5- Satisfactory

4- Needs Improvement

3-Failed

LEARNING OUTCOME 2

Perform basic preventive maintenance

PERFORMANCE STANDARDS

- Lubricants are identified according to types of equipment.
- Tools and equipment are lubricated according to preventive maintenance schedule or manufacturer's specification.
- Measuring instruments are checked and calibrated in accordance with manufacturer's instructions.
- Tools are cleaned and lubricated according to standard procedures.
- Defective equipment and tools are inspected and replaced according to manufacturer's specification
- Workplace is cleaned and kept in safe state in line with OSHC regulations



What Do You Need To Know?

Read the Information Sheet 2.1 very well then find out how much you can remember and how much you learned by doing the Self-check 2.1.

Information Sheet 2.1

LUBRICATING TOOLS AND EQUIPMENT

1. Read and analyze the use of preventive Maintenance Schedule form.
2. Determine the types of tools and machine needed to be lubricated.
3. Fill out a requisition slip form in releasing the lubricants needed.
4. Secure a borrower's slip from your teacher.
5. Fill out the slip form correctly intended for the needed tools.
6. Perform the task according to the prescribed schedule and the assigned machine.
7. Perform lubricating procedure.
8. Determine the parts of the machine needed to be lubricated.
9. Apply thin coat of oil on the parts for a long period of time.
10. Open the bearing cover and apply grease.
11. Apply grease on sealed bearing with the use of a grease gun.



How Much Have You Learned?

Self-Check 2.1

Directions: Copy the table on a separate sheet of paper then check the appropriate box whether you performed each indicator.

INDICATORS	YES	NO
1. Utilized the Preventive Maintenance Schedule.		
2. Determined the types of tools and machine needed to be lubricated.		
3. Filled out the requisition slip form in releasing the lubricants needed.		
4. Secured the borrower's slip from your teacher?		
5. Filled out the slip form correctly intended for the needed tools.		
6. Performed the task according to the prescribed schedule and the assigned machine.		
7. Performed the lubricating procedures.		
8. Determined the parts of the machine needed to be lubricated.		
9. Applied the thin coat of oil on the parts that are used for a long period of time.		
10. Applied the grease on sealed bearing with the use of a grease gun.		

Self-Check 2.2

Directions: Copy the table on a separate sheet of paper then check the appropriate box whether you performed each indicator.

Indicators	Yes	No
1. Secured the inspection report from the teacher.		
2. Determined defective instruments.		
3. Inspected the defective tools.		
4. Replaced the defective tools.		
5. Used the Repair manual as guide in replacing defects.		

Self-Check 2.3

Directions: Copy the table on a separate sheet of paper then check the appropriate box whether you performed each indicator.

Indicators	Yes	No
1. Secured the inspection report from the teacher.		
2. Determined defective instruments.		
3. Inspected the defective tools inspected.		
4. Replaced the defective tools.		
5. Used the Repair manual as guide in replacing defects.		

Refer to the Answer Key. What is your score?



How Do You Apply What You Have Learned?

Show that you learned something by doing this activity.

Operation Sheet 2.1

Steps in Filling Out Inspection Report Form

Directions: Do the following procedure.

1. Secure an inspection report form from your teacher.
2. Determine the defective instrument based on the report form.
3. Replace inspected tool and equipment defects based on the report form.
4. Use the Repair Manual in replacing the defective parts.



How Well Did You Perform?

Find out by accomplishing the Scoring Rubric honestly and sincerely.
Remember it is your learning at stake!

SCORING GUIDE

7-8	Very Satisfactory
5-6	Satisfactory
4-3	Fair
1-2	Failed



How Do You Extend Your Learning?

Assignment Sheet 2.1

Directions: Practice regular maintenance of tools and equipment in the shop and at home using the required inspection report.



Congratulations! You did a great job! Rest and relax a while then move on to the next lesson. Good luck!

REFERENCES

LO1

- *References Tools/Equipment, etc.* - They should conform to the Contextual learning Matrix (Refer to from the conditions of the Competency Based Curriculum)

LO 2

- *References Tools/Equipment, etc.* - They should conform to the Contextual learning Matrix (Refer to from the conditions of the Competency Based Curriculum)

LESSON 3

Perform Mensuration and Calculation

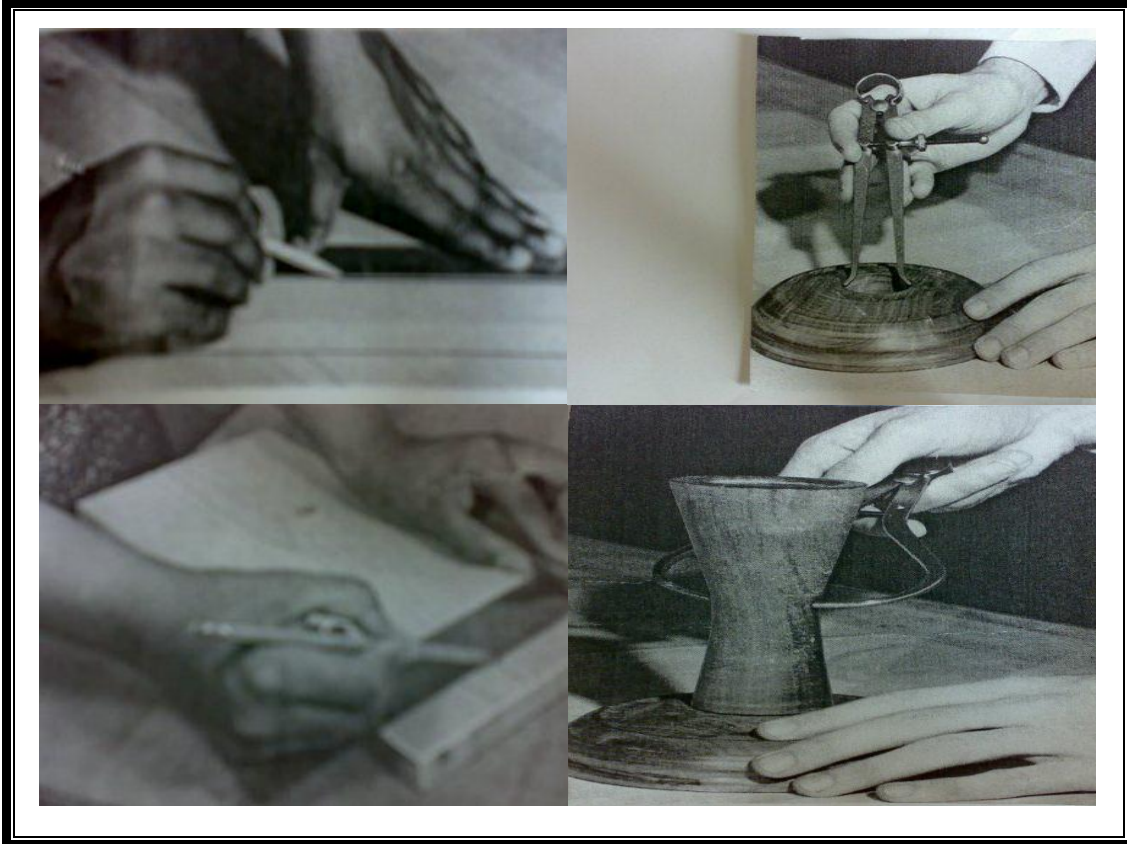

LEARNING OUTCOMES:

At the end of this Lesson, you are expected to do the following:

- LO 1. select measuring instruments; and
- LO 2. carry out measurement and calculations.



Definition of Terms

Area – extent of part of a surface enclosed within a boundary

Calculation – the act or process of or result of calculating

Circumference – distance around the circle

Classification – group or category within an organized system

Decimal – number expressed in a counting system that uses units of 10, especially a decimal fraction

Dimension – measurable extent such as length, thickness and width

Fraction – number expressed as a quotient of two other numbers

Fraction – number expressed as a quotient of two other numbers

Geometric Shapes – characterized by straight line, regular curves and angles

Graduation – scale of a measuring tool

Mensuration – act or art of measuring

Perimeter – bounding line or curve of a plain area

Standard – serves as a measure of reference

Stock – refers to a lumber for a certain furniture job

Substrate – wood to be cut in a cutting machine

Volume – space inside a solid figure

LEARNING OUTCOME 1

Select measuring instruments

PERFORMANCE STANDARDS

- Measuring tools are selected/identified as per object to be measured or job requirements.
- Correct specifications are obtained from relevant sources.
- Measuring instruments are selected according to job requirements.
- Alternative measuring tools are used without sacrificing cost and quality of work.
- Measurements are obtained according to job requirements



Materials / Resources

- Actual Objects to be measured
- Actual Measuring Tools



What Do You Already Know?

Pretest LO 1

Let us determine how much you already know about selecting measuring instruments. Take this test.

Directions: Identify the different measuring tools



1.



2.

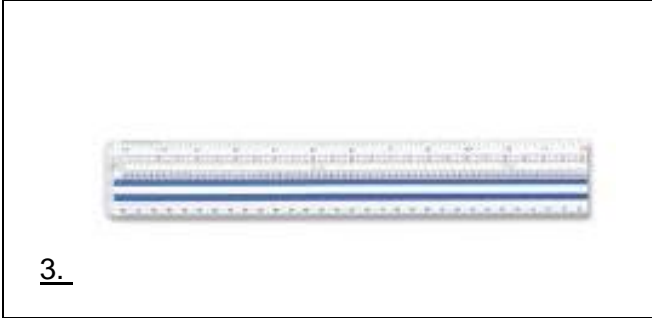

3.



4.

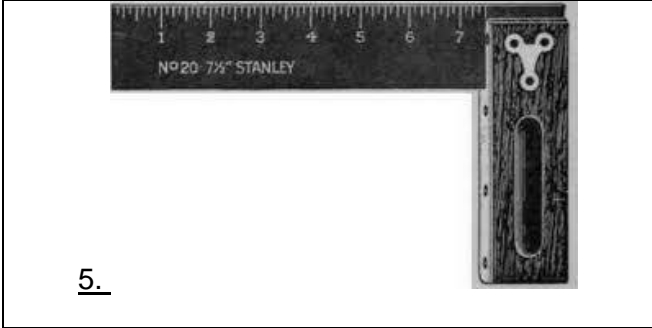

5.

Now check your answer using the Answer Key. If you got 90 - 100 % of the items correctly, proceed to the next Learning Outcome. If not, do the next activity/ties again to gain knowledge and skills required for mastery.







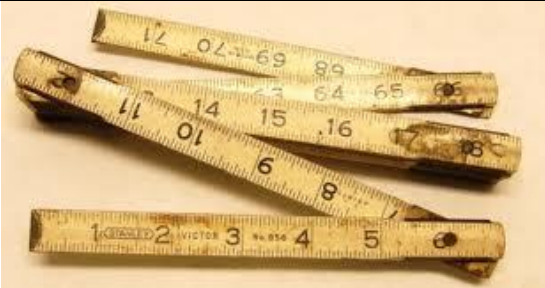

What Do You Need To Know?

Read Information Sheet 1.1 very well then find out how much you can remember and how much you learned by doing the Self-check 1.1.

Information Sheet 1.1

TYPES OF MEASURING TOOLS

<p>1. Pull-push rule – used for measuring long pieces of stock.</p>	
<p>2. Zig Zag Rule – a folded measuring tool.</p>	
<p>3. Ruler – used for measuring short pieces of stock.</p>	

<p>4. Caliper – used for measuring diameter.</p>	
<p>5. Try Square – used for checking flatness and squareness.</p>	
<p>6. Meter Stick – a measuring device which is one (1) meter in length.</p>	
<p>7. Divider – used for dividing distances.</p>	
<p>8. Compass – used for scribing arcs and circles.</p>	

9. **Protractor** – used for laying out angles.

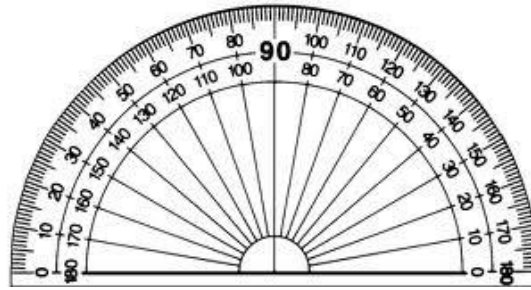

HANDLING OF MEASURING INSTRUMENTS / TOOLS

A. DO'S

1. Wipe measuring tools/instruments before returning them to the storage room.
2. Oil the movable parts of the measuring tools such as zigzag rules, calipers, dividers and compasses to avoid stock-up.
3. Make sure that grits like sand do not get inside the housing or case of a pull-push rule to avoid wearing off of the graduations.
4. Check the lock of a pull-push rule if it is working.

B. DON'T'S

1. Do not wipe off edges of the steel tape of pull-push rule with bare hands to avoid injury.
2. Do not pull the steel tape of pull-push rule too much to avoid the coil spring from damage.
3. Do not use the caliper as tongs.

LINEAR MEASUREMENTS FOR THE 6 FACES OF LUMBER

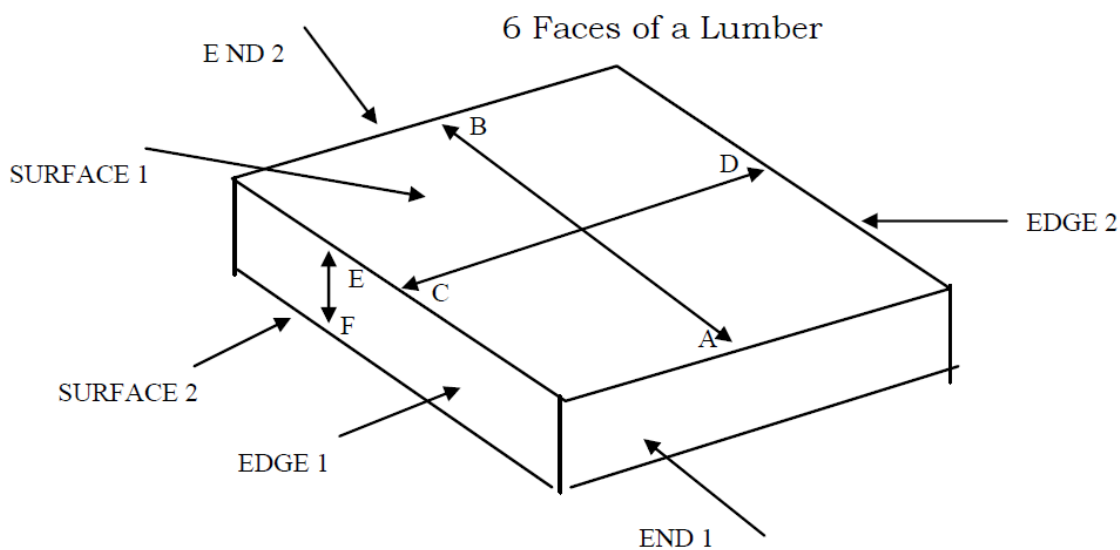

A lumber has 6 faces: 2 ends, 2 edges and 2 surfaces

Hence; the linear measurements obtained are:



1. End 1 to end 2 or A B = Length (L)



2. Edge 1 to Edge 2 or C D = Width (W)



3. Surface 1 to surface 2 or E F = Thickness / Height (T / H)



How Much Have You Learned?

Self-Check 1.1

- I. List down nine measuring tools on your quiz notebook.

1. _____
2. _____
3. _____
4. _____
5. _____
6. _____
7. _____
8. _____
9. _____

- II. List down some DO's and DON'T's in handling measuring instrument/ tools

A. DO'S

- 1.
- 2.
- 3.
- 4.

B. DON'T'S

- 1.
- 2.
- 3.

III. Enumerate the 6 faces of a lumber and the 3 linear measurements obtained.

A. 6 Faces of A lumber

- 1.
- 2.
- 3.
- 4.
- 5.
- 6.

B. 3 Linear measurements obtain from the 6 faces of a lumber

- 1.
- 2.
- 3.

Refer to the Answer Key. What is your score?

LEARNING OUTCOME 2

Carry out measurement and calculations

PERFORMANCE STANDARDS

- Accurate measurements are obtained according to job requirements.
- Work pieces are measured according to job requirements



Materials / Resources

- Actual Objects to be measured
- Measuring tools
- Record Book
- Pencil



What Do You Already Know?

Let us determine how much you already know about carrying out measurement and calculations. Take this test.

Pretest LO 2

Directions: Enumerate the following

- 1-2 – What are the 2 systems of measurements?
- 3-5 - Give at least 3 units of linear measurements in the English system.
- 6-9 – Give at least 3 units of linear measurements in the Metric System.

Now check your answer using the Answer Key. If you got 90 - 100 % of the items correctly, proceed to the next Learning Outcome. If not, do the next activity/ties again to gain knowledge and skills required for mastery.



What Do You Need To Know?

Show that you learned something by doing this activity.

Information Sheet 2.1

SYSTEM OF MEASUREMENTS

The two (2) systems of measurements are: the English and the Metric System. The English system originated in England also known as the U.S. customary system of measurement while the Metric System was developed in France and also known as the S. I. (International Standard).

I. (UNIT OF MEASURES) - LINEAR MEASUREMENT

ENGLISH

Yard (yd)

Foot (ft) / („)

Inch (in.) / (“)

METRIC

meter

decimeter 1/10 meter

centimeter 1/ 100 meter

millimeter 1 /1000 meter

II. READING OF MEASUREMENTS

A. Reading the inch

The inch is divided into segments called graduations. Each graduation represents a measurement in form of a proper fraction. The inch can be divided into 16, 8, 4 and 2, equal parts.

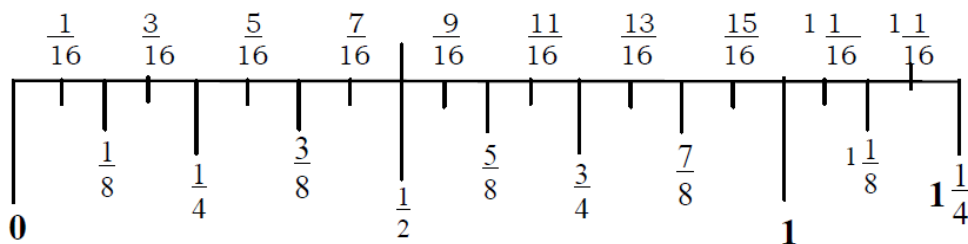

Note: The illustration is not the actual length of an inch.

B. Reading the centimeter and millimeter

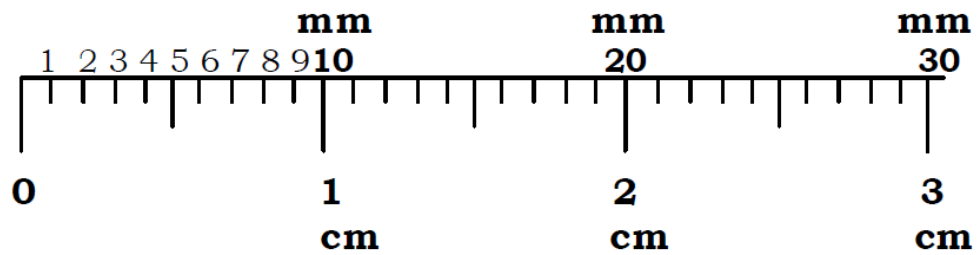

III. CONVERTING FRACTION TO DECIMAL

In converting fractions to decimals, divide the numerator by its denominator whether it is proper, improper or mixed fraction.

Sample Solutions:

A. Proper fraction

$$2/5 = 0.4$$

$$\begin{array}{r} 0.4 \\ 5 \overline{) 2.0} \\ \underline{0} \\ 20 \\ \underline{20} \\ 0 \end{array}$$

B. Improper fraction

$$11/3 = 3.66$$

$$\begin{array}{r} 3.66 \\ 3 \overline{) 11.00} \\ \underline{9} \\ 20 \\ \underline{18} \\ 20 \\ \underline{18} \\ 2 \end{array}$$

C. Mixed fraction

$$2 \frac{1}{2} = 2.5$$

$$\begin{array}{r} 0.5 \\ 2 \ 2 \overline{) 1.0} \\ \underline{1.0} \\ 0 \end{array}$$

IV. CONVERTING UNITS OF MEASURE

GUIDE TABLE IN UNIT CONVERSION

English	to	English	1foot	=	12 inches
Metric	to	Metric	1 meter	=	10 decimeter
			1 dm	=	10 centimeter
English	to	Metric	1 inch	=	2.54 cm
			1 inch	=	25.4 mm
			1 foot	=	30.48 cm
Metric	to	English	1 meter	=	3.28 feet
			1 meter	=	39.37 inches

Sample Solutions in Conversion

A. Foot to inches

$$3 \text{ ft} = \underline{\hspace{2cm}} \text{ inches}$$

Solution: Multiply 3ft by 12 inches / ft = 36 inches

B. Inch to feet

$$48 \text{ inches} = \underline{\hspace{2cm}} \text{ Feet}$$

Solution: Divide 48 inches by 12 inches / feet = 4feet

C. Centimeter to millimeter

$$22 \text{ cm} = \underline{\hspace{2cm}} \text{ millimeters}$$

Solution: Multiply 22 cm by 10 mm / cm = 220mm

D. Inch to centimeter

$$6 \text{ inches} = \underline{\hspace{2cm}} \text{ centimeter}$$

Solution: Multiply 6 inches by 2.54 cm / inch = 15.24 cm

V. TAKING DIMENSIONS

Ways of taking dimension

- 1 Measure end to end of stock with a tool



- 2 Measure edge to edge with a tool



- 3 Measure outside diameter of a cylindrical object using a caliper



- 4 Measure inside diameter with a caliper



- 5 Lay-out width



CALCULATING BOARDFOOT OF LUMBER

Although the International System (SI) or Metric System had already superseded the English System of measure, the board foot as a unit of measure for determining the volume of lumber is still being used by the furniture & cabinet maker and construction industry. This is because lumbers are sold in terms of board foot.

A board foot is actually one square foot of lumber of one inch thick

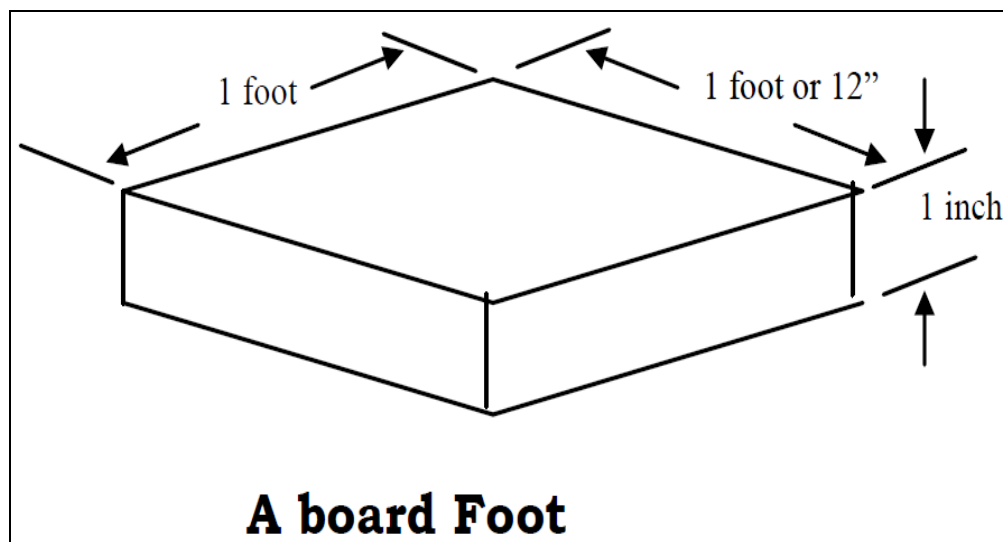

The formula used in computing board foot is:

$$\text{Board foot (Bd. Ft.)} = \frac{T \times W \times L}{12}$$

Where:

T = Thickness in inches

W = Width in inches

L = Length in feet

Note: This formula is being used for sawed wood of commercial dimension.

Example: Compute the board foot of lumber whose dimension is 2" x 4 "x 12"

Steps 1. *Identify the given data*

$$\text{Given. } T = 2''$$

$$W = 4''$$

$$L = 12''$$

Step 2. *Determine what is being asked*

Find the Bd. Ft. = ?

Step 3. *State the formula*

$$\text{Formula: Bd. Ft.} = \frac{T \times W \times L}{12}$$

Step 4. *Substitute the given data in the formula, then solve.*

Solution:

$$\text{Bd. Ft.} = \frac{T \times W \times L}{12}$$

$$12$$

$$= \frac{2'' \times 4'' \times 12''}{12}$$

$$= 96/12$$

$$= 8 \text{ Bd. Ft.}$$



How Much Have You Learned?

Self-Check 2.1

I. Enumerate the following.

1-2 – What are the two 2 systems of measurements

3-5 - Give at least 3 units of linear measurements in the English system

6-9 – Give at least 3 units of linear measurements in the Metric System

II. Read the following measurements.

1 – 5.

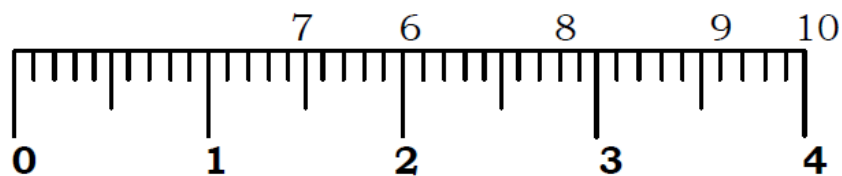
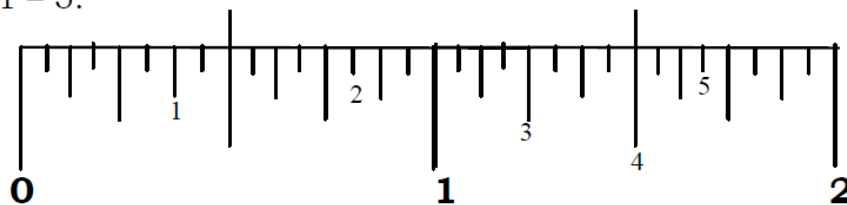

1. _____
2. _____
3. _____
4. _____
5. _____
6. _____ cm
7. _____ mm
8. _____ mm
9. _____ mm
10. _____ cm

III. Convert the following fractions to decimals.

1. $\frac{1}{4}$
2. $\frac{3}{4}$
3. $\frac{5}{8}$
4. $\frac{7}{8}$
5. $\frac{9}{16}$
6. $\frac{11}{5}$
7. $\frac{13}{4}$
8. $\frac{9}{5}$
9. $6\frac{3}{5}$
10. $3\frac{2}{3}$

IV. Convert the following measurement to their unit equivalents

1. 4 meters = _____ cm.
2. 4 meters = _____ ft.
3. 8 feet = _____ inches
4. 20 inches = _____ cm
5. 236.22 inches = _____ meters

V. Identify the different ways of taking dimensions.

1.



2.



3.



4.



5.



Refer to the Answer Key. What is your score?



How Do You Apply What You Have

Show that you learned something by doing this activity.

Operation Sheet 2.1

Directions: Compute the number of board feet of lumber with the following dimensions.

1. 2" x 6" x 12"
2. 3" x 4" x 10"
3. 2" x 2" x 16"
4. 2" x 12" x 8"
5. 4" x 4" x 18"



How Well Did You Perform?

Find out by accomplishing the Scoring Rubric honestly and sincerely. Remember it is your learning at stake!

Proceed to the next lesson if your score in the test is 35 and above.



How Do You Extend Your Learning?

Assignment Sheet 1.1

- Practice accurate measuring practices in every carpentry works.
- Apply consciousness and proper computations in every carpentry requirement.



Congratulations! You did a great job! Rest and relax a while then move on to the next lesson. Good luck!

REFERENCES

LO1

- Barba, Joshua A., Carpentry, ConvergeLink Books Corp., Philippines, 2006.
- Better Homes and Gardens FCM, Meredith Books Des Moines, Iowa, 2003

LO 2

- John L. Feirer, Cabinet Making and Millwork, Second Edition
- B. Fred W. Zimmerman and Larry J. Mc Ward, Exploring Woodworking, Fundamentals of Technology
- Tomas M. Quilang, Handicrafts Handbook, 1975
- Reader's Digest Book of Skills and Tools
- Gilbert Hutching, Eugene Martin and Mario Coleman, Working with Wood, 1982,
- John L. Feirer, Wood Technology and Processes,
- Gregorio T. Amano, Fundamental Woodworking, 1976,

LESSON 4

Interpret Drawings and Plans



LEARNING OUTCOMES:

At the end of this Lesson, you are expected to do the following:

- LO 1. analyze signs, symbols and data;
- LO 2. interpret technical drawings and plans; and
- LO 3. apply freehand sketching.



Definition of Terms

Axis – line about which a body turns or rotates

Design – drawing showing the plan, elevations, sections, and other features.

Detail drawing – separate drawing showing a small part of a machine or structure

Dimension – definite measure shown on a drawing in detail

Isometric Drawing – drawing which resembles a perspective drawing

Orthographic Projection – arrangement in a drawing of the three principal views of an object

Perspective Drawing – the representation of an object on a plan surface, pertaining to materials, styles and finish presented as to have the same appearances as when seen from a particular viewpoint

Projections – the cutting out of any part or any member of a structure

Reduced – made smaller than the actual size as in the size of object

Scaled Drawing – drawing plan made according to a scale, smaller than the actual work

Sketch – freehand drawing of an object

Specification – written instruction to the worker containing all the information

LEARNING OUTCOME 1

Analyze signs, symbols and data

PERFORMANCE STANDARDS

- Sign, symbols, and data are identified according to job specifications.
- Sign, symbols, and data are determined according to classification or as appropriate in drawing.



Materials

1. Drawing Paper
2. Pencil
3. Plans
4. Drawing Instruments



What Do You Already Know?

Pretest LO 1

Let us determine how much you already know about analyzing signs, symbols and data. Take this test.

Directions: Match Column A with Column B.

Column A

1. Very light line used to “*block in*” an object. These lines are made so light that little or no erasing is needed. They serve as base for darkening in the permanent line
2. Heavy, solid line used to frame in the drawing
3. A medium line used to show edges and contours visible to the eye
4. A medium line used to show edges and contours not visible to the eye
5. A light line used as axis of symmetry
6. Light thin lines used to show the sizes of the object. Extension lights start about 1/16” from visible or object line. The dimension line is broken near the center for the dimension.
7. Wavy line draws freehand for the same purpose as long break.

Column B

- a. Long break line
- b. Dimension line
- c. Centerline
- d. Invisible line
- e. Visible line
- f. Borderline
- g. Construction line

Now check your answer using the Answer Key. If you got 90 - 100 % of the items correctly, proceed to the next Learning Outcome. If not, do the next activity/ties again to gain knowledge and skills required for mastery.



What Do You Need To Know?

Read Information Sheet 1.1 very well then find out how much you can remember and how much you learned by doing the Self-check 1.1.

Information Sheet 1.1

DRAWING SIGNS AND SYMBOLS

Alphabet of Lines

In sketching orthographic drawing, certain conventional lines are used for a definite purpose. These lines are commonly called **Alphabet of Lines**.

Lines	Width and Character of Lines	Applications
Visible line	<p>THICK Width 0.75 – 0.96 mm (.030 – .038")</p>	
Hidden line	<p>0.8 mm (.03") THIN 3.2 mm (.12") Width 0.38 – 0.55 mm (.015 – .022")</p>	
Section line	<p>THIN Width 0.38 – 0.55 mm (.015 – .022")</p>	
Center line	<p>19 – 38 mm (.75 – 1.50") 3.2 mm (.12") 1.6 mm (.06") THIN Width 0.38 – 0.55 mm (.015 – .022")</p>	
Dimension line, Extension line, Leaders	<p>90.5 THIN Width 0.38 – 0.55 mm (.015 – .022")</p>	

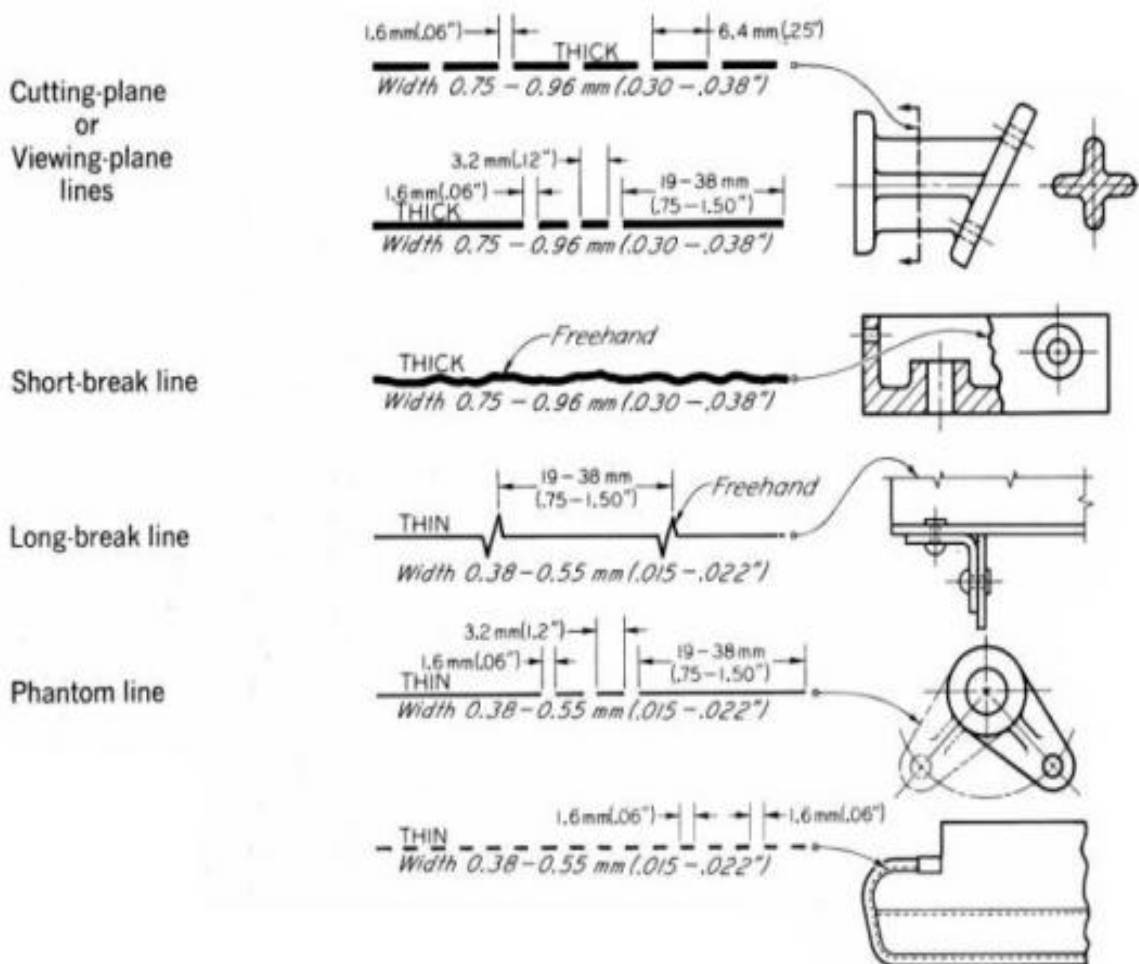

USES OF ALPHABET OF LINES

Construction line	Very light line used to “block in” an object. These lines are made so light that little or no erasing is needed. They serve as base for darkening in the permanent line
Borderline	Heavy, solid line used to frame in the drawing
Visible line	A medium line used to show edges and contours not visible to the eye.
Invisible line	A medium line used to show edges and contours not visible to the eye.
Centerline	A light line used as axis of symmetry. Used for center of circle and arcs. Sometimes the symbol is shown
Dimension line	Light thin lines used to show the sizes of the object. Extension lights start about 1/16” from visible or object line. The dimension line is broken near the center for the dimension.
Long break line	Heavy line draws freehand for same purpose as long break.



How Much Have You Learned?

Self-Check 1.1

Directions: Enumerate the different kinds of lines.

1. _____
2. _____
3. _____
4. _____
5. _____
6. _____
7. _____
8. _____
9. _____
10. _____

Refer to the Answer Key. What is your score?



How Do You Apply What You Have

Show that you learned something by doing this activity.

Operation Sheet 1.1

Directions: Identify the kinds of line used in any drawing in carpentry.

LEARNING OUTCOME 2

Interpret technical drawings and plans

PERFORMANCE STANDARDS

- Necessary tools, materials and equipment are identified according to the plan.
- Components, assemblies or object are recognized as per job requirement.
- Dimensions and specification are identified according to job requirements.



Materials

- Drawing Paper
- Pencil
- Plans
- Drawing Instruments



What Do You Already Know?

Pretest LO 2

Directions: Identify the different tools and materials in carpentry.

1. _____
2. _____
3. _____
4. _____
5. _____
6. _____
7. _____
8. _____
9. _____
10. _____

Now check your answer using the Answer Key. If you got 90 - 100 % of the items correctly, proceed to the next Learning Outcome. If not, do the next activity/ties again to gain knowledge and skills required for mastery.



What Do You Need To Know?

Read Information Sheet 2.1 very well then find out how much you can remember and how much you learned by doing Self-check 2.1.

Information Sheet 2.1

CENTER TABLE COMPONENTS

- Legs – 4 pcs. 45 mm x 45mm x500 mm wood (tanguile)
- Rails – (short) 2 pieces 25 mmx70 mm x 600 mm
- Rails – (long) 2 pieces 25 mm x 70mm x 800 mm
- Top – 1pcs 25mmx600 x 800mm plywood/ plyboard

Assemblies Joints

- Mortise and tendon joint – for the rails and legs (see details on the attached working drawing)

Dimensions and specification (See dimensions and specifications on the attached working drawing)

- Legs must be tapered.
- All joints must be filled with glue.
- All wood used must be tanguile.
- All dimensions must be in millimeters.

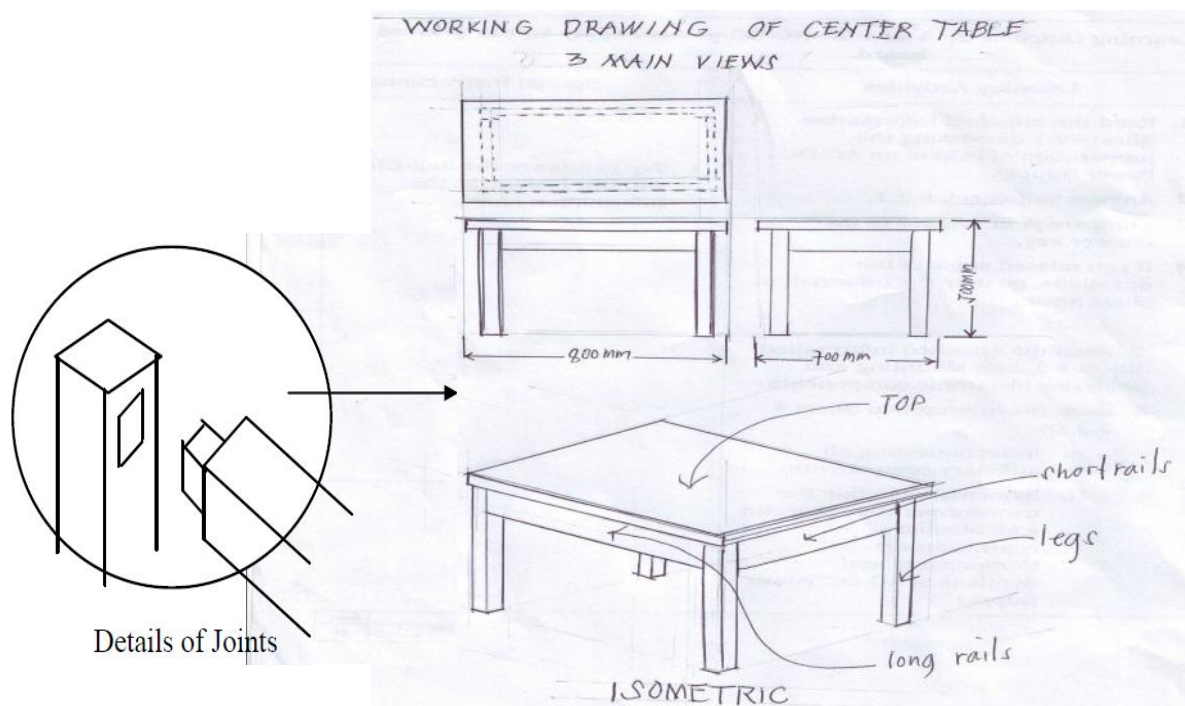

IDENTIFYING TOOLS, MATERIALS AND EQUIPMENT



How Much Have You Learned?

Self-Check 2.1

Directions: Answer the following questions about constructing a center table.

- A. What are the different components of the center table based on the working drawing?
- 1.
 - 2.
 - 3.
 - 4.
- B. What are the specified joints used in joining the legs and rails of the center table?
- 1.
 - 2.
- C. List down different specifications on the construction of the center table.
- 1.
 - 2.
 - 3.
 - 4.

Refer to the Answer Key. What is your score?

LEARNING OUTCOME 3

Apply freehand sketching

PERFORMANCE STANDARDS

- Correct freehand sketching is produced in accordance with the job requirements.



What Do You Already Know?

Let us determine how much you already know about applying freehand sketching. Take this test.

Pretest LO 3

Directions: Do the Orthographic Drawing of the Given Isometric Figure.

Given:

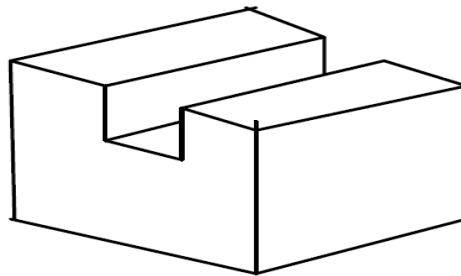

ISOMETRIC

Now check your answer using the Answer Key. If you got 90 - 100 % of the items correctly, proceed to the next Learning Outcome. If not, do the next activity/ties again to gain knowledge and skills required for mastery.



What Do You Need To Know?

Read Information Sheet 3.1 very well then find out how much you can remember and how much you learned by doing Self-check 3.1.

Information Sheet 3.1

STEPS IN SKETCHING AN ISOMETRIC BOX

1. Draw a vertical axis.

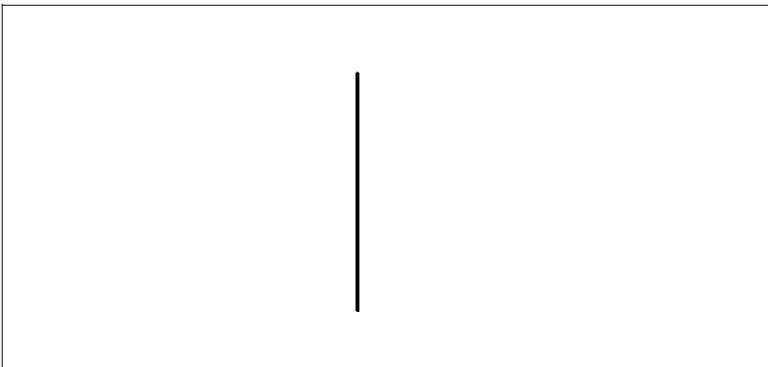

2. Draw left and right axis.

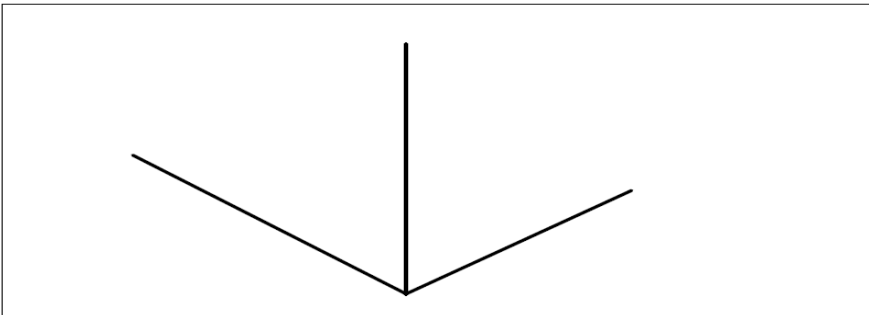

3. Determine the width and length of the box and then draw a vertical line

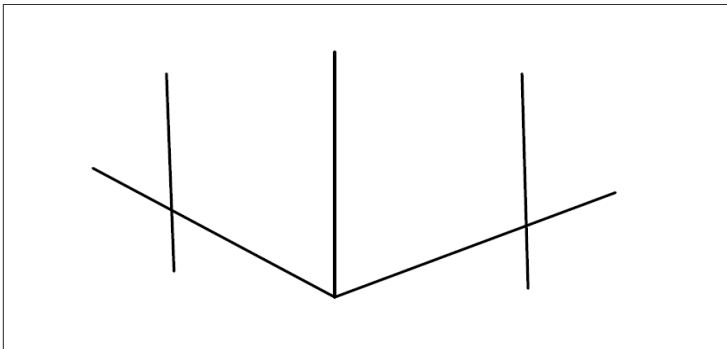

4. Draw a left and right axis to the determined height of the box.

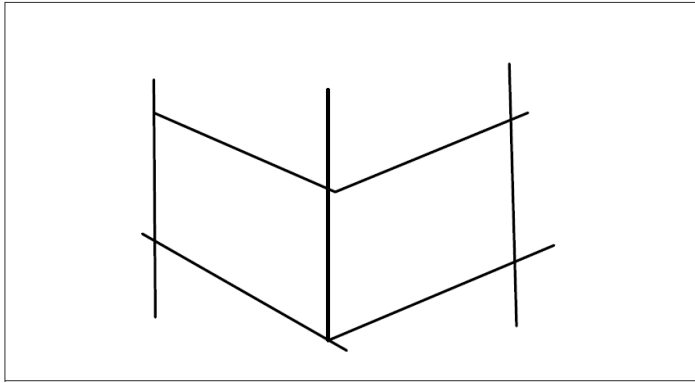

5. Project a line parallel to the left and right axis

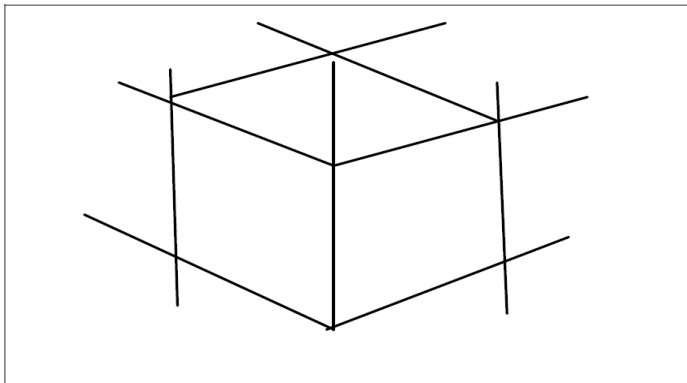

6. Label the box to determine the top, front and the right side view

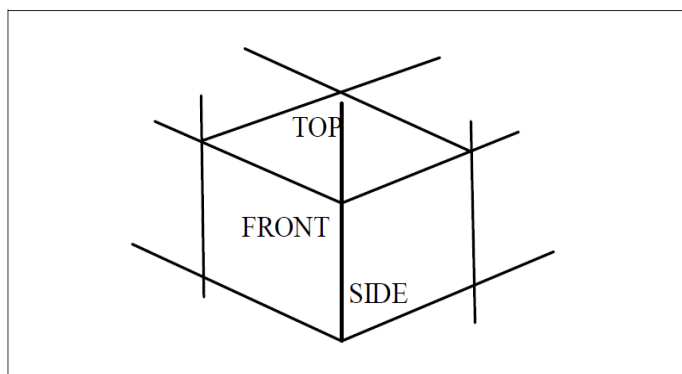

STEPS IN SKETCHING ORTHOGRAPHIC DRAWING

1. Study the object to be drawn (See isometric drawing on operation sheet (3-1))
2. Draw the top view, front view and the right side view

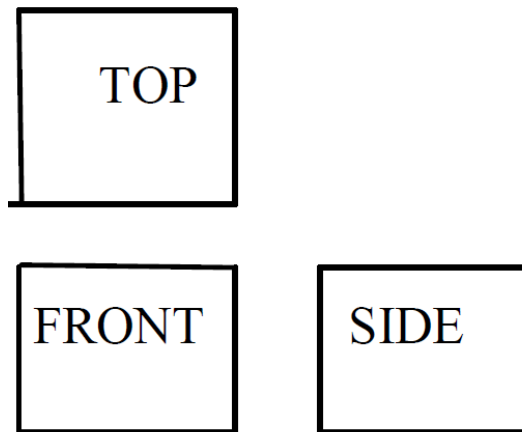

3. Draw a simple drawing using block as model. Try to study the given view.

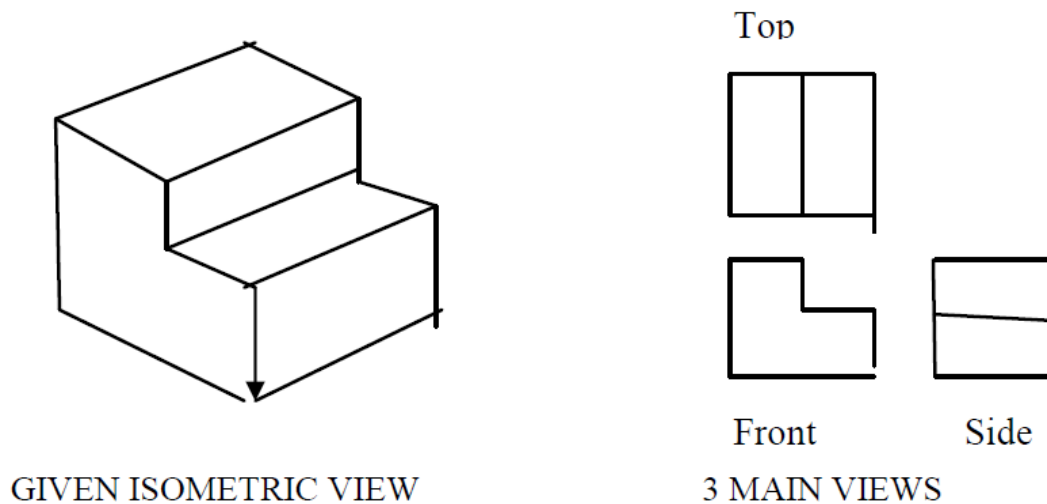

SKETCHING ORTHOGRAPHIC DRAWING

STEPS IN SKETCHING ISOMETRIC DRAWING OF A GIVEN ORTHOGRAPHIC FIGURE

1. Study the object to be drawn (see orthographic drawing).
2. Draw the isometric drawing.
3. Lay out the front view.
4. Sketch the top view and side view.
5. Finalize the object to complete the drawing.

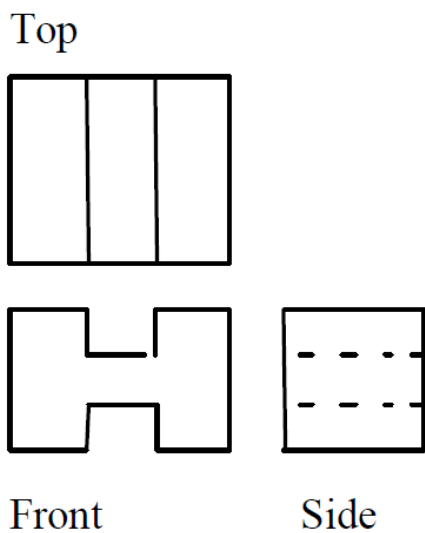

ORTHOGRAPHIC

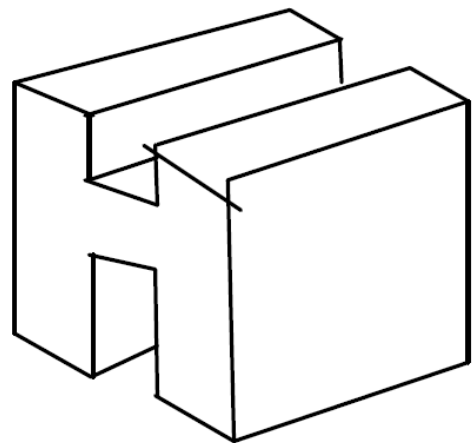

ISOMETRIC



How Much Have You Learned?

Self-Check 1.1

- I. Sketch an isometric box.
- II. Do the Orthographic Drawing of the given Isometric Figure.

Given:

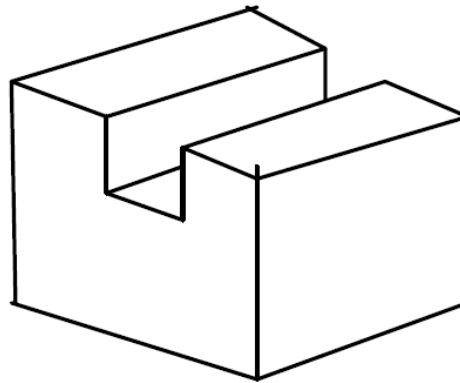

ISOMETRIC

- III. Draw the Isometric of the given 3 main views.

Given:

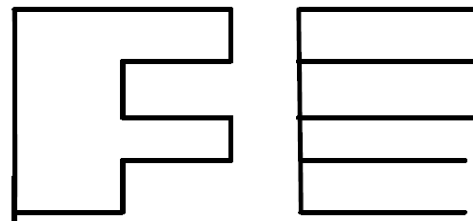
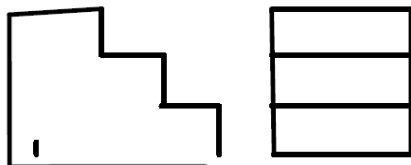
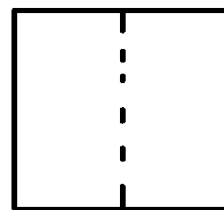
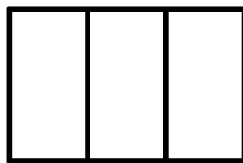

3 MAIN VIEWS

3 MAIN VIEWS



How Do You Apply What You Have

Show that you learned something by doing this activity.

Operation Sheet 1.1

Directions: Draw the center table using the following measurements:

- 1 m. long
- 500mm wide
- 600mm high



Congratulations! You did a great job! Rest and relax a while then move on to the next lesson. Good luck!

REFERENCES

LO1

- Barba, Joshua A., Plumbing, CoverLink Books Corp., Philippines, 2006.
- Better Homes and Gardens Plumbing, Meredith Books Des Moines, Iowa, 2003.

LO 2

- German Manaois, Drafting 1 and 2 Phoenix Publishing 1983.
- Norman Stirling Introduction to technical Drawing 1977.

LO 3

- Giesecke, Mitchelle and Spencer: Technical Drawing, The Macmilan Edition, 1949.
- French and Vierck Engineering Drawing: Mac Graw, Hillbook Company, 10th edition 1960.

LESSON 5

Practice Occupational Health and Safety Procedures



LEARNING OUTCOMES:

At the end of this Lesson, you are expected to do the following:

- LO 1. identify hazards and risks;
- LO2. evaluate hazards and risks;
- LO3. control hazards and risks; and
- LO4. maintain occupational health and safety awareness.



Definition of Terms

Accident – is an event occurring unintentionally or by chance

Control – means to direct or determine

First Aid – as it implies includes all forms of remedies given immediately to humans in order to minimize or prevent casualties or fatalities caused by accidents or normal course of time

Hazard – involves unforeseen incident that is physically unfavorable to humans or animals

Occupation – is an activity in which one is engaged in

Safety – state of being out of danger, uninjured, not involving risk

Sanitize – to maintain high standard of housekeeping

Self-Discipline – refers to doing things spontaneously without being told or ordered

Signs – generally refer to objects made by flat sheet metal or wood suspended by a stand or nailed on the post or wall which are located strategically

Sort – to take out unnecessary items and dispose the same

Sweep – means to clean the workshop

Symbols – are generally common illustrations printed on the signs which sometimes carry a descriptive word or few words

Systematize – means to arrange necessary items in good order for use

Toxic – deadly, harmful and poisonous

Acronyms

OHSP – Occupational Health and Safety Procedures

PPE – Personal Protective Equipment

LEARNING OUTCOME 1

Identify hazards and risks

PERFORMANCE STANDARDS

- Safety regulations and workplace safety and hazard control practices and procedures are clarified and explained based on organization procedures
- Hazards/risks in the workplace and their corresponding indicators are identified to minimize or eliminate risk to co-workers, workplace and environment in accordance with organization procedures
- Contingency measures during workplace accidents, fire and other emergencies are recognized and established in accordance with organization procedures



Materials / Resources

1. Mask
2. Gloves
3. Goggles
4. Hair Net/cap/bonnet
5. Face mask/shield
6. Ear muffs
7. Apron/Gown/coverall/jumpsuit
8. Anti-static suits



What Do You Already Know?

Let us determine how much you already know about identifying hazards and risks. Take this test.

Pretest LO 1

Directions: Choose the letter of the correct answer. Write your answer on a separate sheet.

1. It is the condition where high standard of good housekeeping is maintained so that there is no dust and rust anywhere.
A. sort
B. systematize
C. sweep
D. sanitize
2. Which is practiced when your colleagues decide with you which things to put where taking into account the flow of your work?
A. sort
B. systematize
C. sweep
D. sanitize
3. It ensures the safety of the construction workers.
A. signs, signal & barricades
B. danger signs
C. exit signs
D. safety instructions signs
4. Which shall be used when an immediate hazard exists?
A. signs, signal & barricades
B. danger signs
C. exit signs
D. safety instructions signs
5. Which shall be used as temporary means of warning an existing hazard such as defected tools, equipment, etc?
A. danger Signs
B. accidental Prevention Tags
C. traffic signs
D. directional signs

Now check your answer using the Answer Key. If you got 90 - 100 % of the items correctly, proceed to the next Learning Outcome. If not, do the next activity/ties again to gain knowledge and skills required for mastery.



What Do You Need To Know?

Read Information Sheet 1.1 very well then find out how much you can remember and how much you learned by doing the Self-check 1.1.

Information Sheet 1.1

HAZARDS AND RISKS IDENTIFICATION AND CONTROL

Requirements in Conducting/Identifying Hazards

- Survey the workplace to identify hazards
- This survey must be in writing and must be available to all workers
- Determine whether any hazard requires Personal Protective Equipment
- Pay special attention to working conditions or process that can produce hazards.
- Reassess hazards whenever necessary, especially when new equipment is installed to avoid accidents.
- Any reassessment must be written and must be available to workers upon request.

WORKING CONDITIONS THAT CAN PRODUCE HAZARDS

1. Falling objects
2. Objects that can puncture skin
3. Objects that could roll over worker's feet
4. Toxic chemicals
5. Heat
6. Harmful Dust
7. Radiation

Signs, Signals and Barricades

- Signs, signals and barricades are important, if not critical, to the safety of the construction workers.

Accident Prevention Signs and Tags

1. **General.** Signs and symbols required shall be visible at all times when work is being performed, and shall be removed or covered promptly when the hazard does not exist anymore.
2. **Danger Signs.** Danger signs shall be used only where an immediate hazard exists.



Danger signs should be read as the predominating color for the upper panel; outline on the borders; and a white lower panel for additional sign wording.



3. **Caution Signs.** Caution signs shall be used only to warn against or caution against practices.

Caution sign shall have yellow as the predominating color; black upper panel and borders; yellow lettering of "caution" on the black panel; and the lower yellow panel for the additional sign wording. Black lettering shall be used for additional wording.

Standard color of the background shall be yellow; and the panel, black with yellow letters. Any letter used against the yellow background shall be black. The colors shall be those of opaque glossy samples.

4. **Exit Signs.** Exit signs, when required, shall be lettered in legible red letters, not less than 6 inches high, on a white field and the principal stroke of the letters shall be at least three-fourths in width.



5. **Safety Instructions Signs.** Safety instruction signs, when used, shall be with green upper panel with white letters to convey the principal message. Any additional wording on the sign shall be black letters on the white background.



6. **Directional Signs.** Directional signs, other than automotive traffic signs specified in the paragraph below, shall be white with a black panel and white directional symbol. Any wording on the sign shall be black letters on the white background.



7. **Traffic Signs.** Construction areas shall be posted with legible traffic signs at point hazard. All traffic control signs or devices used for protection of construction workers shall conform to Occupational Safety and Health Administration (OSHA) standards.



8. **Accidental Prevention Tags.** Accident prevention tags shall be used as temporary means of warning of an existing hazard such as defected tools, equipments, etc. They shall not be used in place of, or as a substitute for, accident prevention signs. Specifications for accident prevention tags similar as shown below shall apply.





How Much Have You Learned?

Self-Check 1.1

A. Write the letter of your choice on your answer sheet.

1. Your employer must conduct a hazard assessment in order to _____.
 - A. avoid accident
 - B. promote accident
 - C. eliminate workers
 - D. None of the above
2. OSH means _____.
 - A. Occupational Service Healthy
 - B. Occupational Safe and Healthy
 - C. Occupational Safety and Health
 - D. None of the above
3. Identifying hazards makes you _____.
 - A. safe from working
 - B. comfortable while working
 - C. work efficient
 - D. all of the above
4. Who should first know about the accident that happened in your shop?
 - A. principal
 - B. nurse
 - C. teacher
 - D. doctor
5. Accidents can be prevented _____.
 - A. through proper care and maintenance of tools and equipment
 - B. right attitude toward work
 - C. if you have a good knowledge about safety practices
 - D. None of the above

B. Draw the following signs correctly.

1. Stop
2. Danger
3. Poisonous
4. Slippery when wet
5. Up

Refer to the Answer Key. What is your score?

LEARNING OUTCOME 2

Control hazards and risks

PERFORMANCE STANDARDS

- OHS procedures for controlling hazards and risk are strictly followed.
- Procedures in dealing with workplace accidents, fire and emergencies are followed in accordance with the organization's OHS policies.
- Personal protective equipment (PPE) is correctly used in accordance with organization's OHS procedures and practices.
- Procedures in providing appropriate assistance in the event of workplace emergencies are identified in line with the established organizational protocol.



Materials

- OHS Manuals
- Personal Protective Equipment
- Chart/pictures



What Do You Already Know?

Let us determine how much you already know about evaluating hazards and risks. Take this test.

Pretest LO 2

Directions: Identify the following Personal Protective Equipment (PPE)

1.



2.



3.



5.



6.



Now check your answer using the Answer Key. If you got 90 - 100 % of the items correctly, proceed to the next Learning Outcome. If not, do the next activity/ties again to gain knowledge and skills required for mastery.



What Do You Need To Know?

One way of controlling hazards and risks in the workplace is to use the proper protective equipment applicable to the work condition.

Information Sheet 2.1

Read the Information Sheet very well then find out how much you can remember and how much you learned by doing the Self-check.

Signs and their location:

1. **Danger Signs** – are used only where immediate hazards exist. They are printed in red as the predominating color.
2. **Caution Signs** – are used to warn against potential hazards.
3. **Exit Signs** – are printed in legible red letters for exits.
4. **Safety Instructions Signs**
5. **Accidental Prevention Tags** – are used as temporary means of warning to existing hazards, such as deflection, tools and equipment.
6. **Barricades** – are used for protection of employees.

Personal Protective Equipment (PPE)

Here are the types of Personal Protective Equipment (PPE) use for safety purposes:

A. Face protection

Goggles and face protection must be used when at risk from flying particles, liquid chemicals, acids or caustic liquids and chemical gases. There are various goggles for face protection with certain design criteria for safety.



B. Foot Protection

Safety shoes with impact protection are used in work areas where heavy objects or tools could be accidentally dropped on the feet. Safety shoes with puncture protection are required when working around nails, wire tacks, scrap metals and other objects that could pierce the feet.



C. Hand Protection

Gloves are required to protect your hands from cuts, scrapes, punctures, burns, chemical absorption, and exhaust temperatures. It is crucial that the type of glove being used is the right one for the job.



D. Hearing Protection

Appropriate **ear muffs or ear plugs** must be made available as a last resort if it is not possible to make the workplace less noisy. The requirement is a small part of the occupational noise exposure standard which requires employers to ensure that workers are exposed to less than 90 decibels of noise over an 8 hour period.



E. Respirators

Appropriate **respirators** must be worn as a last resort if it is not possible





How Much Have You Learned?

Self-Check 2.1

A. Define and describe the following:

- a. Danger Signs - _____
- b. Caution Signs - _____
- c. Exit Signs - _____
- d. Accidental Prevention Tags - _____
- e. Barricades - _____

B. Give an example for each and give its use and importance.

- 1. Respirators
- 2. Foot Protection
- 3. Hand Protection
- 4. Hearing Protection
- 5. Face Protection

Refer to the Answer Key. What is your score?



What Do You Already Know?

Let us determine how much you already know about control hazards and risks. Take this test.

Pretest LO 2

Directions: Write the letter of the correct answer on your Answer Sheet.

1. Conducting hazard assessment to a workplace should be done_____.
 - A. during working hours
 - B. after working hours
 - C. before working hours
 - D. all of the above
2. Observing good housekeeping _____.
 - A. prevents fire
 - B. makes for easy location of tool and materials needed
 - C. both a and b
 - D. none of the above
3. In dealing with accidents, the first thing to do is to_____.
 - A. stay calm and study the situation
 - B. apply first aid
 - C. call the attention of your teacher
 - D. all of the above
4. Accidents can be prevented _____.
 - A. thru proper cares and maintenance of tools and equipment
 - B. right attitude towards works
 - C. if you have enough knowledge about safety practices
 - D. all of the above
5. When an injury occurs, how soon should it be treated?
 - A. After class hours
 - B. Immediately
 - C. Both a and b
 - D. Later

Now check your answer using the Answer Key. If you got 90 - 100 % of the items correctly, proceed to the next Learning Outcome. If not, do the next activity / ties again to gain knowledge and skills required for mastery.



What Do You Need To Know?

Read Information Sheet 2.2 very well then find out how much you can remember and how much you learned by doing Self-check 2.2.

Information Sheet 2.2

Topic 1: Occupation Health and Safety (OHS) Procedures for controlling hazards and risks.

1. *Conduct a hazard assessment like*
 - Survey workplace to identify hazards (put them in writing)
 - Determine whether any hazard required Personal Protective Equipment.
 - Pay attention to working conditions that can produce hazards
 - Reassess hazards whenever necessary, especially when new equipment is installed
2. *Select appropriate equipment.* Ensure that all Personal Protective Equipment used is the right kind of equipment for the job, and is maintained properly
3. Have knowledge on the following:
 - Which PPE is necessary
 - How to identify if it fits properly
 - How to put on, remove, adjust and wear Personal Protective Equipment (PPE)
 - How to dispose of Personal Protective Equipment(PPE)
 - The limitation of using Personal Protective Equipment (PPE)

Topic 2: Procedure in dealing with workplace, accidents, fire and Emergencies.

- A. *Dealing with Accidents*
 1. Keep calm, don't panic and study the situation.
 2. Report immediately to your teacher
 3. Apply first aid to the victim while waiting for a nurse or a physician
 4. Bring the patient to the nearest clinic or hospital
- B. *Dealing with Fire*
 1. Do not panic, stay calm.
 2. Call the attention of everybody.
 3. Use your firefighting equipment to control extinguish the fire.
 4. Call the office or the fire station
- C. *Dealing with Emergencies*
 1. Stay calm and study the situation.
 2. Call the attention of your teacher.



How Much Have You Learned?

Self-Check 2.2

Directions: Write the letter of the correct answer on your Answer Sheet.

1. Conducting hazard assessment to a workplace should be done _____.
 - A. during working hours
 - B. after working hours
 - C. before working hours
 - D. all of the above
2. Observing good housekeeping _____.
 - A. prevents fire
 - B. makes for easy location of tool and materials needed
 - C. both a and b
 - D. none of the above
3. In dealing with accidents , the first thing to do is to _____.
 - A. stay calm and study the situation
 - B. apply first aid
 - C. call the attention of your teacher
 - D. all of the above
4. Accidents can be prevented _____.
 - A. thru proper cares and maintenance of tools and equipment
 - B. right attitude towards works
 - C. if you have enough knowledge about safety practices
 - D. all of the above
5. When an injury occurs, how soon should it be treated?
 - A. after class hours
 - B. immediately
 - C. both a and b
 - D. later

Refer to the Answer Key. What is your score?



How Do You Apply What You Have Learned?

Show that you learned something by doing this activity.

Activity Sheet 2.1

I. For the created team

Select a team that will perform this activity with you.

- Re-arrange the shop layout according to the pointers on work simplification designed to minimize occupational hazards, thus promotes workers health and safety.
- Prepare a plan which shall be executed for a maximum of ten minutes.
- The team performance shall be evaluated by the audience using deliberative judging.

II. For the audience-judges

Students who were not selected as team members shall play the role of audience-judges.

- While the team deliberates on the shop layout to be executed, the audience-judges conduct a buzz session headed by a leader who shall act as the supreme judge in order to craft a rubric for the team performance.
- After the team has performed, the audience-judges shall present individually their comments/remarks backed up with appropriate justifications.
- On the other hand, the team members shall not make any comment or remark; instead, they shall listen or give an answer whenever asked.
- The final rating of the team shall be announced by the supreme judge who shall act as mediator or set a ruling, whenever possible.

III. **Each group** shall initiate a 10 minute-panel discussion on Occupational Health and Safety. The following are the general guidelines for the groups in holding the panel discussion:

- The group may invite experienced persons who shall sit as panel guests. The group members shall serve as panelists, therefore, they are responsible for shooting particular questions or topics for discussion.
- Identified group members may play the role of experienced guests who are responsible for shading lights on the issues or concerns on hand; Others shall play as panelists and responsible for running a quality show.



How Well Did You Perform?

**Find out by accomplishing the Scoring Rubric honestly and sincerely.
Remember it is your learning at stake!**

Panel Discussion Rubric

(Adapted from: <http://www-tc.pbs.org/pov/pov2001/promises/lessonplan.pdf>)

Student _____

___√+ **Consistently** ___√ **Usually** ___√- **Seldom**

Knowledge:

- ___ The student (group) used research to advance arguments and defend positions.
- ___ Research was effectively applied to arguments.

Understanding:

- ___ The student (group) demonstrates understanding of the issue.
- ___ The student (group) presented key points.
- ___ The student (group) presented original ideas.
- ___ The student (group) was able to use examples or analogies to defend an argument.
- ___ The student (group) demonstrated empathy for the cause he or she represented.
- ___ The student (group) showed respect for others' opinions.

Communication:

- ___ The student (group) was logical in presenting arguments.
- ___ The student (group) was able to communicate effectively and clearly.
- ___ The student (group) incorporated key terminology/vocabulary.

Participation:

- ___ The student contributed to the discussion.
- ___ The student tended to dominate a discussion, thereby hindering others' participation.

For group evaluation:

- ___ All students participated in the discussion.
- ___ Students within the group tended to dominate discussion within the group, hindering other group members' participation?

LEARNING OUTCOME 3

Maintain occupational health and safety awareness

PERFORMANCE STANDARDS

- Procedures in emergency related drill are strictly followed in line with the established organization guidelines and procedures
- OHS personal records are filled up in accordance with workplace equipment
- PPEs are maintained in line with organization guidelines and procedures



Materials

- Personal protective equipment
- OHS personal records



What Do You Already Know?

Let us determine how much you already know about maintain occupational health and safety awareness. Take this test.

Pretest LO 3

Directions: Encircle the letter of the correct.

1. Who introduced the 5Ss principle?
A. English
B. Filipinos
C. Japanese
D. Japan
2. Which of the following are the 5Ss?
A. Seiri, Seiton, Sweep, Seiketsu Shitzu
B. Seiri, Seiton, Seiso, Sanitize, Shitzu
C. Sort, Seiton, Sweep, Seiketsu, Shitzu
D. Seiri, Systematize, Seiso, Seiketsu, Shitsu

3. It refers to the cleaning of workshop.

A. Seiton	C. Seiso
B. Seiri	D. Seiketsu

4. It is the condition where high standard of good housekeeping is maintained so that there is no dust and rust anywhere. .

A. Sort	C. Sweep
B. Systematize	D. Sanitize

5. Which is practiced when your colleagues decide with you which things to put where taking into account the flow of your work?

A. Sort	C. Sweep
B. Systematize	D. Sanitize

6. Its advantage is to promote camaraderie among workers in the company.

A. Shitsuke	C. The 5Ss
B. Seiton	D. All of the above

7. It ensures the safety of the construction workers.

A. Signs, Signal & Barricades	C. Exit Signs
B. Danger Signs	D. Safety Instructions Signs

8. Which shall be used when an immediate hazard exists?

A. Signs, Signal & Barricades	C. Exit Signs
B. Danger Signs	D. Safety Instructions Signs

9. Which shall be used as temporary means of warning an existing hazard such as defected tools, equipment, etc?

A. Danger Signs	C. Traffic Signs
B. Accidental Prevention Tags	D. Directional Signs

10. Which is a major factor for the prevention of shop accidents?

A. Signs, symbols, barricades	C. Attitude
B. The 5Ss Principle	D. All of the above

Now check your answer using the Answer Key. If you got 90 - 100 % of the items correctly, proceed to the next Learning Outcome. If not, do the next activity/ties again to gain knowledge and skills required for mastery.



What Do You Need To Know?

Read the Information Sheet 3.1 very well then find out how much you can remember and how much you learned by doing the Self-check 3.1.

Information Sheet 3.1

Which is an Ideal Working Station?



Fig.1. Working Station 1



Fig. 2 Working Station 2

What is 5S?

The 5Ss are Japanese words that start with letter S. But in the Philippines, some thought of 5 English words that all begin with letter S which is equivalent to these Japanese words; it is therefore necessary to remember the Japanese' 5Ss. What is important aside from retaining this into our minds is to make it part of our daily habit.

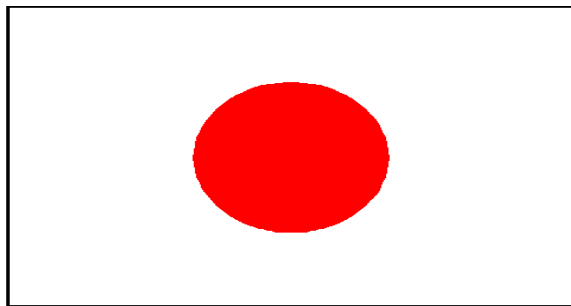

Below are the **5Ss** and their English equivalent:

<u>Japanese</u>	<u>English</u>	<u>Brief Explanation</u>
SEIRI	SORT	Take out unnecessary items and dispose
SEITON	SYSTEMATIZE	Arrange necessary items in good order for use
SEISO	SWEEP	Clean your workshop
SEIKETSU	SANITIZE	Maintain high standard of housekeeping
SHITSU	SELF-DISCIPLINE	Do things spontaneously without being told or ordered

5Ss is not simply a list of action items. It is an integrated concept of action, condition and culture. The nature and implication of each S needs to be understood as follows:

1. **SEIRI (SORT)** is an Action to identify and eliminate all unnecessary items from your workplace.
2. **SEITON(SYSTEMATIZE)** is an ACTION to put every necessary items in good order.
3. **SEISO (SWEEP)** is an ACTION to clean your workplace thoroughly.
4. **SEIKETSU (SANITIZE)** is a CONDITION where high standard of good housekeeping is maintained so that there is no dust and rust anywhere.
5. **SHITSUKE (SELF-DISCIPLINE)** is a CONDITION where all members practice accordingly. It is a CULTURE.

How to practice 5Ss?

1. **SEIRI (SORT)** means “take out unnecessary items and dispose’

Step 1 – Look around your workplace. Discover and identify items which are unnecessary to your work. Then, dispose all unnecessary items.
“NEVER KEEP ANYTHING WHICH IS UNNECESSARY TO YOUR WORK.”

Step 2 – If you cannot decide whether an item is necessary or not, put “DISPOSAL NOTICE” with the data on the item and set item aside.

Step 3 – After a period, say two months, check if someone has the item or not. If no one needed the item, that means the item is not needed for your work.

Note: Disposal can be done in either of the following ways:

1. Sell it to outside of the workplace.
2. Move to other department/section where the item is needed.
3. Throw it away, dispose as garbage.
4. In disposing the belongings, it is better to make people know who has the authority for disposal.
5. It is also better to make people know where to return excessive stock of materials and supplies.
6. While looking around for unnecessary items in your workplace, look at every nook like when you are looking for cockroaches. It will be a bonus to you if you find some useful items.

2. **SEITON** (SYSTEMATIZE) means “Arrange necessary items in good order to use”

Step 1. Make sure that all unnecessary items are eliminated from your workplace.

Step 2. Decide with your workmates which things to put when taking into account the flow of your work. The principle is to put most frequently needed items close to the user so as to minimize the movement of the person. Things which are not so often used could not be placed slightly further away.

Step 3. It is necessary to make sure that everyone at your workplace knows what is kept for efficient use. Make a list of things with location and put it in a locker or cabinet. Label each drawer/cabinet to show what is kept inside.

Note:

The object of SEITON (SYSTEMATIZED) is to make your workplace a safe and efficient place to work in.

3. **SEISO** (SWEEP) means “Clean your workplace”. There is a very strong correlation between quality of products and cleanliness of the workplace where products are manufactured. Accordingly, SEISO (SWEEP) should be practiced every day, and sometimes, even during the day.

The following are suggested for your SEISO (SWEEP) operation:

- Do not wait until things get dirty. Clean your workplace, including machines, equipment, tools and furniture regularly so that they do not have chance to get dirty.
- Put things inside for 3 minutes every day.
- You and your workmates should be responsible for the dirty works around you. The janitors or sweepers will look after the common areas only.
- Never throw anything and make it your habit.
- Cleaning is also checking.

4. **SEIKETSU** (SANITIZE) means” Maintain high standard of housekeeping”. So as not to waste your effort, do not stop after implementing initial 3Ss.

The following are suggested for your SEIKETSU(SANITIZE) operation:

- Create a maintenance system for housekeeping. Make a schedule of cleaning for your workplace.
- Interdepartmental competition is a very effective means of sustaining and enhancing people’s interest on 5Ss.

Note:

1. Indicate the names of the persons responsible for the work area and for the machine.
2. Regular inspection and evaluation on the level of **4Ss** by each work are necessary.
3. Do not criticize poor cases, but also praise and commend good practices or good performances.

5. **SHITSUKE** (SELF-DISCIPLINE) means “Do things spontaneously without being told or ordered.” It is to make every one practice **4Ss** spontaneously and willingly as habit or way of life. There is no other way to foster such culture than practicing **4Ss** regularly until such time when everyone becomes fond of **5Ss**.

To help such corporate culture conducive to 5Ss, the following need to be emphasized:

- Treat your workplace as your own home.
- You are spending most of your “WAKING TIME” at your workplace than at home.
- Your workplace is an important place where to make income for yourself and your family.
- Make your workplace as clean and comfortable as your home.

Note:

In enhancing SHITSUKE (SELF-DISCIPLINE) of workers in a workplace, the rules of management are very important. People with managerial duties should be worthy of respect and emulation.

What can an individual gain from the 5Ss?

1. The **5Ss** makes your workplace more pleasant. In practicing **5Ss**, you have to start from discussing and agreeing what to put for efficient use by everyone. With your workmates, you have to clean the workplace. Such human relation and working environment will make you and your workplace pleasant.
2. The **5Ss** makes your work more efficient. If you have to look for something and take so much time finding it, you are not only wasting your time but also wasting your energy and moral.

On the other hand, if everything at your workplace is arranged in proper order and readily available for use; your work flow will always be very smooth. It improves not only your efficiency but also improves the rhythm of your work and the more you will enjoy it. If you have a work, better to enjoy it.

3. The **5Ss** improves your safety. A clear and tidy working environment where everything is properly placed, where clear instructions are readily available, and where no one throws anything is safer place to work in.

Practicing **5Ss** improves your own safety. You can enjoy your work more with less risk.

4. The **5Ss** improves quality of your work and your products. People affect environment. On the other hand, the environment also affects people. If you are accustomed to work in a clear and tidy environment, you can develop your sensitivity so that you can feel and identify any defect in work. On the contrary, messy and untidy environment will adversely affect your sensitivity.

Therefore, good environment will improve the quality of your work. It is quite natural that quality products come only from clean and well-organized workplace.

5. The **5Ss** makes a quality life of people. The process of **5Ss** requires people to think, consult and agree with others and cooperate with each other.

At the same time, practicing the **5Ss** gives people satisfaction of being creative, friendly with others and seeing chances better.

In summary:

- **5Ss** improves **CREATIVITY** of people
- **5Ss** improves **COMMUNICATION**
- **5Ss** improves **HUMAN RELATION** among people
- **5Ss** enhances **COMRADERSHIP** among people
- **5Ss** gives **VITALITY** to people

Vitality of the people is the locomotion to move the company forward.

A Healthy Shop Is a Safe Shop

The shop should be pleasant place where you will enjoy your work. Large manufacturing companies have learned that the shop accidents are greatly reduced when the shop itself is well-lighted and well-ventilated. The introduction of ventilating and blower systems, which free the air of dust and particles of dirt, have gone a long way toward reducing accidents. Good lighting, both natural and artificial, likewise safeguards the worker. The healthy shop is a safe shop. After all, the protection of health is the first rule of "*Safety First in the Shop*".

Safe Procedures

1. Control measures should be regularly reviewed through:
 - workplace communication and consultation;
 - safety and health committee meetings;
 - regular equipment and work safety checks;
 - incident, accident and near-miss records;
 - injury and lost time records; and
 - repair and maintenance reports
2. Workers should be continuously trained specifically on information and instruction on:
 - workplace safety and health;
 - hazards and risks associated with work activities;
 - safe work practices and procedures, safe handling (including lifting and moving), safe operation of equipment and the control measures in place;
 - safe use of plant and associated equipment, electrical safety, safety in confined spaces and other training required under hazard-specific regulations;
 - safe use of hazardous substances relevant to the work to be performed;
 - correct use, fit and care of PPE , tools and equipment and why the equipment is needed
 - ✓ emergency and first aid procedures;
 - ✓ sun protection to prevent skin cancer;
 - ✓ fire protection;
 - ✓ information on dust, fumes and air quality; and
 - ✓ recognition of poorly ventilated areas and confined spaces.



How Much Have You Learned?

Self-Check 3.1

Maintain Occupational Health and safety awareness

Directions: This part checks whether you have learned the required competencies for this particular module. Simply encircle the best answer from the choices given.

1. It is simply the application of workable principles that increases the awareness and ability of the workers to be more productive and efficient without sacrificing their safety and the product quality.
 - A. Occupational Health & Safety
 - B. Risk Management
 - C. Work Procedure
 - D. Work Simplification
2. Which primarily uses least resources in the workplace?
 - A. Occupational Health & Safety
 - B. Risk Management
 - C. Work Procedure
 - D. Work Simplification
3. What government agency is responsible primarily for setting and enforcing mandatory occupational health and safety standards through appropriate orders?
 - A. Department of Public Works and Highways
 - B. Civil Service Commission
 - C. Department of Labor and Employment
 - D. Department of Budget and Management
4. Which is NOT a PPE?
 - A. helmets
 - B. goggles
 - C. gloves
 - D. shorts
5. Which is a common hazard?
 - A. obstructions
 - B. damaged saw blades
 - C. hazardous dusts
 - D. all of the above
6. Which is a risk?
 - A. Out-of-control cutting machine
 - B. Vibration
 - C. power cords
 - D. beard, loose hair, loose clothing
7. Which is a step on risk management?
 - A. Identification of Safety Procedures
 - B. Hazard Identification
 - C. Training the Workers
 - D. All of the Above
8. Which is a control measure on accident prevention?
 - A. Workplace communication and consultation
 - B. Safety and health committee meetings
 - C. Regular equipment and work safety checks
 - D. All of the Above

9. Which is the emphasis of continuous training of the workers as hazard/risk management measure?
- A. Workplace safety and health.
 - B. Emergency and first aid procedures
 - C. Hazards and risks associated with work activities
 - D. All of the above
10. Who are covered by the Occupational Health and Safety Regulations?
- A. Employers
 - B. Workers
 - C. Self-Employed
 - D. All of the above

Refer to the Answer Key. What is your score?



How Do You Apply What You Have Learned?

Show that you learned something by doing this activity.

Activity Sheet 3.1

- I. Give what is being asked. Write your answer on your answer sheet.
- A. Explain briefly the following 5Ss:
- 1. SEIRI
 - 2. SEITON
 - 3. SEISO
 - 4. SEIKETSU
 - 5. SHITSU
- B. Cite 4 advantages of the 5Ss for the people if observed strictly?
- 1.
 - 2.
 - 3.
 - 4.
- C. Enumerate 5 reasons why schools such as yours should practice the 5Ss religiously?
- 1.
 - 2.
 - 3.
 - 4.
 - 5.

Activity Sheet 3.2

- II. List down all possible shop norms that you can think of based on the **5Ss** which will comprise your **Personal Checklist of Shop Norms**. Finalize your Personal Checklist of Shop Norms on a $\frac{1}{4}$ size illustration board which you will accomplish weekly by simply putting check marks (/) on shop norms that you perform consistently the whole week. Remember, *the check marks are representative of your practices for the week*. This checklist shall be used for the whole year. So, put your extra effort to keep it clean and in perfect condition.

Activity Sheet 3.3

- III. Group yourselves into five (5) members. Each group shall role play for 10 to 15 minutes for a certain activity that is observed in the road. Be sure to use safety signs and symbols as the group props. Presentation shall be assessed according to the given rubrics.

Activity Sheet 3.4

- IV. Group yourselves according to the class grouping to perform a **buzz session** for 20 minutes. The focus of this activity is to come up with common shop rules to prevent or minimize shop accidents due to wrong work practices. The more rules the group can craft, the better would it be for the group. Be sure that the rules determined have been written clearly on a whole sheet of butcher's paper (Manila paper). Finally, let your leader present the output to the class for discussion in order to come up with one set of rules for the entire class.

Activity Sheet 3.5

- V. This activity is a group work. Perform a pantomime for 7-10 minutes. Be sure that the scenario shall create favorable impact on the audience zeroing in the key points on industrial hazards and accidents. Performances shall be evaluated using the given rubric.



How Well Did You Perform?

Find out by accomplishing the Scoring Rubric honestly and sincerely. Remember it is your learning at stake!

III. ROLE PLAY

Scoring criteria	5 Excellent	4 Good	3 Needs Some Improvement	2 Needs Much Improvement	1 N/A
Relates to audience.					
Provides a fluent rendition of scenario.					
Role-plays scenario with feeling and expression.					
Varies intonation.					
Presents characters appropriately.					
Gives the scenario its full range.					
Breaches are easily identified.					

Scale:

30-35 A Excellent

25-29 B Good

19-24 C Needs Some Improvement

13-18 D Needs Much Improvement

7-12 F Not Appropriate

TOTAL=

Comments

IV. BUZZ SESSION

	Beginning 1 point	Developing 2 points	Accomplished 3 points	Exemplary 4 points
Contribution	One or more members do not contribute.	All members contribute, but some contribute more than others.	All members contribute equally.	All members contribute equally, and some even contribute more than was required.
Cooperation	Teacher intervention needed often to help group cooperate.	Members work well together some of the time. Some teacher intervention needed.	Members work well together most of the time.	All members work well together all of the time; assist others when needed.
On task	Team needs frequent teacher reminders to get on task.	Team is on task some of the time. Needs teacher reminders.	Team is on task most of the time. Does not need any teacher reminders.	Team is on task all of the time. Does not need any teacher reminders.
Communication	Members need frequent teacher intervention to listen to each other and speak to each other appropriately.	Members need some teacher intervention to be able to listen to each other and speak to each other appropriately.	All members listen to each other and speak to each other in equal amounts.	Each member listens well to other members. Each member speaks in friendly and encouraging tones.

V. PANTOMINE

Pantomime			Powered by iRubric
	Needs Improvement (N/A)	Developing (N/A)	Proficient (N/A)
Beginning	<p>Needs Improvement Began in a wishy washy manner, did not establish the scene's beginning confidently.</p> <p>2 3 4</p>	<p>Developing Scene began in the middle of action, but with some sense of confidence.</p> <p>5 6 7</p>	<p>Proficient Beginning was confident and executed well. The focus was strong and energy was present.</p> <p>8 9 10</p>
Story	<p>Needs Improvement The pantomime had no beginning, middle, or end. It was flat and did not take the audience through a story.</p> <p>2 3 4</p>	<p>Developing Pantomime had at least a beginning, middle, and/or end but the journey was not entirely obvious to the audience.</p> <p>5 6 7</p>	<p>Proficient Pantomime had a full storyline: beginning, middle, and end. The performance was clear in the journey of the performer.</p> <p>8 9 10</p>
Mechanics	<p>Needs Improvement The pantomime did not have any form to it. It was completely unclear as to what the pantomime was about and therefore unbelievable.</p> <p>2 3 4</p>	<p>Developing The majority of the pantomime was executed well. Most of the actions were clear and the action was understood by the audience.</p> <p>5 6 7</p>	<p>Proficient The pantomime was executed very well. All the actions were believable and therefore the overall action was clear to the audience.</p> <p>8 9 10</p>
Emotion	<p>Needs Improvement Lack of emotional connect. Flat expressions, did not change or express feelings.</p> <p>2 3 4</p>	<p>Developing Moderate emotions depicted, some change of feeling during the scene.</p> <p>5 6 7</p>	<p>Proficient Excellent use of emotion and facial expression. Conveyed a sense of character and an array of feelings.</p> <p>8 9 10</p>
TOTAL	Needs Improvement	Developing	Proficient



Congratulations! You did a great job! Rest and relax a while then move on to the next lesson. Good luck!

REFERENCES

LO1

- Morgan , Robert E , The Complete Handbook of Plumbing, TAB Books Inc., Phils. , 1962
- Oravetz , Jules Revised by Re Miller, Audel Questions and Answers for Plumbers" Examination, 3rd Edition Mac Millan Publishing Co., New York.

LO 2

- Oravetz , Jules Revised by Re Miller, Audel Questions and Answers for Plumbers" Examination, 3rd Edition Mac Millan Publishing Co., New York.
- www.google.com

LO 3

- Oravetz , Jules Revised by Re Miller, Audel Questions and Answers for Plumbers" Examination, 3rd Edition Mac Millan Publishing Co., New York.
- www.google.com

LO 4

- www.co.kern.ca.us/cao/policy/12.pdf (Accidents)
- http://images.search.yahoo.com/search/images;_ylt=A0PDoS.Q40VP2hoAbxyJzbfK?p=cooperation&fr=yfp-t-701&ei=utf-8&n=30&x=wrt&y=Search
- TESDA Handouts
- Pardinas, J. (2012). *Handout on Signs and Symbols*.

http://museumca.org/goldrush/curriculum/we_accuse/tgroupubric.html

ANSWER KEY

Lesson 1

LO1. (Self-Check 1-1)

USES

1. Construction/Carpentry
2. Construction/ Carpentry
3. Construction/ Carpentry
4. Construction/ Carpentry
5. Construction/ Carpentry
6. Construction/ Carpentry
7. Construction/ Carpentry
8. Construction/ Carpentry
9. Construction/ Carpentry
10. Construction/ Carpentry

1. Cutting
2. Testing
3. Testing
4. Testing
5. Driving
6. Paring/Cutting
7. Smoothing
8. Boring
9. Sharpening
10. Finishing

LO 1. Self-Check 1.2

1. Plywood
2. Nails
3. Cement
4. Sand
5. Lumber
6. Pull-push rule
7. Claw hammer
8. Rip saw
9. Plumb-bob
10. Try-square
11. Liter
12. Piece
13. P20.00
14. P1040.00

LO 2. Self-Check 2-1

1. 1 Pc $\frac{3}{4}$ Plywood P 70.00
2. 1 Liter Wood Stain (Maple) P110.00
3. 1 Kl. 1 $\frac{1}{2}$ Finishing Nails P 75.00
4. 2 pcs. 180 Sandpaper P 30.00
5. 2 pcs. 200 Sandpaper P 30.00
6. 1 Liter Blackboard Paint QDE
Boysen Green P 120.00
7. 2 Bottles Paint Thinner P 50.00
8. 2 pcs. Paint Brush P 50.00

LO 2. Self-Check 2-2

1. Description
2. Piece
3. P700.00
4. kilo
5. P30.00
6. 1
7. Foot
8. 1
9. P150.00
10. 1

LO 3 Self-Check 3-1

1. /
2. /
3. X
4. /
5. /
6. X
7. /

PRE-TEST 1.1

1. B.
2. A.
3. CLAW HAMMER, CROSS-CUT SAW, SCREW DRIVER...
4. LUMBER, PLYWOOD, STEEL BARS...
5. NAILS, SCREW...

LESSON 2

Pretest LO 1

A.

1. Driving tool
2. Holding tool
3. Edge Cutting Tool
4. Testing Tool
5. Tooth Cutting Tool
6. Measuring Tool
7. Lining Tool
8. Miscellaneous
9. Finishing material
10. Hardware

B.

1. Spoke Shave
2. Sanding Sealer
3. Compass
4. Steel Square
5. Filler
6. Auger Brace
7. Lubricant
8. Varnish
9. Rip Saw
10. Triangular File

PRE-TEST LO 2

A.

1. Driving tool
2. Holding tool
3. Edge Cutting Tool
4. Testing Tool
5. Tooth Cutting Tool
6. Measuring Tool
7. Lining Tool
8. Miscellaneous
9. Finishing material
10. Hardware

B.

1. Spoke Shave
2. Sanding Sealer
3. Compass
4. Steel Square
5. Filler
6. Brace
7. Lubricant
8. Varnish
9. Rip Saw
10. Triangular File

LESSON 3

LO1. Pre-Test

1. Pull Push Rule
2. Zigzag rule
3. Ruler
4. Clamp
5. Try Square

Self-check 1.1

1. Pull Push Rule
2. Zigzag Rule
3. Ruler
4. Caliper
5. Try Square
6. Meter Stick
7. Divider
8. Compass
9. Protractor

A. DO'S

5. Measuring tools / instruments must be wiped before returning them to the storage room.
6. Oil the movable parts of the measuring tools such as zigzag rules, calipers, dividers and compasses to avoid stock-up.
7. Make sure that grits like sand will not get inside the housing or case of a pull-push rule to avoid wearing off of the graduations.
8. Check the lock of a pull-push rule if it is working

B. DON'T'S

4. Do not wipe off edges of the steel tape of pull-push rule with bare hands to avoid injury.
5. Do not pull the steel tape of pull-push rule too much to avoid the coil spring from damage.
6. Do not use the caliper as tongs.

6 Faces of a Lumber

1. 2 ends
2. 2 edges
3. 2 surfaces

3 measurements obtained from 6 faces of lumber

1. Length
2. Width
3. Thickness/Height

LO.2

Self-Check 2.1

- I. 1-2. English and Metric System
3-5. Yard, Foot, Inch
6-9. Meter, Decimeter, Centimeter, Millimeter
- II.
 1. $\frac{3}{8}$ inches
 2. $\frac{13}{16}$ inches
 3. $1\frac{1}{4}$ inches
 4. $1\frac{1}{2}$ inches
 5. $1\frac{11}{16}$ inches
 6. 2 cm
 7. 15 mm
 8. 28 mm
 9. 36 mm
 10. 4cm
- III.
 1. 0.25
 2. 0.75
 3. 0.625
 4. 0.875
 5. 0.5625
 6. 2.2
 7. 3.25
 8. 1.8
 9. 6.6
 10. 3.67
- IV.
 1. 400cm
 2. 13.12ft.
 3. 96 inches
 4. 50.8 cm
 5. 6 meters
- V.
 1. Measure end to end of stock with a tool
 2. Measure edge to edge with a tool
 3. Measure outside diameter of a cylindrical object using a caliper
 4. Measure inside diameter with a caliper
 5. Lay-out width

Self-Check 2.2

1. 12 bdf.
2. 10 bdf.
3. 5.33 bdf.
4. 24 bdf.
5. 16 bdf.

LESSON 4

LO1. Pre-Test

1. Dimension line
2. Leader line
3. Reference line
4. Limiting line
5. Projection line
6. Center line
7. Hidden/visible line
8. Boarder line
9. Visible line
10. Cutting plane line

LO2

A. COMPONENTS

- Legs - 4pcs. 45mm x45mmx500mm wood (tanguile)
Short rails - 2pcs. 25mm x70mm x600mm (tanguile)
Long rails - 2pcs. X25mm x70mm x800mm (tanguile)
Top board - 1pc. 25 mmx600mm x800mm (plyboard / Plywood)

B. ASSEMBLIES JOINTS

Mortise and tenon joint- The joint used in joining the rails and legs of the center table

C. Dimensions and specifications

1. All dimensions must be in millimeters.
2. Wood to be used must be tanguile.
3. All joints must be filled with glue.
4. Legs must be tapered

Materials:

- 4pcs - 45mm X 45mm X 500mm
- 2pcs - 25mm X 70mm X 600mm -Tanguile
- 2pcs - 25mm X 70mm X 800mm
- 1pcs - 25mm X mm X 800mm – Plyboard / Plywood
- 40pcs 1 ½ finishing mails
- wood glue
- wood filler
- sand paper

Tools and Equipment

10. Pencil
11. Pull push rule/ zigzag rule
12. Marking gauge
13. Try Square
14. Carpenter Square
15. Cross Cut saw / Back Saw
16. Jack plane/ Smooth Plane
17. Claw Hammer

- 18. Wooden Mallet
- 10. Mortise Chisel
- 11. Nail Set
- 12. Working Bench
- 13. Hand Screw Clamp
- 14. Bar Clamp
- 15. Bench Vise
- 16. Pattern or Jig
- 17. Portable planer (Optional)

LO3

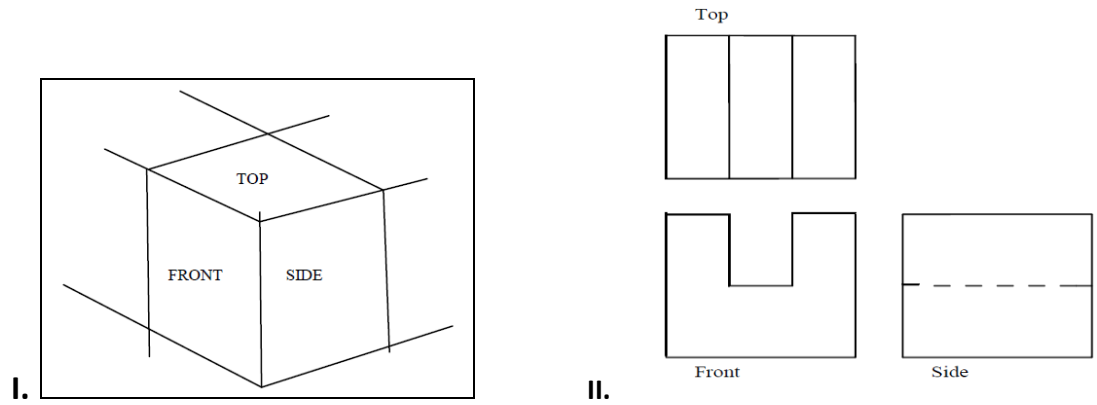

PRE-TEST

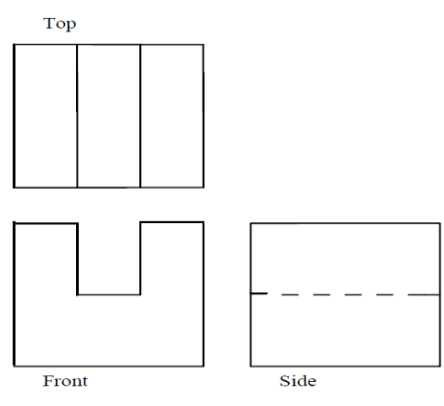

Lesson 5

PRE-TEST

LO 1

- 1.D
- 2.A

LO 2

- 1.gloves
- 2.goggles

3.D	3.safety cap
4.A	4.ear muffs
5.A	5.safety shoes

LO 3

1.D
2.C
3.D
4.D
5.B

LO 4

1.C 6.D
2.B 7.A
3.C 8.C
4.B 9.A
5.D 10. D

SELF-CHECK

LO 1

1.A
2.C
3.D
4.C
5.C

LO 3

1.D
2.C
3.D
4.D
5.B

LO 4

1.A 6.D
2.D 7.D
3.C 8.D
4.D 9.A
5.D 10.B

LO 2

1. **Danger Signs** - are used only where immediate hazards exist. They are printed in red as the predominating color.
3. **Caution Signs** - are used to warn against potential hazards.
4. **Exit Signs** - are printed in legible red letters for exits.
5. **Accidental Prevention Tags** - are used as temporary means of warning to existing hazards, such as defection, tools and equipment.

Acknowledgement

This Learning Module was developed for the Exploratory Courses in Technology and Livelihood Education, Grades 7 and 8 of the K to 12 Curriculum with the assistance of the following persons:

This Learning Module on **CARPENTRY** was developed by the following personnel:

MODULE WRITERS

FELY L. MANUEL, Ph. D.
Head Teacher III Officer-In-Charge
Cabarroguis National School of Arts and
Trades
Division of Quirino, Region 02

ORLANDO E. MANUEL, Ph. D.
Officer-In-Charge, Assistant Schools Division
Superintendent
Division of Quirino, Region 02

REVIEWERS

GIL P. CASUGA
Chief TESD Specialist

REYNALDO S. DANTES
Senior TESD Specialist

BERNADETTE S. AUDIJE
Senior TESD Specialist

MARIA A. ROQUE
Senior TESD Specialist

AIDA T. GALURA
VSA II, ACNTS

VICTORIO N. MEDRANO
Principal IV, SPRCNHS

PARALUMAN R. GIRON, Ed.D.
Chair, Sub-TWG on K to 10

BRENDA B. CORPUZ, Ph.D.
TA for K to 12 Curriculum

OFELIA O. FLOJO
Retired Assistant Chief, EED, Region IV-A

RODERICK AGUIRRE. Ph.D.

BEATRIZ A. ADRIANO
Principal IV, ERVHS

DOMINGA CAROLINA F. CHAVEZ
Principal II, MBHS

DOCUMENTORS / SECRETARIAT

PRISCILLA E. ONG
K to 12 Secretariat

FREDERICK G. DEL ROSARIO
Head Teacher III, BNAHS

EMMANUEL V. DIONISIO
Head Teacher III, AFGBMTS

LYMWEL P. LOPEZ
Teacher I, AFGBMTS

DANTE D. VERMON JR.
Teacher I, AFGBMTS

CHERLYN F. DE LUNA
Teacher I, AFGBMTS

LOUIE B. ANGELES
Teacher I, BNAHS

JOANNA LISA C. CARPIO
Teacher I, BNAHS

Dir. IMELDA B. TAGANAS

Executive Director, Qualifications Standards Office
K to 12 Learning Area Team Convenor, TLE/TVE

