



Republic of the Philippines  
**DEPARTMENT OF EDUCATION**



# **K to 12 Basic Education Curriculum Technology and Livelihood Education Learning Module**



# **CONSUMER ELECTRONICS SERVICING**

*EXPLORATORY COURSE*

*Grade 7 and Grade 8*

## TABLE OF CONTENTS

What Is This Module About ? .....	2
How Do You Use This Module .....	3
<b>LESSON 1 – Use Hand Tools</b> .....	4-22
<b>LESSON 2 – Perform Mensuration and Calculation</b> .....	23-53
<b>LESSON 3 – Prepare and Interpret Technical Drawings</b> .....	54-100
<b>LESSON 4 – Practice Occupational Safety and Health</b> .....	101-125
<b>LESSON 5 – Maintain Tools and Equipment</b> .....	126-143
Answer Keys .....	144-151
Acknowledgment.....	152



## What Is This Module About?

Welcome to the world of **Consumer Electronics Servicing!**

This Module is an exploratory course which leads you to **Consumer Electronics Servicing** National Certificate Level II (NC II)<sup>1</sup>. It covers five common competencies that a Grade 7 / Grade 8 Technology and Livelihood Education (TLE) student like you ought to possess, namely:

- 1) Use Hand Tools;
- 2) Perform Mensuration and Calculation;
- 3) Prepare and Interpret Technical Drawings;
- 4) Practice Occupational Safety and Health; and
- 5) Maintain Tools and Equipment

These **five** common competencies are covered separately in five lessons. As shown below, each lesson is directed to the attainment of one or three learning outcomes:

### Lesson 1 – **Use Hand Tools**

LO1. Prepare hand tools

LO 2. Use appropriate hand tools and test equipment

### Lesson 2 – **Perform Mensuration and Calculations**

LO 1. Select measuring instruments

LO 2. Carry out measurements and calculations

LO 3. Maintain measuring instruments

### Lesson 3 – **Prepare and Interpret Technical Drawings**

LO1. Identify different kinds of technical drawings

LO2. Interpret technical drawing

LO3. Prepare/Make changes in electrical/electronic schematics and diagrams

### Lesson 4 – **Practice Occupational Health and Safety**

LO 1. Identify health hazards and occupational risks

LO 2. Observe occupational and safety practices

### Lesson 5 – **Maintain Tools and Equipment**

LO 1. Maintain hand tools and equipment

LO 2. Perform basic preventive maintenance of electronic tools and equipment

Your success in this exploratory course on **Consumer Electronics Servicing** can be seen in your ability to do the performance standards found in each lesson.

---

<sup>1</sup>NATIONAL CERTIFICATE (NC) is a certification issued to individuals who achieved all the required units of competency for a national qualification as defined under the Training Regulations. NCs are aligned to specific levels within the PTQF. (TESDA Board Resolution No. 2004-13, Training Regulations Framework)

NATIONAL CERTIFICATE LEVEL refers to the four (4) qualification levels defined in the Philippine TVET Qualifications Framework (PTQF) where the worker with:

a. NC I performs a routine and predictable tasks; has little judgment; and, works under supervision;

b. NC II performs prescribed range of functions involving known routines and procedures; has limited choice and complexity of functions, and has little accountability;



## How Do You Use This Module?

This Module has five Lessons. Each Lesson has the following parts:

- Learning Outcomes
- Performance Standards
- Materials/Resources
- Definition of Terms
- What Do You Already Know?
- What Do You Need to Know?
- How Much Have You Learned?
- How Do You Apply What You Have Learned?
- How Well Did You Perform?
- References

To get the most from this Module, you need to do the following:

1. Begin by reading and understanding the Learning Outcome/s and Performance Standards. These will tell you what you should know and be able to do at the end of this Module.
2. Find out what you already know by taking the Pretest then check your answer against the Answer Key. If you get 99 to 100% of the items correctly, you may proceed to the next Lesson. This means that you need not go through the Lesson because you already know what it is about. If you fail to get 99 to 100% correctly, go through the Lesson again and review especially those items which you failed to get.
3. Do the required Learning Activities. They begin with one or more Information Sheets. An Information Sheet contains important notes or basic information that you need to know.  
After reading the Information Sheet, test yourself on how much you have learned by means of the Self-check. Refer to the Answer Key for correction. Do not hesitate to go back to the Information Sheet when you do not get all test items correctly. This will ensure your mastery of basic information.
4. Demonstrate what you learned by doing what the Activity / Operation / Job Sheet directs you to do.
5. You must be able to apply what you have learned in another activity or in a real life situation.
6. Accomplish the Scoring Rubrics for you to know how well you performed.

Each Lesson also provides you with references and definition of key terms for your guide. They can be of great help. Use them fully.



If you have questions, ask your teacher for assistance.

# LESSON 1

## Use Hand Tools



### LEARNING OUTCOMES:

At the end of this Lesson, you are expected to do the following:

- LO 1. prepare hand tools; and
- LO 2. use appropriate hand tools and test equipment.



## Definition of Terms

- Accidental** - occurring unexpectedly, unintentionally, or by chance.
- Alternating current** - an electric current that is continually varying in value and reversing its direction of flow at regular interval
- Anode** - a positive electrode of semiconductor device
- Capacitance** - a property that exists whenever two conductors are separated by insulating material, permitting the storage of electricity
- Capacitor** - a component designed intentionally to have a definite amount of capacitance
- Circuit** - an arrangement of one or more complete paths of electron flow.
- Conductor** - a wire, cable, or other body or medium that is suitable for carrying electric current
- Current** - the rate of transfer of electricity from one point to another
- Desoldering** - a process of unsoldering unwanted parts or components in the circuit with the support of a soldering tool
- Dielectric material** - a material that serves as insulator because it has poor electric conductivity
- Direct current** - an electric current that flows in one direction
- Discrete components**- separated or individual components
- Electronics** - a branch of science and technology that deals with the controlled flow of electrons
- Flammable** - tending to burn quickly
- Hazards** - risks; dangers
- Malfunction** - not in normal operating condition
- Ohmmeter** - an instrument that measures the amount of resistance in certain component or circuits
- Resistance** - the opposition that a component or material offers to the flow current
- Resistor** – a component designed intentionally to have a definite amount of resistance
- Soldering** - a process of joining two metals caused by heat
- Soldering technique** - a strategy in which the solder (lead) is being applied in a connection or in the printed circuit board
- Splicing** – connecting two lengths of conductor
- Technician** - a person skilled in mechanical or industrial techniques or in a particular technical field
- Tool kit** - a small bag or box equipped with hand tools
- Troubleshooting** - identifying and repairing faults in equipment
- Voltage** - the electrical pressure that exist between two points and capable of producing a flow of current when a close circuit is connected between the points.
- Voltmeter** - an instrument that measures the amount of electromotive force in a component or circuit.

## Acronyms

- PCB** – Printed Circuit Board  
**PPE** – Personal Protective Equipment  
**VOM** – Volt-Ohm-Milliameter

## LEARNING OUTCOME 1

### Prepare Hand Tools

#### PERFORMANCE STANDARDS

- Appropriate hand tools are identified.
- Appropriate tools are selected according to task requirements.



### What Do You Already Know?

Let us determine how much you already know about the different hand tools. Take this test.

Pretest LO 1

**Directions:** Match the different hand tools with their actual pictures. Write the letter of your answer on a separate sheet.

1. Desoldering tool
2. Soldering iron
3. Soldering stand
4. Long nose pliers
5. Portable electric drill
6. Paint brush
7. Hacksaw
8. Side-cutter
9. Wire splicer
10. Magnifying glass

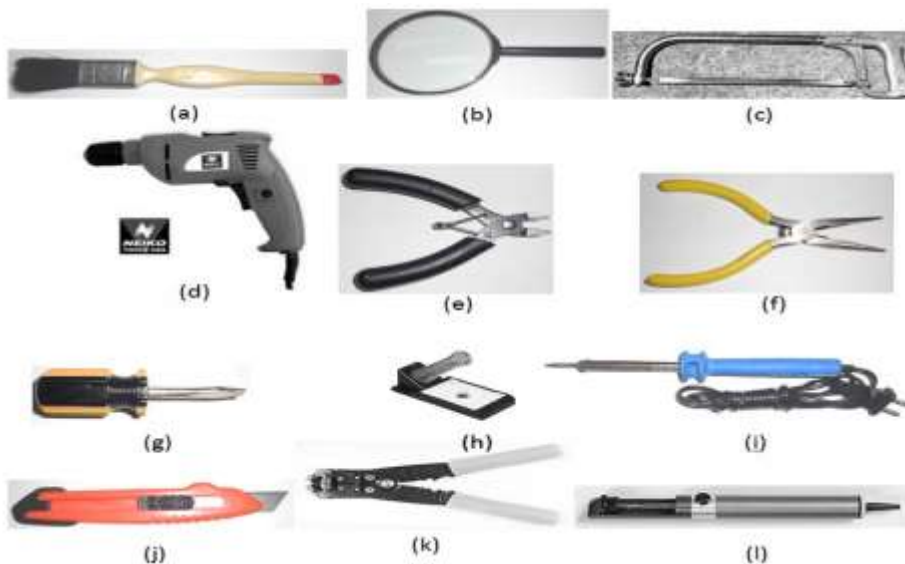



## What Do You Need To Know?

Read Information Sheet 1.1 very well; then, find out how much you can remember and how much you have learned by answering the Self-check.

Information Sheet 1.1

### Basic Hand Tools

#### Driving of Tools

1. **Screwdrivers** are hand tools specifically designed to insert and tighten, or to loosen and remove screws. A screwdriver comprises a head or tip, which engages with a screw; a mechanism to apply force by rotating the tip, and some way to position and support the screwdriver, the tip of which is shaped to fit a particular type of screw.



- a. **Slotted Screwdriver** is used to drive or fasten negative slotted screws.



- b. **Phillips Screwdriver** – is used to drive or fasten positive slotted screws. It is a screwdriver that could take greater torque and could provide tighter fastenings.





- c. **Jeweler's Screwdriver Set** – is a set of small screw drivers composed of slotted and Phillips screwdrivers.

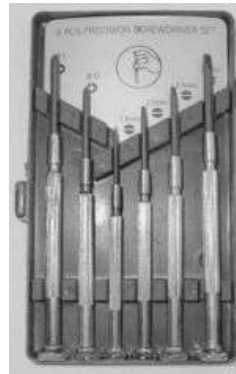

## Soldering Tools

1. **Soldering Iron** – is a device for applying heat to melt solder in attaching two metal parts. A soldering iron is composed of a heated metal tip and an insulated handle. For electrical work, wires are usually soldered to printed circuit boards, other wires, or small terminals. A low-power iron (20-30 Watts) is suitable for this work.



2. **Soldering Tool Stand** – is a place where the soldering iron is placed during usage. This will keep the soldering iron away from flammable materials. The stand often comes with a sponge used in cleaning the tip of the soldering iron.



3. **Desoldering tool** is used in removing soldered wires and components on printed circuit boards for troubleshooting and repair purposes.



## Splicing Tools

1. **Long Nose** is used for holding, bending, and stretching the lead of electronic component or connecting wires.



2. **Side Cutter** is a wire-cutting pliers, though they are not used to grab or turn anything, but are used to cut wires.



3. **Wire Stripper** is a pair of opposing blades much like scissors or wire cutters. The addition of a center notch makes it easier to cut the insulation without cutting the wire.

**Notch**



## Boring Tools

1. **12V Mini-Drill** – is used to bore or drill holes in the printed circuit board (PCB) with sizes from 1/32" – 1/16".



2. **Portable Electric Drill** is used for boring hole(s) in plastic or metal chassis with the use of drill bits having sizes from 1/6" to approximately 1/4".



3. **Metal Files** These are hand tools having a series of sharp, parallel ridges or teeth. Most files have a narrow, pointed tang at one end to which a handle can be fitted.
- **Flat File** is parallel in width and tapered in thickness; they are used for flat surfaces and edges.
  - **Half Round File** is tapered in width and thickness, coming to a point, and is narrower than a standard half round and used for filing inside of rings.
  - **Round File** - is also called rat-tail file which is gradually tapered and used for many tasks that require a round tool, such as enlarging round holes or cutting a scalloped edge.



## Cutting Tools

1. **Utility Knife** is a common tool used in cutting various trades and crafts for a variety of purposes.



2. **Hacksaw** is used for cutting metals. Some have pistol grips which keep the hacksaw firm and easy to grip. The small hand-held hacksaws consist of a metal arch with a handle that fits around a narrow, rigid blade.



## Auxiliary Tools

1. **Magnifying Glass** is a convex lens which is used to produce a magnified image of an object. The lens is usually mounted on a frame with a handle. Roger Bacon is the original inventor of the magnifying glass. A magnifying glass works by creating a magnified virtual image of an object behind the lens. Some magnifying glasses are foldable with built-in light.



2. **Paint Brush** – is a type of brush made of bristles set in handle, used for cleaning dirty parts of a circuit or an object aside from using it for painting.



## Electronic equipment

Aside from hand tools, other types of equipment are also needed for more accurate and quality output. Three of the most used equipment are presented here for you to be familiar with their uses and the proper way of maintaining them.

- a. Volt-Ohm-Milliammeter. It is an equipment that combines three functions: as a voltmeter that measures both ac and dc voltages; an ohmmeter that measures resistance; and milliammeter that measures small amount of dc current. As safety precautions in the maintenance of this instrument, the following should be observed:
  - Always rest the function switch at 250V AC if an OFF position is not available in the instrument.
  - For current and voltage measurements, always set the function switch in the correct setting which is a little higher than the expected current or voltage present in the circuit.
  - Place the instrument in a cool dry place, away from any magnetic devices, and free from vibrations.



Volt-Ohm-Milliammeter



Oscilloscope



Signal generator

- b. Oscilloscope. An oscilloscope (commonly abbreviated CRO, for cathode-ray oscilloscope, or scope) is a piece of electronic test equipment that allows signal voltages to be viewed, usually as a two-dimensional graph of one or more electrical potential differences (vertical axis) plotted as a function of time or of some other voltage (horizontal axis).
- c. Signal generator. A signal generator is a device which produces simple wave forms.

Such devices contain an electronic oscillator, a circuit that is capable of creating a repetitive waveform. These are typically used in simple electronics repair and design where they are used to stimulate a circuit under test.

Oscilloscope and signal generator should be given regular checkup for at least once a week by connecting them to the power line. This will help prevent their components from having moisture that might cause trouble in their circuits.

In any activity involving skills, it is a standard procedure that you must always use the right tool or equipment properly needed for particular task. However, despite

this reminder or caution, some students abuse the use of tools. The following are common faults that must be avoided:

### **Common Faults in Using Hand Tools**

#### **Pliers:**

- Do not increase the handle length of pliers to gain more leverage. Use a larger pair of pliers or bolt cutters if necessary.
- Do not substitute pliers for a wrench when turning bolts and nuts. Pliers cannot grip these items properly and might cause a slip and create an accident.
- Never use pliers as a hammer on the handle. Such abuse is likely to result in cracks or breaks.
- Cut hardened wires only with pliers designed for that purpose.
- Always cut the wires in right angle. Never rock from side to side or bend wire back and forth against the cutting edges.

#### **Screwdrivers:**

- Never use screwdrivers as a pry bar, chisel, and punch stirrer or scraper.
- Never use screwdrivers with broken or worn-out handles. Screwdrivers of these kinds should have tags to indicate that they are defective.
- Never use pliers on a screwdriver for extra leverage. Only use wrench or screwdrivers specifically designed for purpose.

#### **Utility Knives/ Blades:**

- Do not use dull blades because they require more force, thus are more likely to slip. Replace the blade when it starts to “tear” instead of cut.
- Never leave a knife unattended with the blade exposed.
- Don’t bend or apply side loads to blades by using them to open cans or loosen tight cover of containers. Blades are brittle and can snap easily.



## How Much Have You Learned?

### Self-Check 1.1

**Directions:** On a separate piece of paper, classify the different kinds of hand tools according to their specification in Consumer Electronics Servicing.

Hand tools	Classification
1. Desoldering Tool	
2 Wire Splicer	
3. Side Cutter	
4 Long Nose Pliers	
5 Mini Drill	
6 Magnifying Glass	
7 Soldering Stand	
8 Screwdriver	
9 Soldering Iron	
10. Portable Electric Drill	

### Self-Check 1.2

Directions: Answer briefly the questions below.

1. Why is a low-power soldering iron suitable for electronic work?
2. What are the advantages of using a magnifying glass that is foldable with built-in light?
3. Why is it best to use the right size of Phillips-type screwdriver?
4. Why is it best to use the right size of drill bit in boring holes?
5. Why do you think is it best for a soldering iron to have its soldering stand?

**Refer to the Answer Key. What is your score?**

## LEARNING OUTCOME 2

### Use Appropriate Hand tools and Test Equipment

#### PERFORMANCE STANDARDS

- Tools are used according to task undertaken.
- All safety procedures in using tools are observed at all times.
- Malfunctions, unplanned or unusual events are reported to the supervisor.



### What Do You Already Know?

**Determine how much you already know about using appropriate hand tools and test equipment. Take this test.**

Pretest LO 2

**Direction:** Multiple Choice: Choose the best answer. Write letters only.

1. Which equipment does NOT belong to the group?
  - a. Screw driver
  - b. Long nose pliers
  - c. Diagonal cutter
  - d. Side cutting
2. What is the reason why threads become stripped?
  - a. Screws are over tightened
  - b. Screws are heated
  - c. Screws are molded
  - d. Screws are painted
3. What equipment is/are used for safety?
  - a. VOM
  - b. PPE
  - c. OHS
  - d. All of those mentioned
4. Which is NOT part of the group?
  - a. Soldering iron
  - b. Desoldering tool
  - c. Soldering tool stand
  - d. Wire stripper
5. Which hand tool is used solely for cutting metals?
  - a. Utility knife
  - b. Saw
  - c. Magnifying glass
  - d. Paint brush





## What Do You Need To Know?

**Read Information Sheet 2.1 very well. Then find out how much you can remember and how much you learned by answering the Self-check.**

### Information Sheet 2.1

## USING TOOLS BASED ON THEIR FUNCTIONS AND OPERATION

Whenever you perform a task in the workshop you must use personal protective clothing and equipment (PPE) that are appropriate for the task and which conforms with your local safety regulations and policies.

Your skill in using tools and equipment will make your work less difficult and ensure that tasks are performed properly and safely.

- Hand Tools
  - screwdrivers, needle-nose pliers
- Diagnostic Tools
  - Analog or digital Volt-Ohm-Milliammeter, power supply

### Safety check

- Do not use flammable cleaners or water on electrical equipment.
- Make sure designated walkways are kept clear of any obstructions.
- Always wear protective clothing and use the appropriate safety equipment.
- Make sure that you understand and observe all legislative and personal safety procedures when carrying out the following tasks.

### Proper Use of Hand Tools

- Use the proper type and size of screwdriver by matching it to the screw.
- Phillips and Flat Head are the most common types.
- Do not over tighten screws because the threads may become stripped.

In many types of work, hand tools are used every day. They make work easier and allow people to be more efficient. However, majority of students often fail to see the hazards these tools can introduce. In this module "Hand Tool Safety" shows workers how accidents can be significantly reduced by reviewing the various hazards that are associated with specific types of tools.



## How Much Have You Learned?

### Self-check 2.1

**Direction:** Match Column A with Column B

- | A   | B                   |
|---|---------------------|
| 1. Cut the insulation without cutting the wire                              | a. Screwdriver      |
| 2. Drill holes in the printed circuit board                                 | b. Long nose        |
| 3. Tighten, loosen or remove screws   | c. Wire stripper    |
| 4. Remove soldered wires  | d. 12 V Mini-drill  |
| 5. Hold, bend, stretch the lead of electronic component or connecting wires | e. Desoldering tool |
| 6. Cut metals   | f. Paint brush      |
| 7. Clean dirty parts of an object   | g. Hacksaw          |
| 8. Produce a magnified image of an object                                   | h. Signal generator |
|   | i. Magnifying glass |

**Refer to the Answer Key. What is your score?**



## How Do You Apply What You Have Learned?

Show that you have learned something by doing this activity.

Operation Sheet 2.1

### Instruction:

1. Do the following Operation Sheets:
  - a. Procedure in using a soldering iron
  - b. Mounting and soldering of components on PCB
  - c. Disassembly and assembly of the circuit

#### **Procedure in using a soldering iron**

1. Preparing the soldering iron
  - a. Place the soldering iron on the stand before plugging it.
  - b. Wait a few minutes for the soldering iron to attain its operating temperature of about 400°C.
  - c. Wipe the tip of the soldering iron on the wet damp sponge
  - d. Melt a little solder (soldering lead – 60/40) on the tip of the iron.
  - e. Wipe again the tip of the soldering iron on the wet damp sponge.
2. Soldering technique
  - a. Hold the soldering iron like a pen, near the base of the handle.
  - b. Touch the soldering iron onto the joint to be soldered.
  - c. Apply a small amount of solder onto the joint.
  - d. Remove the solder, then the soldering iron, while keeping the joint in still position.
  - e. Inspect the joint closely. It should look shiny and in a volcano shape.

**Mounting and soldering of components on PCB**

**Procedure in mounting and soldering components on printed circuit board**

1. Carefully check the ready-made PCB against the diagram and inspect for any microscopic shorts or open paths. Do the remedial steps, if necessary.
2. Insert the two 33K, ¼-watt resistors as indicated in the diagram.
3. Insert the two electrolytic capacitors in the PCB as shown in the diagram. Take note of their polarity orientation.
4. Mount the two NPN transistors in the PCB taking into consideration the proper orientation of their electrodes (emitter, base, and collector).
5. Mount the two jumbo LEDs (Light-Emitting-Diodes) to the place intended for in the PCB.
6. Remove the insulation of a 4-inch #22 black stranded hook-up wire with at least 1/8 of an inch on both ends. Insert the uninsulated part at one end for the negative supply.
7. Do the same as in step no. 6 using red hook-up wire for the positive supply.
8. Let your work be checked by your teacher before making any soldering job.
  - a. Solder the connections of your work following the procedure of proper soldering technique.

**Diagram and components of the blinker**

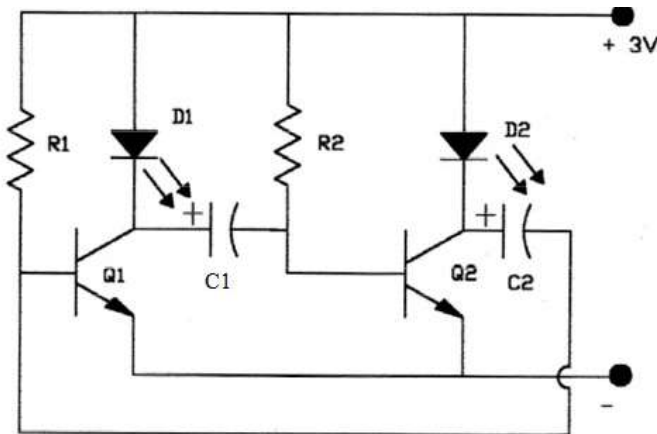

Components' values	
R1, R2	= 33K, 1/4W
C1, C2	= 33µF, 16VDC
Q1, Q2	= 2SC828
D1, D2	= jumbo LED

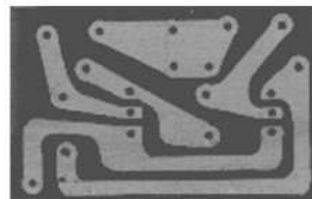
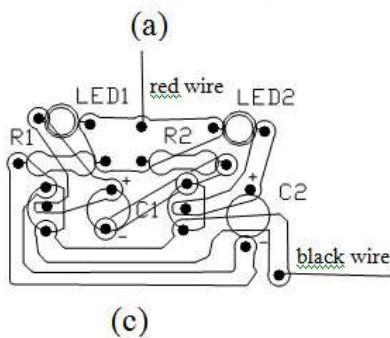

Blinker circuit. (a) Schematic diagram (b) Parts list (c) Components' lay out (top view) (d) Foil pattern on PCB (bottom view)

## **Disassembly and assembly of the circuit**

### **Desoldering**

At some stage, you will probably need to desolder a joint to remove or re-position a wire or component. The easiest and most common way is the use of desoldering pump. Shown below is the proper way of removing electronic components from the circuit using a desoldering tool.



### **Removing components in PCB using a desoldering pump (solder sucker)**

1. Set the pump by pushing the spring-loaded plunger down until it locks.
2. Apply both the pump nozzle and the tip of your soldering iron to the joint.
3. Wait a second or two for the solder to melt.
4. Then press the button on the pump to release the plunger and suck the molten solder into the tool.
5. Repeat if necessary to remove as much solder as possible.
6. The pump will need emptying occasionally by unscrewing the nozzle.

After removing most of the solder from the joint(s), you may be able to remove the wire or component lead straight away (allow a few seconds for it to cool). If the joint does not come apart easily, apply your soldering iron to melt the remaining traces of solder, at the same time pulling the joint apart, taking care to avoid burning yourself.

Be careful in desoldering to be sure that no component is damaged during the process.



## How Well Did You Perform?

Find out by accomplishing the Scoring Rubric honestly and sincerely.  
Remember it is your learning at stake!

### 2.1 Procedure in using a soldering iron

**Direction:** Prepare an actual laboratory activity regarding soldering techniques.

**Suggested Activity:**

Construct a figure or image using #18 solid copper wire applying proper soldering techniques.

Procedure in using a soldering iron									
Item no.	Soldering Tool	70	75	80	85	90	95	100	Score
A	Proper use of tool - 50%								
B	Quality of work - 40%								
C	Speed – 10%								
<b>Grade</b>									

### 2.2 Mounting and soldering of components on PCB

**Direction:** Students will be guided in mounting and soldering the components of the blinker circuit on PCB applying proper soldering techniques.

Mounting and soldering of components on PCB									
Item no.	Soldering Tool	70	75	80	85	90	95	100	Score
A	Proper use of tool - 50%								
B	Quality of work - 40%								
C	Speed – 10%								
<b>Grade</b>									

### 2.3 Disassembly and assembly of the circuit

**Direction:** Your teacher will guide you in removing or desoldering the components of the blinker circuit on PCB applying proper desoldering procedure.

Disassembly and assembly of the circuit									
Item no.	Soldering Tool	70	75	80	85	90	95	100	Score
A	Proper use of tool - 50%								
B	Quality of work - 40%								
C	Speed – 10%								
<b>Grade</b>									



**Congratulations! You did a great job! Rest and relax a while then move on to the next lesson. Good luck!**

#### REFERENCES

- Tan, Michael Q.; Gantalao, Fred T.; Lasala, Rommel M. Simple Electronics; Andes Mountain Printers; 2004
- Enriquez, Marcelo T., Electronics Technology IV; Souvenir Publications, Inc. 2003
- Grob, Bernard, Basic Electronics, 4<sup>th</sup> Edition; New York: McGraw-Hill Company, USA: 1982

## LESSON 2

### Perform Mensuration and Calculations

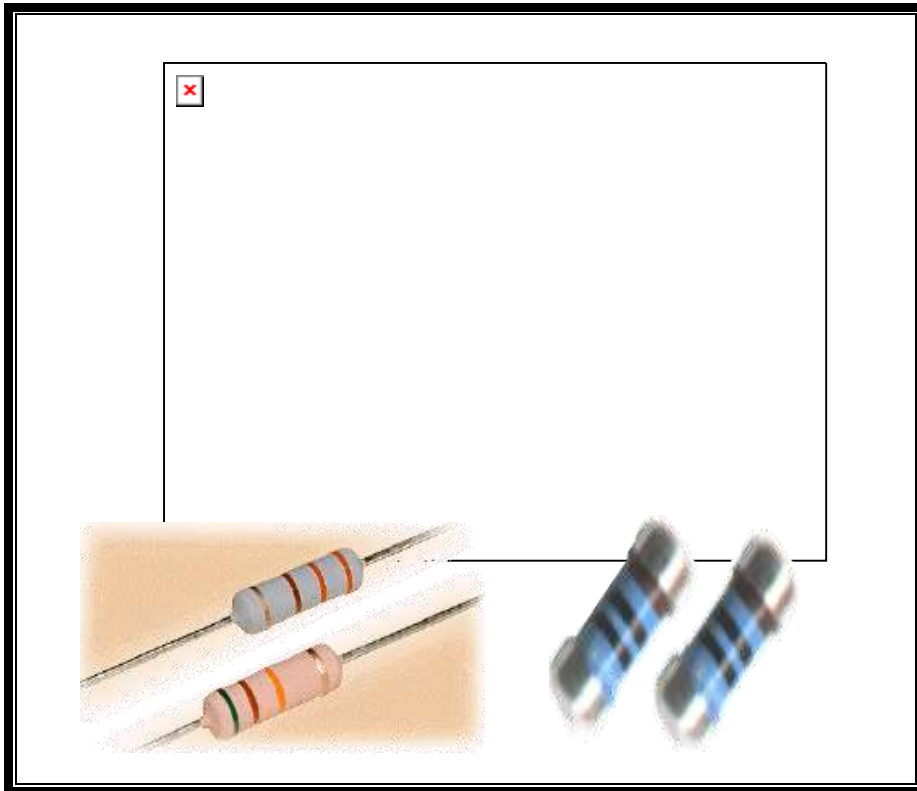

#### LEARNING OUTCOMES:

At the end of this Lesson, you are expected to do the following:

- LO 1. select measuring instruments;
- LO 2. carry out measurements and calculations; and
- LO 3. maintain measuring instruments.





## Definition of Terms

**Ampere** - basic unit of current

**Current** - the flow of electrons moving in a given direction

**Electronic measuring instrument** – a portable instrument used to measure electrical quantities such as current, voltage, and resistance

**Ohmmeter** - an electronic instrument used to measure resistance of a component or the entire circuit

**Ohmmeter scale** - section of the ohmmeter where the value of the resistance is being indicated

**Range multiplier** - a portion in the ohmmeter where the actual reading is multiplied by the range value

**Resistance** - the opposition to the flow of electrons

**Resistor** - an electronic component that is used to offer opposition to current in an electrical circuit

**Resistor color coding** - a scheme to determine the value of resistors by color bands printed on their bodies as code

**Test Probes** - connectors connected to terminals of the VOM and component's terminals or test points in a circuit to be tested. They are oftentimes red and black in color

**Tolerance** - the fourth color in the 3-band color coding that indicates the percentage of deviation from its color coded value

**Volt** - basic unit of voltage

**Voltage** - an electrical pressure that pushes current to flow within a load through a conductor

**Zero-ohm adjuster** - part of the ohmmeter that is used in adjusting the pointer of the ohmmeter to zero before resistance measurements or continuity tests are made.

## LEARNING OUTCOME 1

### Select measuring instrument

## PERFORMANCE STANDARDS

- Object or component to be measured is identified.
- Correct specifications are obtained from relevant source.
- Appropriate measuring instrument is selected in line with job requirement.



## What Do You Already Know?

Let us determine how much you already know about selecting measuring instrument. Take this test.

Pretest LO 1

**Directions: Choose the best answer. Write the letter only.**

1. Which component resists the flow of current in an electrical circuit?  
A) Capacitor      B) Inductor      C) Resistor      D) Transistor
2. What kind of component is a resistor?  
A) Combined      B) Discrete      C) Integrated      D) Hybrid
3. What color in the color coding scheme has an equivalent of 5 in the 2nd band?  
A) Brown      B) Green      C) Red      D) Yellow
4. What is the color of the tolerance representing  $\pm 10\%$ ?  
A) Gold      B) Black      C) Orange      D) Silver
5. What is the value of a resistor with the following colors :  
Green - Black- Silver- Gold?  
A) 500 Ohms  $\pm 5\%$       C) 5.0 Ohms  $\pm 5\%$   
B) 50 Ohms  $\pm 5\%$       D) 0.5 Ohm  $\pm 5\%$



# What Do You Need To Know?

Read Information Sheet 1.1 very well then find out how much you can remember and how much you have learned by doing Self-Check.

Information Sheet 1.1

Electronics is a branch of technology that deals with many applications. Audio electronics, video electronics, digital, medical up to weapons and banking are covered by the influence of electronics. There are quite a number of components used in the application of electronics. To name a few of these electronic components are resistors, capacitors, inductors and semi-conductors.

## TYPES OF RESISTORS

Wire-wound



Film



Carbon-composition resistors

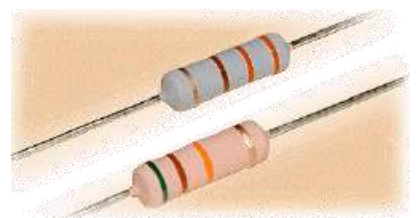

Precision



Resistors in band

Metal-film



Variable Resistor (Slide type)



Variable Resistor (Rotary type)



The most commonly used electronic components in the field are known as resistors. Resistor is a discrete component that offers opposition to the flow of current. Resistors have different types in accordance with the material used like carbon-composition and the wire-wound resistor. According to construction, we have the fixed resistor and the variable resistor.

Resistors are very common and are the cheapest electronic components in the market for so many years. Their features are so interesting and are very colorful. That's why resistors are very popular among students studying electronics.

One distinct feature of this resistance - giving component is the way its value is determined. It uses a set of colors which follows a code for its assumed resistance expressed in OHMS.

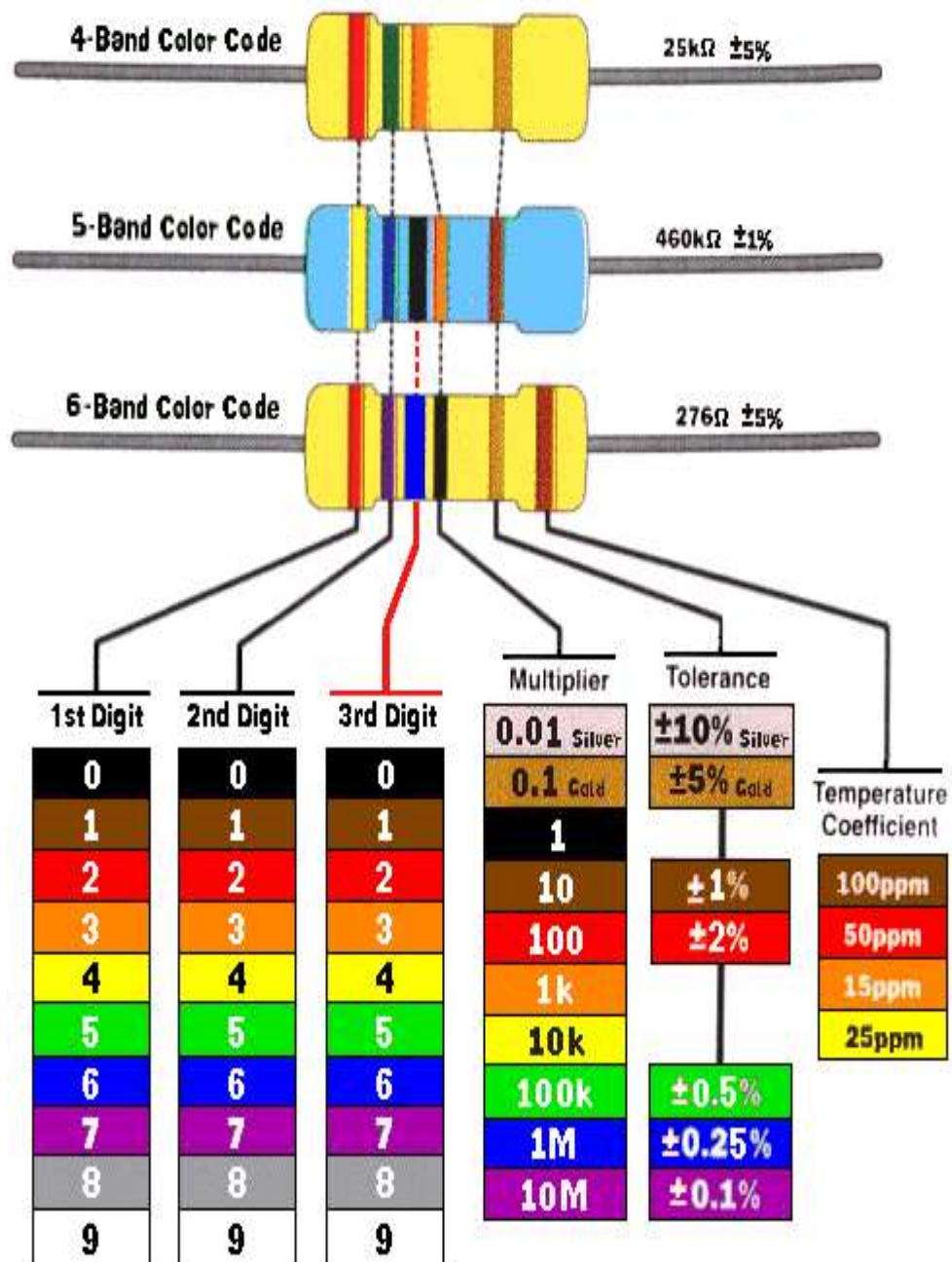

## RESISTOR COLOR CODING CHART

COLORS	1 <sup>ST</sup> BAND	2 <sup>ND</sup> BAND	MULTIPLIER	TOLERANCE
BLACK	—	0	1	
BROWN	1	1	10	
RED	2	2	10 <sup>2</sup>	
ORANGE	3	3	10 <sup>3</sup>	
YELLOW	4	4	10 <sup>4</sup>	
GREEN	5	5	10 <sup>5</sup>	
BLUE	6	6	10 <sup>6</sup>	
VIOLET	7	7	—	
GRAY	8	8	—	
WHITE	9	9	—	
GOLD	—	—	0.1	± 5%
SILVER	—	—	0.01	± 10 %
NO COLOR	—	—	—	± 20%

EXAMPLE:

1. BROWN - BLACK - BROWN - GOLD

$$\begin{array}{cccc}
 / & / & / & / \\
 1 & 0 & \times & 10 & \pm 5\% \\
 10 \times 10 = & 100 \text{ OHMS} & \pm 5\%
 \end{array}$$

2. Yellow – Violet – Yellow - Silver

$$\begin{array}{cccc}
 / & / & / & / \\
 4 & 7 & 10000 & \pm 10\%
 \end{array}$$

$$47 \times 10000 = 470,000 \text{ Ohms} \pm 10\%$$

or 470K ohms ±10%



## How Much Have You Learned?

### Self-Check 1.1

Directions: Multiple Choice. Choose the best answer. Write the letter only.

1. What is the value of a resistor with the following colors:  
Green - Black- orange - Gold?  
A) 500 Ohms  $\pm$  5%                      C) 50K ohms  $\pm$  5%  
B) 5K Ohms  $\pm$  5%                      D) 500 K Ohms  $\pm$  5%
2. What is the color of the tolerance representing  $\pm$  5%?  
A) Gold                      B) Black                      C) Orange                      D) Silver
3. 5 in the second band of the resistor color coding means  
A) Brown                      B) Green                      C) RedD) Yellow
4. Which component is a discrete type?  
A) Power IC                      B) Regulator IC                      C) Resistor                      D) Digital IC
5. Resistor is a component that resists the flow of \_\_\_\_\_.  
A) Current                      B) Capacitance                      C) Power                      D) Voltage

**Refer to the Answer Key. What is your score?**



## How Do You Apply What You Have Learned?

**Show that you learned something by doing this activity**

### Operation Sheet 1.1

#### Materials:

- 10 pieces     - Carbon resistors, 1 watt, assorted values
- 1 pc            - Resistor Tabulation form

#### Procedure:

1. Arrange the resistors on a piece of styrofoam in random manner.
2. Identify the colors of the resistors one by one and record them in the resistor tabulation form.
3. Compute for the resistance value of each resistor by following the color coding scheme.
4. Write the value of the resistance in the tabulation form.
5. Arrange the resistors in such a way that the value is in ascending manner.



**Resistor Tabulation Form**

1 <sup>st</sup> band Color/value	2 <sup>nd</sup> band Color/value	3 <sup>rd</sup> band multiplier	Coded value	Tolerance	Over-all Value
1					
2					
3					
4					
5					
6					
7					
8					
9					
10					



## How Well Did You Perform?

**Find out by accomplishing the Scoring Rubric honestly and sincerely.  
Remember it is your learning at stake!**

**Find out by accomplishing the Scoring Rubrics honestly and sincerely. Remember it is your learning at stake**

- With perfect score of 10 ..... 5
- With 1 mistake ..... 4
- With 2 – 3 mistakes.....3
- With 4 – 5 mistakes ..... 2
- With more than 5 mistakes ..... 1

## Performance Test.

Learner's Name		Date		
Competency:		Test Attempt 1st      2nd      3rd		
<p><b>Directions:</b></p> <p>CALL TEACHER and ask him / her to assess your performance in the following critical task using the performance criteria below</p> <p>You will be rated based on the overall evaluation on the right side.</p>	<b>OVERALL EVALUATION</b>			
	<b>Level Achieved</b>	<b>PERFORMANCE LEVELS</b>		
		4 - Can perform this skill without supervision and with initiative and adaptability to problem situations.		
		3 - Can perform this skill satisfactorily without assistance or supervision.		
		2 - Can perform this skill satisfactorily but requires some assistance and/or supervision.		
		1 - Can perform parts of this skill satisfactorily, but requires considerable assistance and/or supervision.		
Teacher will initial level achieved.				
<b>PERFORMANCE STANDARDS</b>				
For acceptable achievement, all items should receive a "Yes" or "N/A" response.		<b>Yes</b>	<b>No</b>	<b>N/A</b>
1. Can recite the colors of the color coding chart in order without looking at the chart.				
2. Can identify the first color of the carbon resistor.				
3. Can interpret equivalent numerical value of each color in the chart				
4. Can calculate the color coded value of the resistor.				
5. Can give the over-all value of the resistor after calculation.				

## LEARNING OUTCOME 2

### Carry out measurement and calculation

## PERFORMANCE STANDARDS

- Appropriate measuring instruments are selected to achieve required outcome.
- Accurate measurements are obtained for job specifications.
- Calculations needed to complete work task are performed using four fundamental operations.
- Instruments are read to the limit accuracy of the tool.



## What Do You Already Know?

Let us determine how much you already know about carrying out measurement and calculation. Take this test.

### Pretest LO 2

Directions: **Multiple Choice.** Choose the best option. Write the letter only.

1. What is the item in the color coding scheme that allows the color-coded value to deviate to a certain extent?  
A) Multiplier  
B) Body color  
C) Limitation  
D) Tolerance
2. What is the decimal equivalent of 10%?  
A) .01  
B) 0.1  
C) 1.0  
D) 10
3. What is 10% of 220?  
A) 210  
B) 2.2  
C) 22  
D) 11
4. What is the maximum deviation of a 220ohms + 10% tolerance?  
A) 230ohms  
B) 242 ohms  
C) 224 ohms  
D) 236 ohms

5. What is the minimum deviation of – 10% tolerance of the same resistor cited in no. 4?
- A) 90 ohms                      C) 190 ohms  
B) 198 ohms                     D) 210 ohms



## What Do You Need To Know?

**Read Information Sheet 2.1 very well then find out how much you can remember and how much you learned by doing Self-Check.**

### Information Sheet 2.1

Resistor color coded value is not absolute. The real resistance of the resistor is sometimes lower or higher than its color coded value but not to exceed its tolerance level.

Tolerance is the limit on how far the real value of the resistor can deviate from its color coded value. It can be more or less but subjected to a tolerable limit.

In the color coding chart there is a column for tolerance. Color *gold* is + or – 5%, *silver* is + or – 10 %, and the *no color* means + or – 20%.

### **Procedure in interpreting the tolerance of resistor**

1. Identify the tolerance color of the resistor being analyzed. Assuming the color is gold which has a value of + or – 5%.
2. Convert the percentage into its decimal equivalent. 5% is equivalent to .05
3. Compute for the percentage of the color coded value. Assuming that the color coded value is 100 ohms ± 5%.  
So  $100 \times .05 = 5$
4. For the + side, add 5 to the color coded value of 100.  
 $100 + 5 = 105$  ohms

That is the maximum deviation for that resistor. Beyond that, the resistor will not be fitted for the circuit which requires such tolerance.

5. For the – side, deduct 5 from the color coded value of 100.  
 $100 - 5 = 95$  ohms

That will be the minimum deviation for that particular resistor. Far beyond that the resistor will be considered to be defective.

6. Finally the value of the resistor with colors brown- black- brown – gold is 100 ohms with a deviation of +5 or -5. (95 ohms -105 ohms)



## How Much Have You Learned?

### Self-Check 2.1

**Directions: Choose the best option. Write the letter only.**

1. What is the minimum resistance of a 100 ohm resistor with 10% tolerance?  
A) 90 ohms  
B) 190 ohms  
C) 190 ohms  
D) 210 ohms
2. What is the maximum value of a 220 ohm resistor with a + 10% tolerance?  
A) 230 ohms  
B) 242 ohms  
C) 224 ohms  
D) 236 ohms
3. What is 10% of 220?  
A) 210  
B) 2.2  
C) 22  
D) 11
4. What is the decimal equivalent of 5%?  
A) .01  
B) .05  
C) 1.0  
D) 10
5. The band in the color coding scheme that permits the value to deviate to a certain extent?  
A) Multiplier  
B) Body color  
C) Limitation  
D) Tolerance

**Refer to the Answer Key. What is your score?**



## How Do You Apply What You Have Learned?

Show that you learned something by doing this activity

### Operation Sheet 2.1

Objective: To compute for the tolerance ceiling of carbon resistors.

Materials:

- 10pcs. Carbon resistors
- Paper and pencil

Procedure:

1. Arrange resistors as done in the first operation.
2. Identify the tolerance color and record them in the resistor tabulation sheet.
3. Compute for the maximum value of the + tolerance.
4. Compute for the maximum value of the – tolerance.

### RESISTOR TABULATION SHEET

Colors	Coded value	Tolerance	Maximum value	Minimum value



## How Well Did You Perform?

**Find out by accomplishing the Scoring Rubric honestly and sincerely.  
Remember it is your learning at stake!**

- With perfect score of 10 .....5
- With 1 mistake .....4
- With 2 – 3 mistakes..... 3
- With 4 – 5 mistakes .....2
- With more than 5 mistakes .....1

### Information Sheet 2.2

Resistor color coding gives us the color coded value of a given resistor as well as the maximum and minimum value as dictated by the tolerance but the actual resistance is still unknown to us. The actual value of the resistor and the recorded data will confirm the status of the resistor, whether good or defective.

#### **OHMMETER**

Ohmmeter is a measuring instrument used to determine the resistance of a component or equipment. This instrument is a great help in knowing the actual resistance of the resistors we use in the two operation sheets.

The commonly used ohmmeter in electro-electrical laboratories nowadays is embedded in a multi-function testing instrument called the (Volt-Ohm-Milliammeter ) VOM. For this discussion the VOM will be used but confined only to the ohmmeter section.





Volt-Ohm-Milliammeter (VOM)

#### Parts of an Ohmmeter

1. Pointer. It is the most important part of the ohmmeter. It indicates the value of electrical quantity that has been measured.



2. Ohmmeter Scale- Nonlinear scale where reading of the resistance is based. It is usually found in the uppermost part of the VOM.



Range Multiplier- The portion of the ohmmeter where the actual reading is being multiplied.

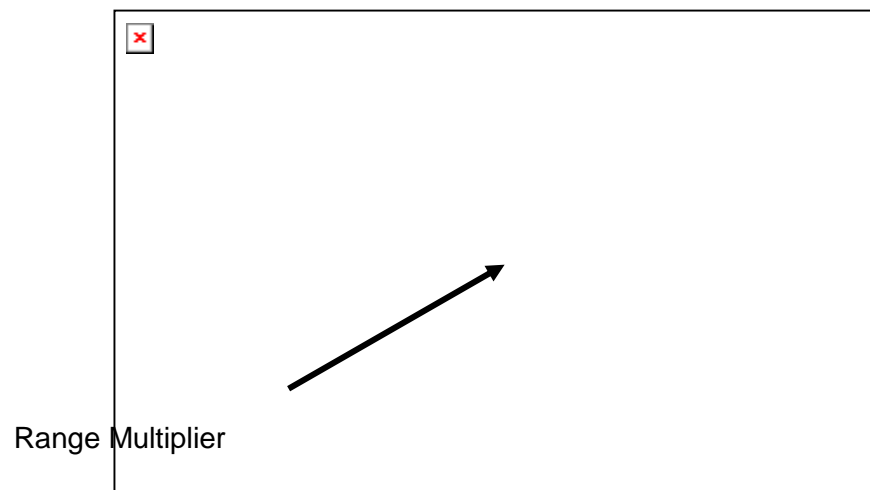

Zero Ohm Adjustment – It is the portion of the ohmmeter where it is adjusted when the pointer of the ohmmeter fails to point to zero.

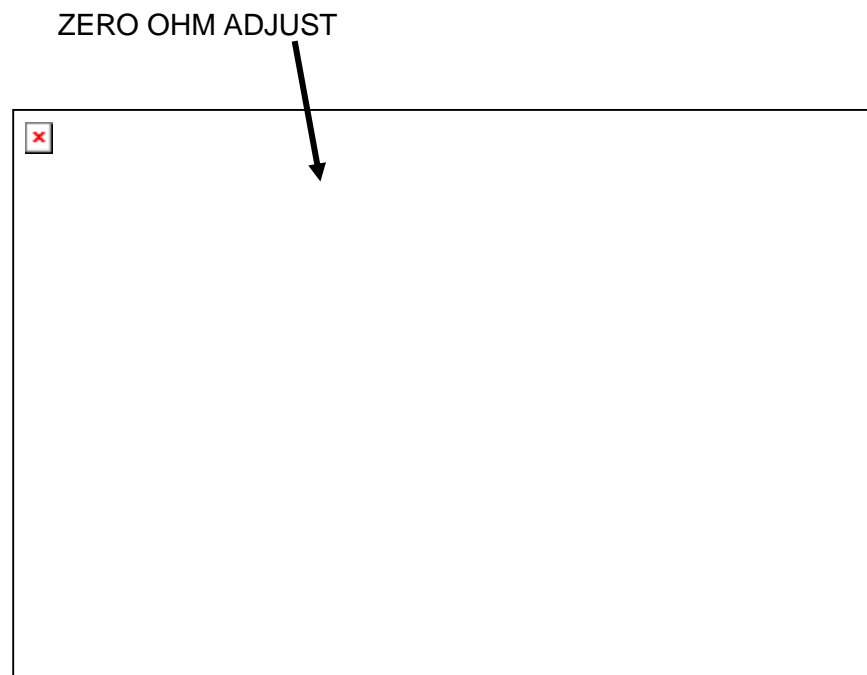

Test Probe- It serves as the input portion of the ohmmeter. It has the Red test probe as negative while the black one is positive.

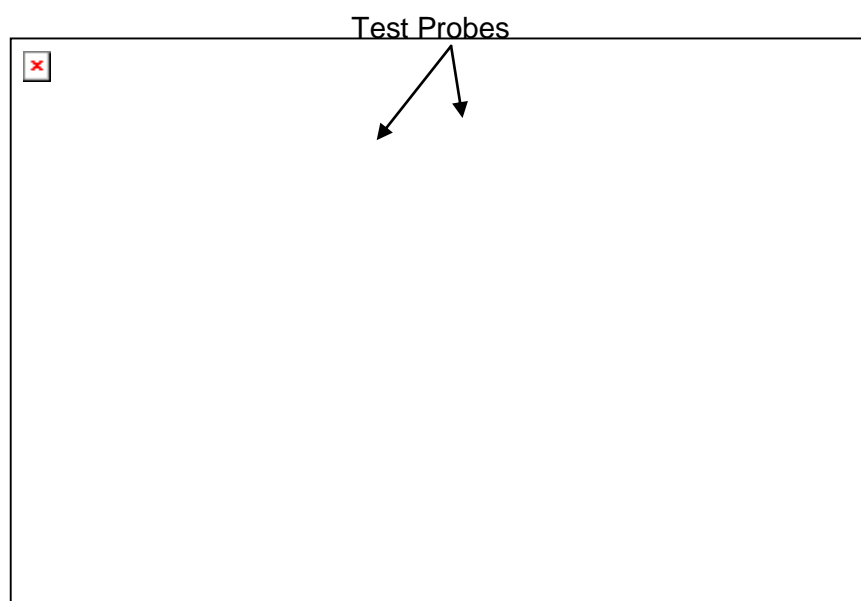

## PROCEDURE ON HOW TO INTERPRET RESISTANCE READING IN AN OHMMETER

1. Know the value of individual calibration in the ohmmeter scale.

An ohmmeter scale is nonlinear which means the value of one line or calibration may not be true to other lines. It is therefore proper to assign values to every line for proper and accurate interpretation



As shown in the illustration, the scale can be divided into eight areas where individual treatment has to be made. Several mathematical computations will be involved to show the manner how values of individual lines are resolved.

The areas involved are 0- 2, 2-10, 10 -20, 20-50, 50 – 100, 100- 200, 200 – 300, 300 – 500.

Value of 1 calibration = line distance / total calibrations involved

### For 0- 2:

$$\begin{aligned}\text{Line distance} &= 2 \\ \text{Total no. of cal} &= 10 \\ \text{Value of 1 line} &= 2/10 \\ &= \mathbf{0.2}\end{aligned}$$

### For 2-10:

$$\begin{aligned}\text{Line Distance} &= 8 \\ \text{Total no. of cal} &= 16 \\ \text{Value of 1line} &= 8/16 \\ &= \mathbf{0.5}\end{aligned}$$

### For 10-20:

$$\begin{aligned}\text{Line Distance} &= 10 \\ \text{Total no. of cal} &= 10 \\ \text{Value of 1line} &= 10 /10 \\ &= \mathbf{1}\end{aligned}$$

### For 20 -50:

$$\begin{aligned}\text{Line Distance} &= 30 \\ \text{Total no. of cal} &= 15 \\ \text{Value of 1 line} &= 30/15 \\ &= \mathbf{2.0}\end{aligned}$$

**For 50-100:**

Line Distance = 50  
Total no. of cal = 10  
Value of 1 line =  $50/10$   
= **5.0**

**For 100 – 200:**

Line Distance = 100  
Total no. of cal = 5  
Value of 1 line =  $100/5$   
= **20**

**For 200-300:**

Line Distance= 100  
Total no. of lines = 2  
Value of 1 line =  $100/2$   
= **50**

**For 300–500:**

Line Distance = 200  
Total no. of cal= 2  
Value of 1 line =  $200/2$   
= **100**

2. Identify the appropriate range multiplier to be used Range multiplier is from R X 1, R X 10, R X 100, R X 1K, and R X 10K.
3. Connect the metallic part of the test probes and take note if the pointer points at zero. If not, adjust the zero ohm adjustment to zero.
4. Make the necessary resistance measurements.



## How Much Have You Learned?

### Self-Check 2.2

**Directions:** Choose the best answer. Write the letter only.

1. What is the instrument that is used to measure resistance?  
A) Ammeter                      C) Voltmeter  
B) Ohmmeter                      D) Wattmeter
2. From what part of the ohmmeter do you derive resistance reading?  
A) Range Multiplier              C) Test Probes  
B) Reading Scale                      D) Pointer
3. What is the lowest range multiplier in an ohmmeter?  
A) RX 1                              C) R X 100  
B) R X 10                              D) R X 1K
4. The reading scale of the ohmmeter is of what type?  
A) Horizontal                      C) Nonlinear  
B) Linear                              D) Vertical
5. In what instrument can you find the ohmmeter?  
A) Ammeter                      C) DMM  
B) Tube tester                      D) VOM

**Refer to the Answer Key. What is your score?**



## How Do You Apply What You Have Learned?

Show that you learned something by doing this activity

Operation Sheet 2.2

Tools and Materials:

1 unit	Ohmmeter
1 pair	Long nose pliers
10 pieces	assorted value carbon resistors

**Directions:** On a piece of paper (Resistor Tabulation Sheet), record the resistances of the 10 resistors following the procedure in resistance measurements. Compare the reading (measured value) with the color-coded value.

### RESISTOR TABULATION SHEET

Colors	Color - coded Value	Tolerance	Maximum Value	Minimum Value	Measured Value	Remarks



## How Well Did You Perform?

**Find out by accomplishing the Scoring Rubric honestly and sincerely.  
Remember it is your learning at stake!**

- With perfect score of 10 ..... 5
- With 1 mistake ..... 4
- With 2 – 3 mistakes.....3
- With 4 – 5 mistakes .....2
- With more than 5 mistakes ..... 1



## LEARNING OUTCOME 3

### Maintain measuring instruments

## PERFORMANCE STANDARDS

- Measuring instruments are handled properly to avoid damage.
- Measuring instruments are cleaned before and after using
- Proper storage of instruments is undertaken according to the manufacturer's specifications and standard operating procedure.



## Materials



## What Do You Already Know?

Let us determine how much you already know about maintaining measuring instrument. Take this test.

### Pretest LO 3

Directions: Choose the best answer and write the letter only.

1. Which instrument serves as 3 measuring instruments in one?  
A) Audio Generator  
B) Oscilloscope  
C) Signal Generator  
D) VOM
2. Which device produces simple wave forms?  
A) Audio Amplifier  
B) VOM  
C) Signal tracer  
D) Signal Generator
3. Where is the function switch rested if an off position is not available In the VOM?  
A) 10VDC  
B) 50 VAC  
C) 100 VAC  
D) 250 VAC

4. Place instruments in a cool dry place and away from any \_\_\_\_\_ devices.
- |                      |                     |
|----------------------|---------------------|
| A) Audio amplifiers  | C) Magnetic devices |
| B) Other instruments | D) Digital sources  |
5. What measuring instrument should be given regular check up by connecting it to power line?
- |                     |                 |
|---------------------|-----------------|
| A) Capacitor Tester | C) Oscilloscope |
| B) DMM              | D) VOM          |

]



## What Do You Need To Know?

**Read Information Sheet 3.1 very well then find out how much you can remember and how much you learned by doing Self-Check.**

Information Sheet 3.1

Measuring instruments in electronics are confined only to analog testers and sometimes digital millimeter. Either way the maintenance of these instruments is a priority in all electronics laboratory rooms.

### **Electronic Measuring Instruments**

Aside from hand tools, measuring instruments are also needed for more accurate and quality output. In this connection, three of the most used instruments are presented here for you to be familiar with their uses and the proper way of maintaining them.

Volt-Ohm-Milliammeter. It is an equipment that combines three functions: as a voltmeter that measures both ac and dc voltages; an ohmmeter that measures resistance; and as a milliammeter that measures small amount of dc current. As safety precautions in the maintenance of this instrument, the following should be observed:



#### VOLT – OHM - Millimeter

- Always rest the function switch at 250V AC, if an OFF position is not available in the instrument.
- For current and voltage measurements, always set the function switch in the correct setting which is a little higher than the expected current or voltage present in the circuit.
- Place the instrument in a cool dry place, away from any magnetic devices, and free from vibrations.

Oscilloscope. An oscilloscope (commonly abbreviated CRO, for cathode-ray oscilloscope, or scope) is a piece of electronic test equipment that allows signal voltages to be viewed, usually as a two-dimensional graph of one or more electrical potential differences (vertical axis) plotted as a function of time or of some other voltage (horizontal axis).

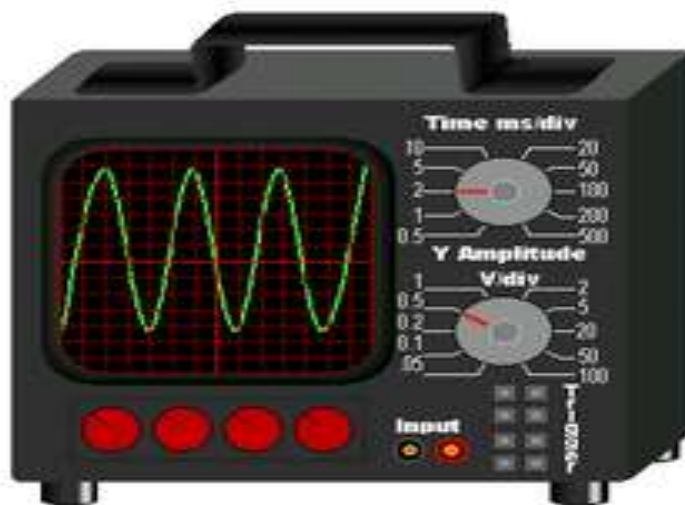

OSCILLOSCOPE

Signal generator. A signal generator is a device which produces simple waveforms.



SIGNAL GENERATOR

Such devices contain an electronic oscillator, a circuit that is capable of creating a repetitive waveform. These are typically used in simple electronics repair and design where they are used to stimulate a circuit under test.

Oscilloscope and signal generator should be given regular checkup for at least once a week by connecting them to the power line. This will help prevent their components from having moisture that might cause trouble in their circuits.

In any activity involving skills, it is a standard procedure that you must always use the right tool or equipment properly needed for particular task. However, in spite of this reminder or caution, some students abuse the use of tools.



## How Much Have You Learned?

### Self-Check 3.1

Directions: Choose the best answer and write the letter only.

1. What is the instrument that serves as 3 measuring instruments in one?  
A) Audio Generator  
B) Oscilloscope  
C) Signal Generator  
D) VOM
2. What is a device which produces simple wave forms?  
A) Audio Amplifier  
B) VOM  
C) Signal tracer  
D) Signal Generator
3. Where is the function switch rested if an off position is not available in the VOM?  
A) 10VDC  
B) 50 VAC  
C) 100 VAC  
D) 250 VAC
4. Place instruments in a cool dry place and away from any \_\_\_\_\_ devices.  
A) Other instruments  
B) Audio amplifiers  
C) Magnetic devices  
D) Digital sources
5. What measuring instrument should be given regular checkup by connecting them to power line?  
A) Capacitor Tester  
B) DMM  
C) Oscilloscope  
D) VOM

**Refer to the Answer Key. What is your score?**



**Congratulations! You did a great job! Rest and relax a while then move on to the next lesson. Good luck!**

## REFERENCES

- Enriquez, Marcelo T., Electronics Technology IV; Souvenir Publications, Inc. 2003
- Grob, Bernard, Basic Electronics, 4<sup>th</sup> Edition; New York: McGraw-Hill Company, USA: 1982
- Tan, Michael Q.; Gantalao, Fred T.; Lasala, Rommel M. Simple Electronics; Andes Mountain Printers; 2004

## LESSON 3

### Prepare and Interpret Technical Drawings

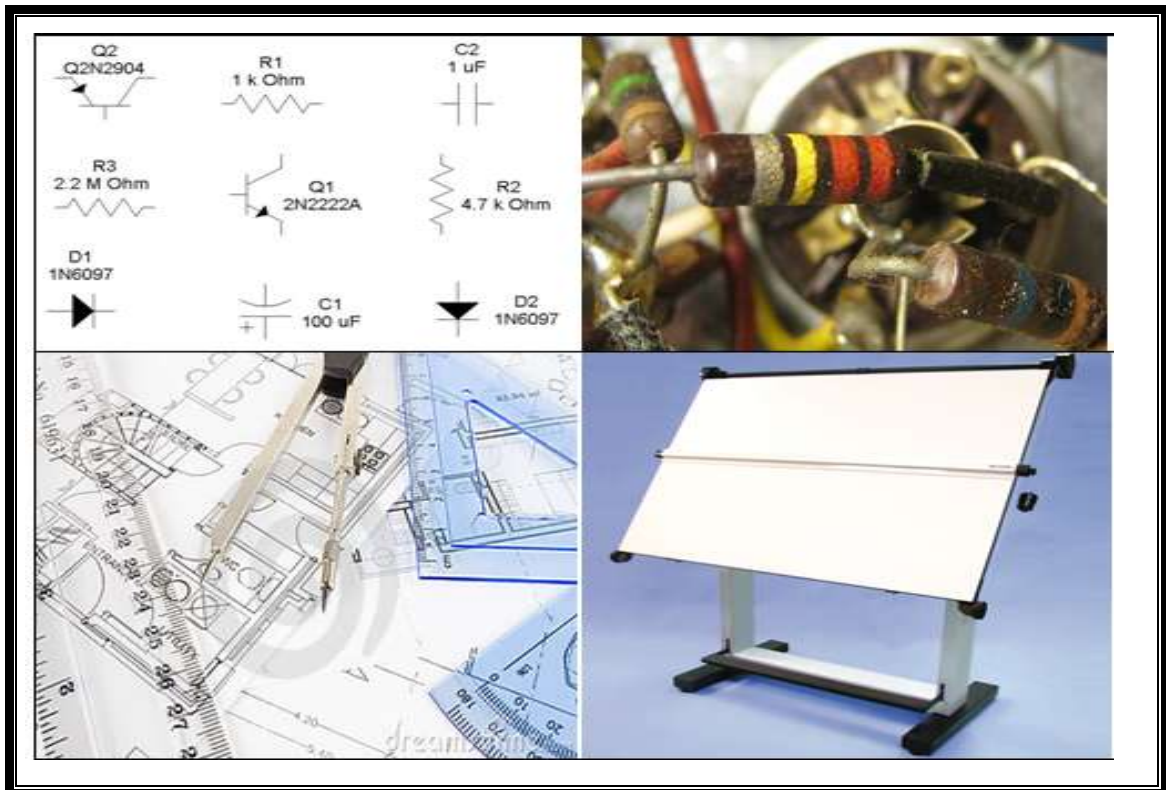

#### LEARNING OUTCOMES:

At the end of this Lesson, you are expected to do the following:

- LO 1. identify different kinds of technical drawings;
- LO 2. interpret technical drawing; and
- LO 3. prepare/ make changes on electrical/ electronic schematics and diagrams.



## Definition of Terms

**AC voltage** - a voltage in which the polarity alternates

**Anode** - the positive electrode or terminal of a device. The “P” material of a diode

**Bridge Rectifier** - a circuit using four diodes to provide full-wave rectification. It converts AC voltage to a pulsating DC voltage

**Calibration** – used to adjust the correct value of a reading with comparison to a standard value

**Color Code** - set of colors used to indicate value of a component

**DC Power Supply** – converts alternating current to direct current power source

**Diode** - a two terminal device that conducts in only one direction

**Full Wave Rectifier** - the rectifier that makes use of the full ac wave in both positive and negative half cycles

**Fuse** - a device in the current path that melts or breaks when current protective exceeds a predetermined maximum value

**Half Wave Rectifier** - a diode rectifier that converts AC to pulsating DC by eliminating either the negative or positive alternation of each input AC cycle

**Leakage** - small undesirable flow of current through an insulator or dielectric

**Light Emitting Diode** - a semiconductor diode that converts electric energy into electromagnetic radiation at a visible and near infrared frequencies when its PN junction is forward bias

**Output** - terminal at which a component, circuit or piece of equipment delivers current, voltage or power

**Power Supply** - electrical equipment used to deliver either AC or DC voltage

**Primary** - first winding of a transformer winding that is connected to the source as opposed to secondary which is a winding connected to a load

**Printed Circuit Board (PCB)** - insulating board containing conductive tracks for circuit connections

**Rectification** - process that converts alternating current to direct current

**Rectifier** - diode circuit that converts AC to pulsating DC



**Regulated Power Supply** - power supply that maintains a constant output voltage under changing load condition

**Rotary Switch** - electromechanical device that has a rotating shaft connected to one terminal capable of making, breaking a connection to one or more other terminals

**Schematic Diagram** - illustration of an electrical or electronic circuit with the components represented by their symbol

**Secondary** - output winding of a transformer winding that is connected to a load

**Short Circuit** - Low resistance connection between two points in a circuit typically causing excessive current and overheating

**Solder** - metallic alloy used to join two metal surfaces

**Soldering Iron** - tool with an internal heating element used to heat surfaces being soldered where the solder becomes molten

**Substrate** - mechanical insulating support upon which a device is fabricated

**Switch** - electrical device having two states, ON (closed) or OFF (open)

**Test** - sequence of operations intended to verify the correct operation or malfunctioning of a piece of equipment or system

**Transformer** - inductor with two or more windings

**Troubleshooting** - systematic approach to locate the cause of a fault in an electronic circuit or system

**Volt-Ohm-Milliammeter** - known as a multimeter. A test equipment used to check AC, DC voltages, current in a circuit and resistance of any components out of the circuit

## LEARNING OUTCOME 1

### Identifying different kinds of technical drawings

## PERFORMANCE STANDARDS

- Correct technical drawing is selected according to job requirements.
- Technical drawings are segregated in accordance with the types and kinds of drawings.



## What Do You Already Know?

Let us determine how much you already know about identifying different kinds of technical drawings. Take this test.

Pretest LO 1

**DIRECTIONS:** Write the letter of the best answer on the space provided for before each number. Use another sheet of paper for your answer.

- \_\_\_\_\_ 1. A drawing instrument consisting of two parts namely the stock and the blade, joined together at right angles to each other by means of screws.
- |               |               |
|---------------|---------------|
| A. L-square   | C. T-square   |
| B. Try square | D. Protractor |
- \_\_\_\_\_ 2. It is a combination of T-squares, scales, set squares, and protractors attached to a drawing board.
- |                        |                 |
|------------------------|-----------------|
| A. Drafter             | C. Drawing set  |
| B. Electronic template | D. French curve |
- \_\_\_\_\_ 3. This device includes symbols for electronic and electrical design that can be traced using a drawing pencil.
- |                      |                        |
|----------------------|------------------------|
| A. Triangular rule   | C. French curve        |
| B. Electronic manual | D. Electronic template |

\_\_\_\_\_ 4. It is a smooth board usually rectangular in shape provided with perfectly straight edge which is used as working edge on which the T-square is moved while making drawings.

- A. Drawing board
- B. Breadboard
- C. T-square
- D. Set of squares

\_\_\_\_\_ 5. A drawing instrument with two legs hinged at one end and is used for drawing circles and arcs of circles.

- A. Drafting pen
- B. Compass
- C. Technical pen
- D. Protractor

Criteria for Evaluating Results of Pre-Test

100%-skip the Learning Outcome and proceed to the next Learning Outcome

99%-below – Go through the Learning Outcome



## What Do You Need To Know?

**Read Information Sheet 1.1 very well then find out how much you can remember and how much you learned by doing Self-check 1.1.**

Information Sheet 1.1

When you purchase a brand new appliance or equipment, it is very important that a diagram is included with the product to insure that there will be a reference material in case the appliance or equipment becomes defective. Shown in Fig. 1-1a is the schematic diagram of a 1-watt stereo audio amplifier, while Fig. 1-1b is its pictorial diagram.

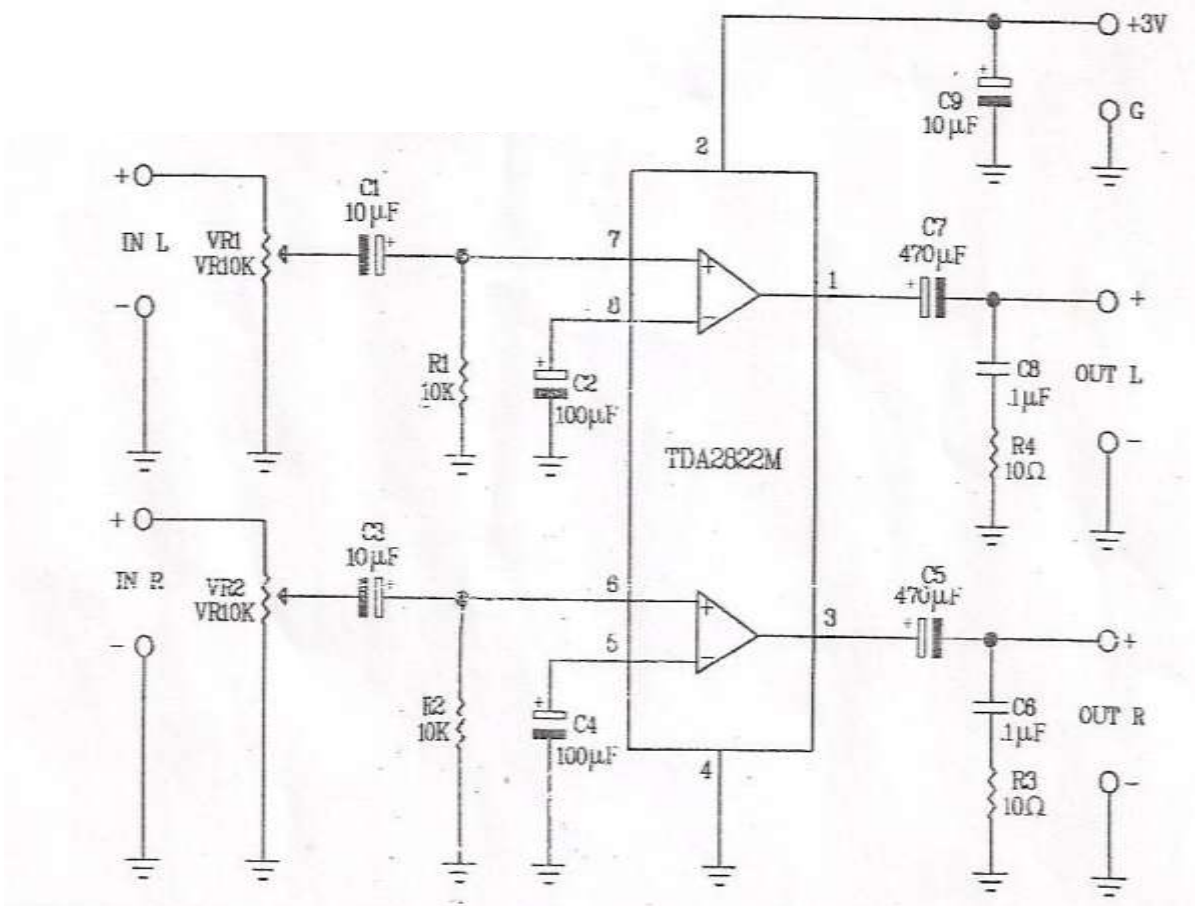

Fig. 1-1a. Schematic diagram of the 1-watt stereo amplifier.

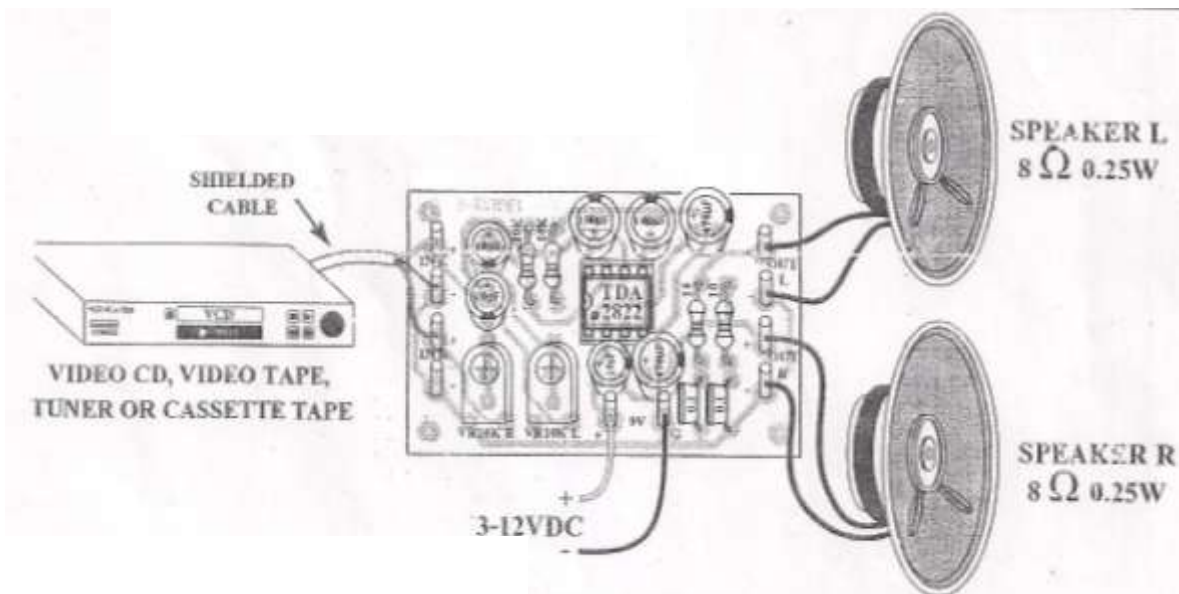

Fig. 1-1b. Pictorial diagram of the 1-watt stereo amplifier.

To produce a quality and marketable electronic diagram, you have to follow the Electronic Drafting Standards which is the process of illustrating various kinds of circuits and wiring systems.

The most common graphical languages used in the illustration of components in circuits and wiring systems are **block**, **schematic**, **wiring**, and **pictorial diagrams**.

Most symbols that you will encounter in laying out electronic diagrams are accepted as standard, but in some cases some manufacturers modify symbols and practices to suit a particular industrial policy while others use their own symbols to represent unique or special component and devices.

**D**o you know that electronic symbols and their use in conjunction with recommended drafting practices have been developed through the years, and have been standardized by a number of different organizations? Among these are the American National Standards Institute (ANSI), the Electronics Industries Association (IEA), the Institute of Electrical and Electronics Engineers (IEEE), and the International Electrotechnical Commission (IEC).

## Schematic Symbols of Electronic Components

Some of the electronic symbols that were mentioned earlier are shown in Fig. 1-2. You can use several electronic templates shown in Fig. 1-3 to help you in drawing these symbols.

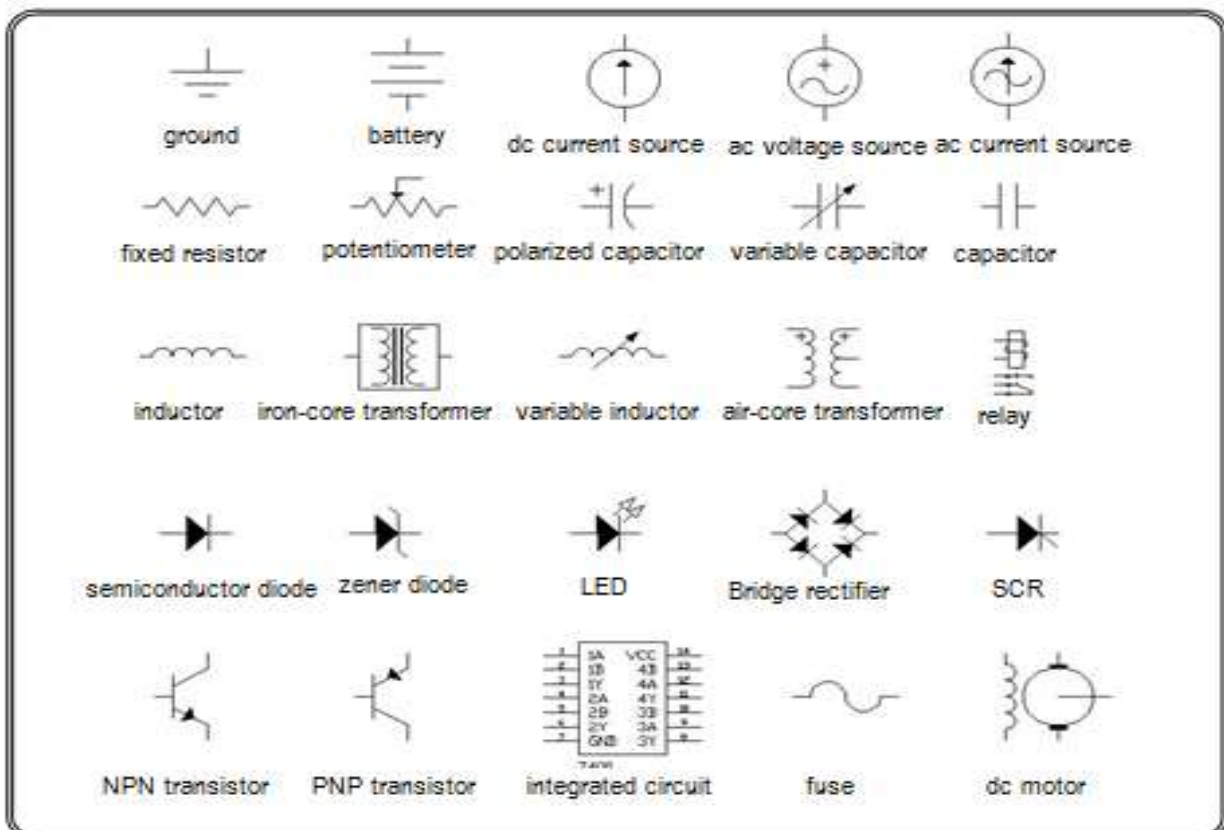

Fig. 1-2. Schematic Symbols of Electronic Components.

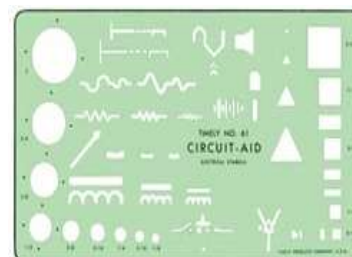
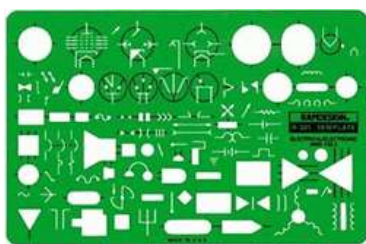

Fig. 1-3. Electronic templates

## Drawing instruments and their uses

Drawing instruments are used in preparing accurate drawings. Quality drawing instruments can produce accurate and good and presentable drawings. Below is a list of some of the most common used drawing instruments and materials in electronic drafting.

1. Drawing board. A smooth board usually rectangular in shape provided with perfectly straight edge which is used as working edge on which the T-square is moved while making drawings.



2. T-square. A T-square consists of two parts namely the stock and the blade joined together at right angles to each other by means of screws. The stock is made to slide along the working edge and the blade moves on the drawing board. The working edge of a T-square is used to draw parallel lines, vertical lines or inclined lines at 30 or 60 degrees.

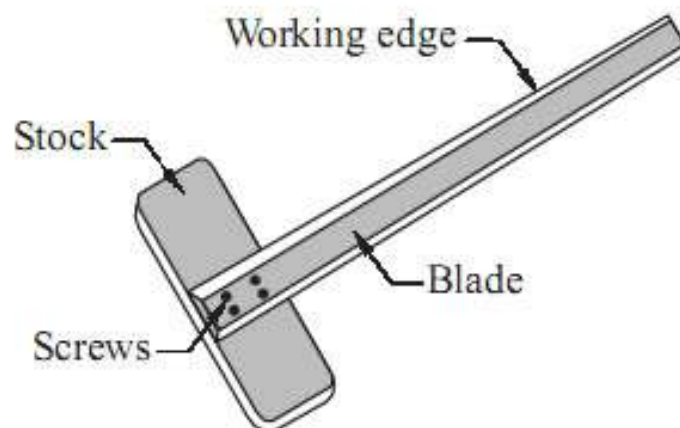

3

the uses and  
protractors are  
t top end of the

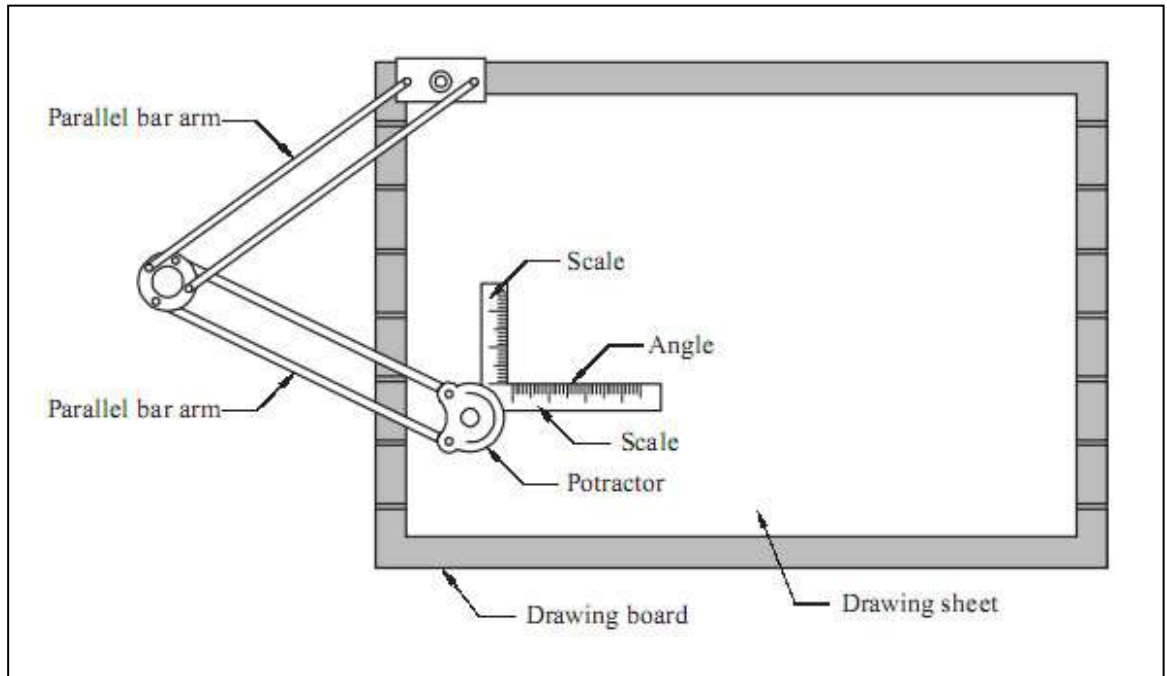

- Set squares. Set squares are generally made from plastic material. They are triangular in shape with one corner, a triangle. A pair of set squares ( $30^\circ - 60^\circ$ ) and  $45^\circ$ . They are used to draw lines at  $30^\circ$ ,  $60^\circ$  and  $45^\circ$  to the vertical or horizontal.

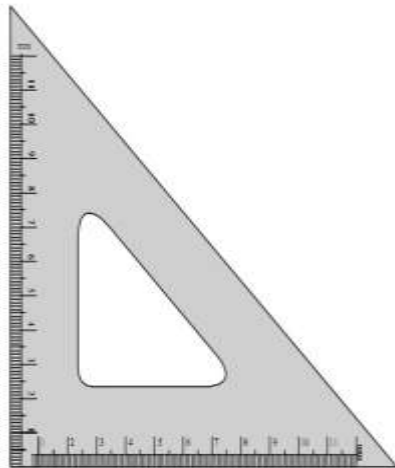

Fig. 1A.4.  $45^\circ$  Set Square

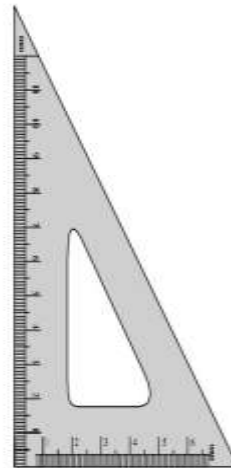
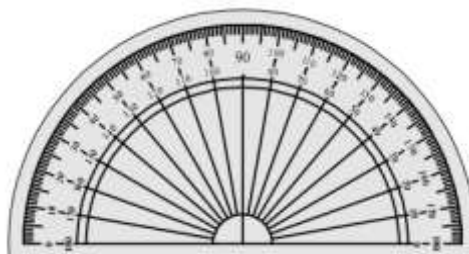

Fig. 1A.5.  $30^\circ - 60^\circ$  Set Square

- Protractor. Protractors are used to mark or measure angles between  $0$  and  $180^\circ$ . They are semicircular in shape and are made of plastic. Protractors with circular shape are capable of marking and measuring  $0$  to  $360^\circ$  are also available in the market.





6. Drawing pencils. The accuracy and appearance of a drawing depends on the quality of pencil used to make drawing. The grade of a pencil lead is marked on the pencil. HB denotes medium grade. Increase in hardness is shown by the value put in front of H such as 2H, 3H, etc. Softer pencils are marked as 2B, 3B, and 4B etc. A pencil marked 3B is softer than 2B and pencil marked 4B is softer than 3B and so on. Beginning of a drawing may be made with H or 2H. For lettering and dimensioning, H or HB pencils are used.



7. Compass. A compass is used for drawing circles and arcs of circles. The compass has two legs hinged at one end. One of the legs has pointed needle fitted at the lower end whereas the other end has provision for inserting pencil lead.



8. Drawing pins and clips. These are used to fix the drawing sheet on the drawing board.



CON

K to Pin (map pin, push pin, thumbtack) with a plastic handle as head



Paper Cricket push pin



Map pin with spherical head



Transparent push pins

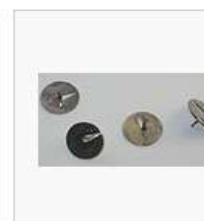

Stamped thumbtacks

9. Electronic templates include symbols for electronic and electrical design that can be traced using a drawing pencil.

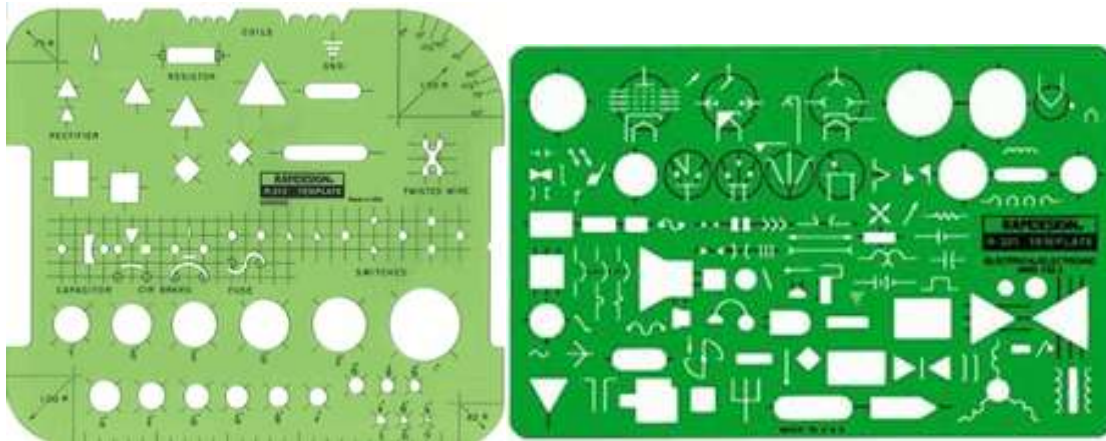



# How Much Have You Learned?

## Self-Check 1.1

**DIRECTIONS:** Draw at least five (5) drawing instruments, describe and give the function of each.

Drawing instrument	Description	Use

**Refer to the Answer Key. What is your score?**



## What Do You Already Know?

Let us determine how much you already know about the use farm tools and equipment. Take this test.

Pretest LO 2.1

**Directions:** Match the electronic and electrical symbols in Column A with the corresponding descriptions in column B. Write the letter of your answer on the space provided before each number.

### Column A

\_\_\_\_\_ 1. 

\_\_\_\_\_ 2. 

\_\_\_\_\_ 3. 

\_\_\_\_\_ 4. 

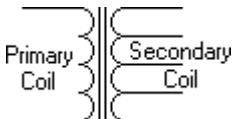
\_\_\_\_\_ 5. 

### Column B

A. Capacitor

B. Transistor

C. Transformer

D. Fuse

E. Resistor

F. Diode



## What Do You Need To Know?

Read Information Sheet 1.2 very well then find out how much you can remember and how much you learned by doing Self-check 1.2.

### Information Sheet 2.1

## Resistor

A resistor is a device with a known value of resistance. Its main function is to reduce voltage and to limit the flow of current in a circuit. This *resistance* is actually the opposition that a component or material offers to the flow of current.

Resistance may or may not be useful in circuit/s. When too much current passes through a *conductor*, (solid, liquid, gas through which electrons pass easily) the resistance of the conductor may cause it to become hot. This, in turn, can create a fire hazard or cause the conductor to burn out. In this case, it is not desirable. In other cases, when it is placed intentionally in the circuit, it performs its specific task.

### Symbol of Resistor

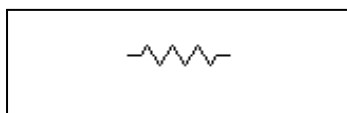

Fixed

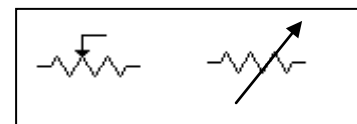

Variable

### Fixed Resistors

It is a single value resistance, which remains the same under the normal condition. The two common kinds of fixed resistors are *carbon resistor* and *film-type resistor*.

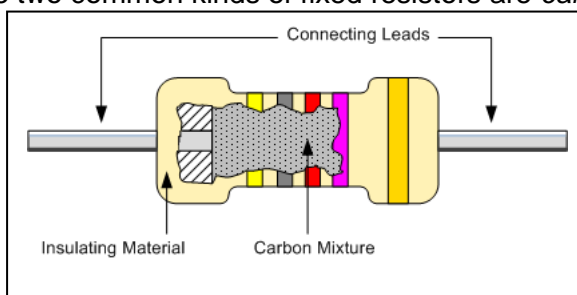

Carbon Resistor

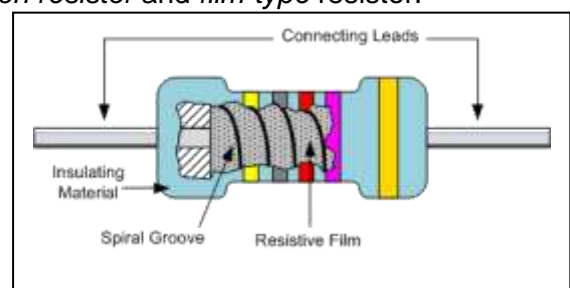

Film Resistor

## Variable Resistor

Variable resistors are used when it is necessary to change the amount of resistance in a circuit. There are two common variable resistors, the potentiometer and rheostat. Generally a *potentiometer* is generally has carbon resistive element while the *rheostat* is generally made of resistance wire.

Potentiometer



Rheostat



Both devices have a sliding arm that brings into contact with the resistance element. In most variable resistors the arm is attached to the shaft that can be adjusted

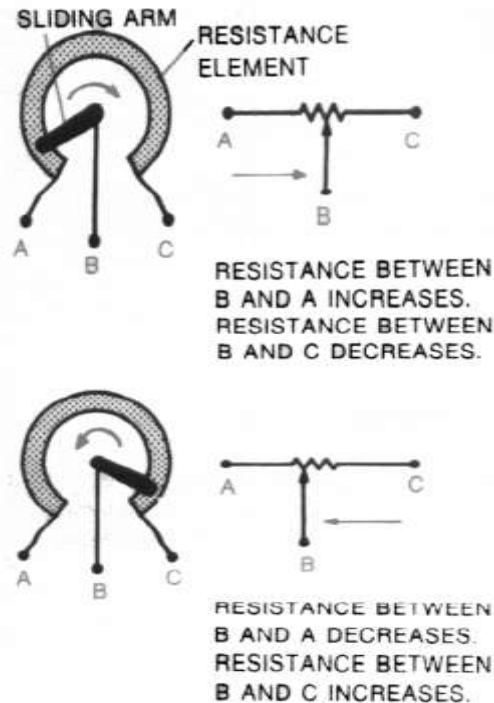

A potentiometer is commonly used as control device. It can be used to vary the value of voltage applied to a certain circuit such as in the amplifier, television, and different kinds of meter circuit.

### **Resistor Power Rating**

Power rating of resistors changes with their sizes, the bigger the resistor the greater the wattages and the smaller the resistor the lesser the wattage. Different sizes of resistors are shown below which are drawn to the exact proportion.

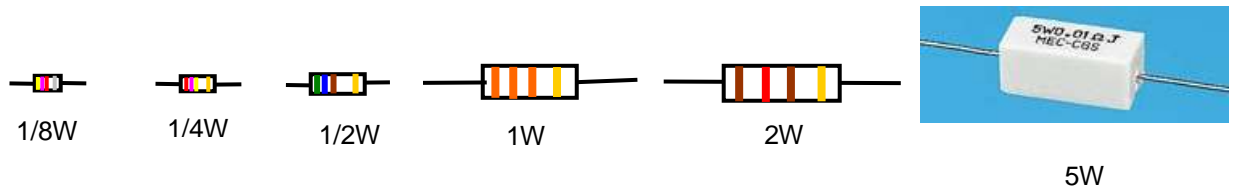

A *capacitor* is a device that consists essentially of two conducting surfaces separated by a dielectric material like air, paper, mica, ceramic, glass, or Mylar. It makes it possible to store electric energy. Electrons are detained within a capacitor. This, in effect, is *stored electricity*. It is known as electrical potential or an electrostatic field. Electrostatic field hold electrons. When the increase of electrons becomes great enough, the electrical potentials are now ready to be discharged.

The component is designed intentionally to have a definite amount of capacitance. This capacitance is a property that exists whenever insulating material permits the storage of electricity. It is measured in Farad (F) micro Farad ( $\mu\text{F}$ ), nano Farad (nF), and picoFarad (pF).

### **Characteristics of a Capacitor:**

1. It can store electric charge even though the voltage source is already disconnected.
2. It can discharge electrical voltages.

### **Symbols of Capacitor**

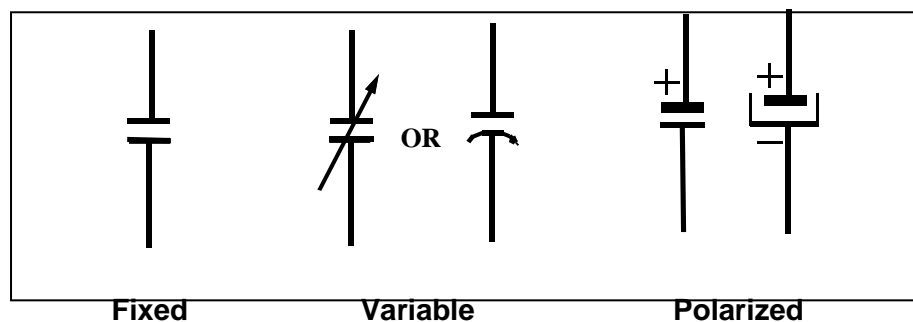

## Common Types of Fixed Capacitor

Aluminum Electrolytic Capacitors (polarized)					
					
Axial Leads	Radial Leads	Computer Grade	Snap Mount	Twist Lock	Surface Mount
Tantalum Capacitors (polarized)					
					
<u>Solid Tantalum</u> ( Axial Leads )	<u>Solid Tantalum</u> ( Radial Leads )	<u>Foil Tantalum</u> ( Axial Leads )	<u>Dipped Tantalum</u>	<u>Wet Tantalum</u>	<u>Surface Mount</u>
Ceramic Capacitors					
					
Dip guard	Monolithic (Axial Leads)	Monolithic (Radial Leads)	Disc	Surface Mount	
Film Capacitors					
					
Polyester (Axial Leads)	Polyester (Radial Leads)	Polypropylene (Axial Leads)	Polypropylene (Radial Leads)	Polystyrene (Axial Leads)	



**Variable capacitors used as tuning capacitor for radio receivers**

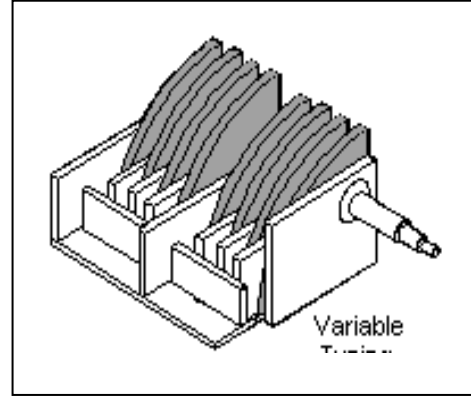

**1. Semiconductor Diodes**

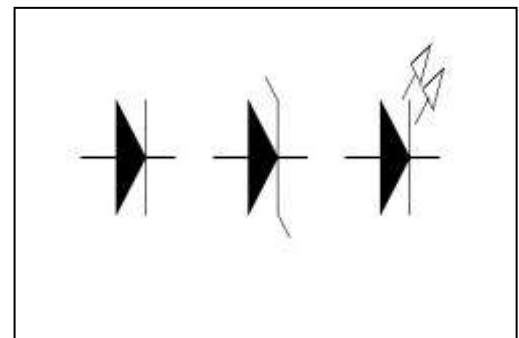
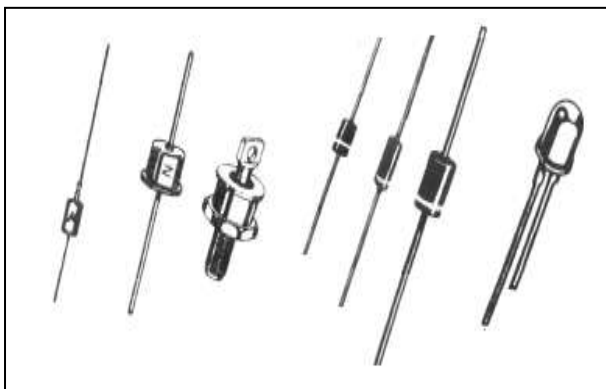

**Rectifier    Zener    LED**

**2. Bipolar Junction Transistors (BJT)**

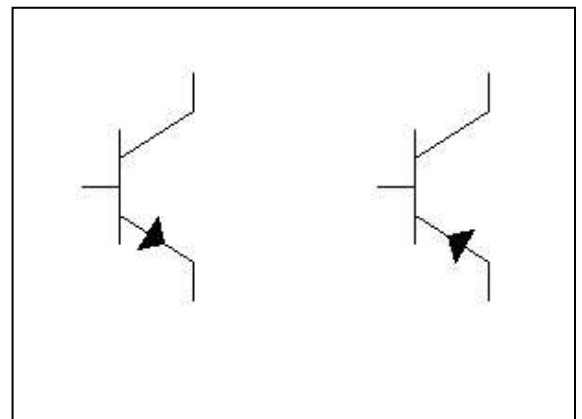
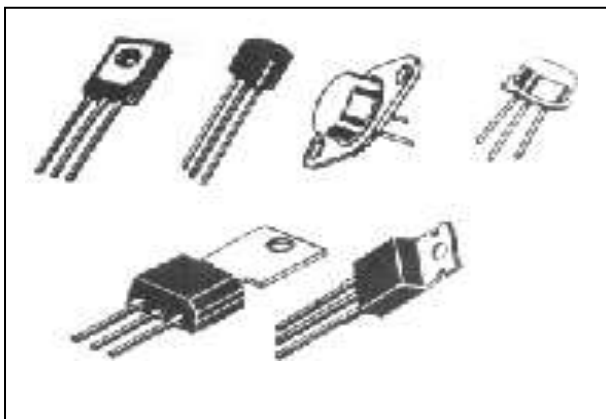

**PNP**

**NPN**

**Pictorial**

**Symbol**

### 3. Integrated Circuit (IC)

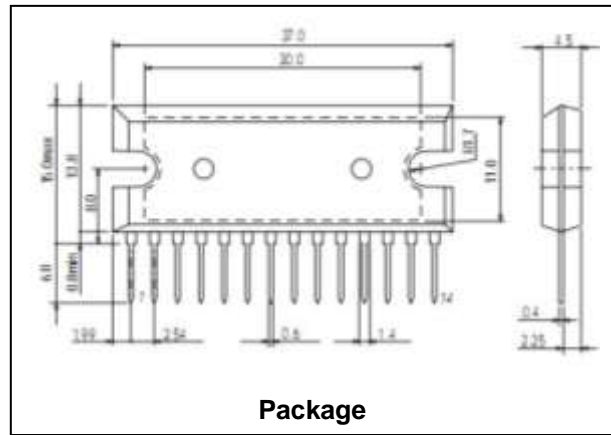
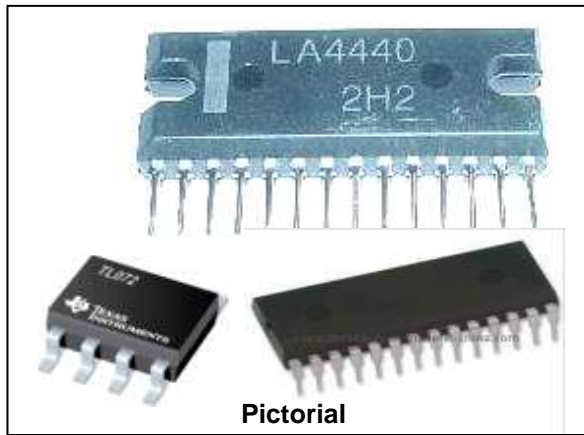



## How Much Have You Learned?

### Self-Check 2.1

**DIRECTIONS:** Draw the schematic symbol and physical appearance of the following electronic components and give the function(s) of each (Table 1-1).

**Table 1-1 Electronic Components**

Type / Symbol	Actual / Physical appearance	Uses / Application
1. NPN Transistor		
2. Zener diode		
3. Polarized capacitor		
4. Light-Emitting Diode (LED)		
5. PNP transistor		
6. Battery		
7. Variable capacitor		
8. Potentiometer		

**Refer to the Answer Key. What is your score?**

## LEARNING OUTCOME 2

### Interpret Technical Drawings

#### PERFORMANCE STANDARDS

- Components, assemblies or objects are recognized as required.
- Dimensions of the key features of the objects depicted in the drawing are correctly identified.
- Symbols used in the drawing are identified and interpreted correctly.
- Drawings are checked and validated against job requirements or equipment in accordance with standard operating procedure.



### What Do You Already Know?

Let us determine how much you already know about interpreting technical drawings. Take this test.

Pretest LO 2

**Directions:** Answer the following questions. Write the letter of the best answer.

1. A geometric figure usually used to represent a stage in a block diagram.  
A. Rectangle  
B. Circle  
C. Pentagon  
D. Hexagon
2. It is the process of illustrating various kinds of circuits and wiring systems.  
A. Reference designation  
B. Electronic Drafting  
C. Freehand drawing  
D. Mechanical drawing
3. It shows the relationship between the various component groups or stages in the operation of the circuit.  
A. Wiring diagram  
B. Block diagram  
C. Pictorial diagram  
D. Schematic diagram
4. Another name for connection diagram.  
A. Wiring diagram  
B. Block diagram  
C. pictorial diagram  
D. schematic diagram

5. It is a picture or a sketch drawn to show the component of a circuit and how These components are connected together.
- A. Wiring diagram
  - B. Block diagram
  - C. Pictorial diagram
  - D. Schematic diagram

Criteria for Evaluating Results of Pre-Test

100%-skip the Learning Outcome and proceed to the next Learning Outcome

99%-below – Go through the Learning Outcome



## What Do You Need To Know?

**Read Information Sheet 2.1 very well then find out how much you can remember and how much you learned by doing Self-check 2.1.**

### Information Sheet 2.1

All electronic circuits from the simplest to the most complex design need diagrams to be used as reference in designing, modifying, and troubleshooting the circuit. The most common used electronic diagrams are schematic, pictorial, wiring, and block diagrams. Each one of these diagrams has its own unique characteristics in presenting the circuit. The different diagrams that you should be familiar with are the following:

**Pictorial diagram** - It shows the pictures of the actual components and wiring connections although it does not provide the exact size of components. It shows exact shape in proportion to the actual component or device.

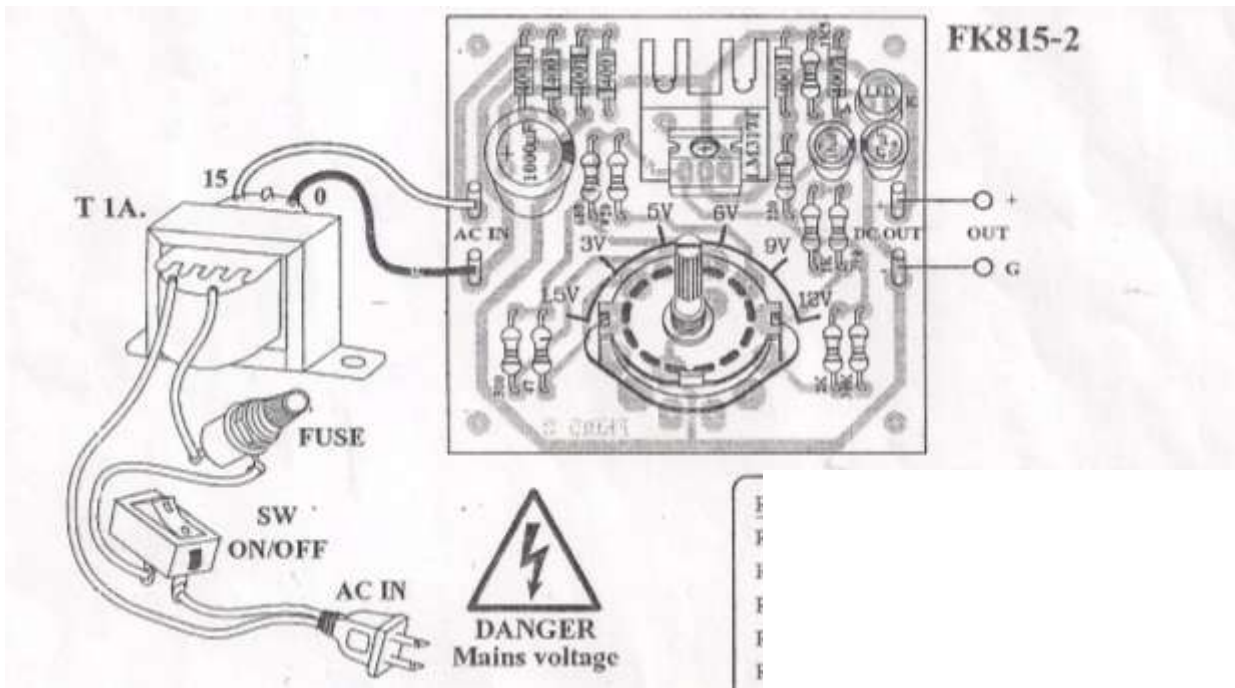

**Pictorial Diagram of a Regulated Power Supply**

**Block Diagram** – This form usually uses block of squares, rectangles or triangles to represent components, group of components or units of equivalent. Block diagrams are particularly used to represent internal components of an integrated circuit.

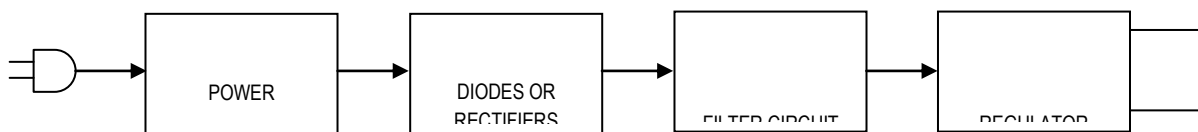

**Block Diagram of a Regulated Power Supply**

**Schematic diagram** – A diagram that shows the components used in their interconnection. Each graphic symbol is also accompanied with a reference designation to distinguish it from other similar symbols. It does not illustrate the physical size, shape or chassis location of the component parts and devices.

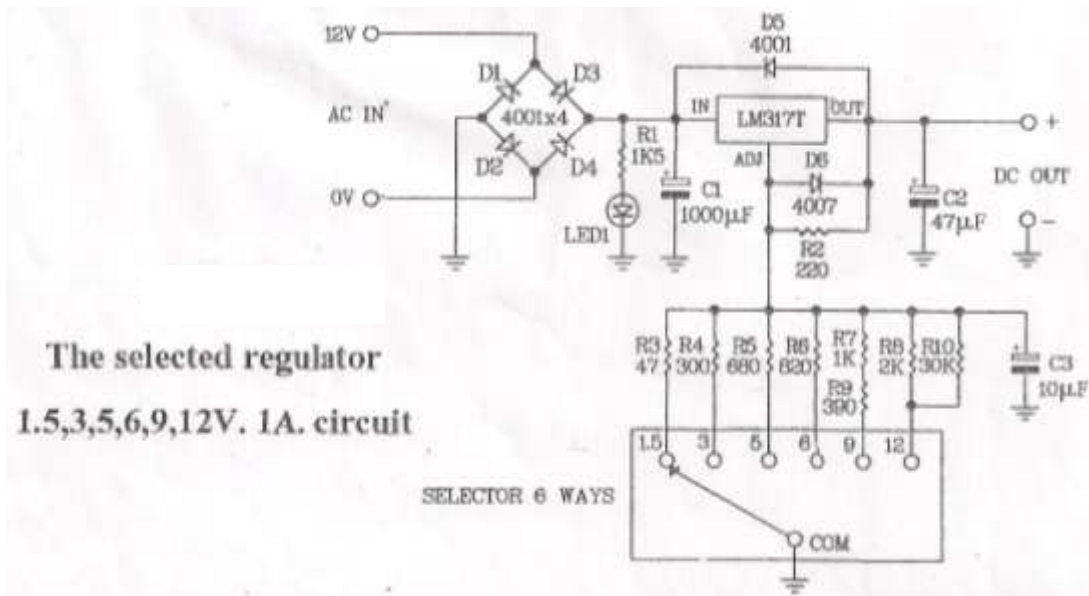

**Schematic Diagram of a Regulated Power Supply (power transformer is NOT shown)**

**Wiring diagram** – A diagram that shows wiring connection in a simplified, easy to follow manner. It may show either internal or external connections or both and is usually drawn as simple as possible to trace out the connection of a circuit. The components of the circuit are identified by name or are represented by means of pictorial illustrations that do not follow any well-defined standard form.

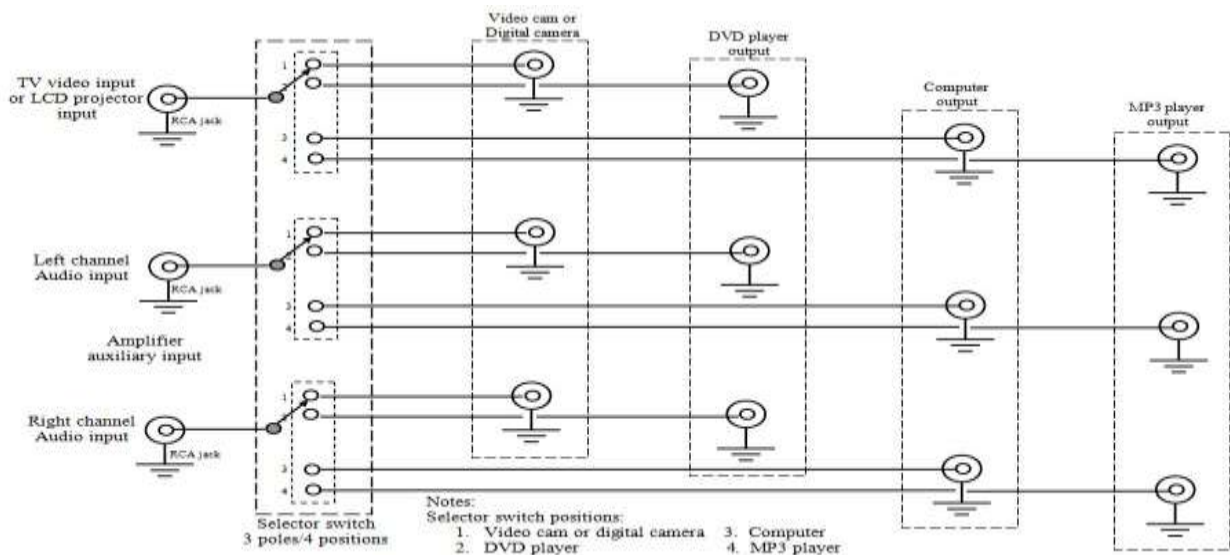

**Wiring diagram of a selector switch for different input multi-media equipment**



# How Much Have You Learned?

## Self-Check 2.1

**DIRECTIONS:** Shown below are different electronic diagrams. Write the name of the diagram in the space provided for at the bottom of each diagram.

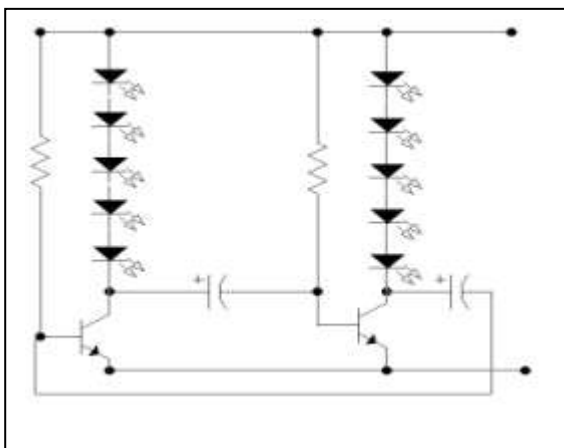

1. \_\_\_\_\_

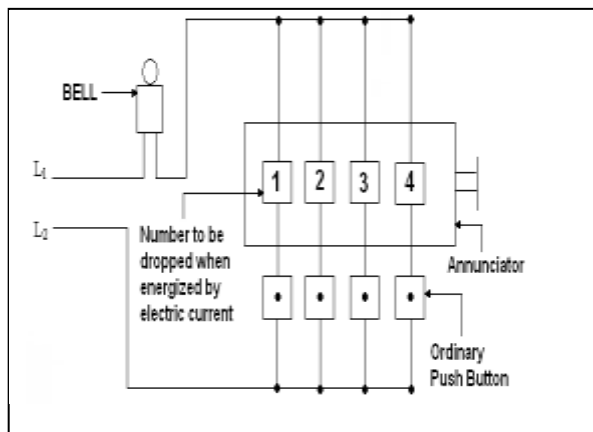

2. \_\_\_\_\_

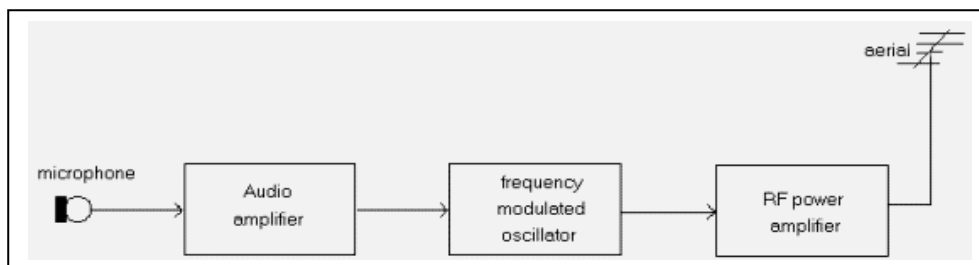

3. \_\_\_\_\_

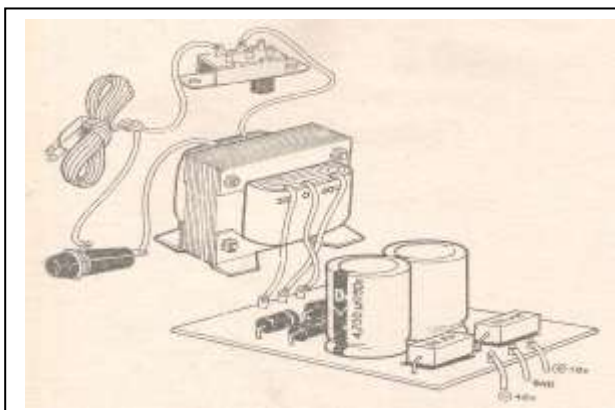

4. \_\_\_\_\_

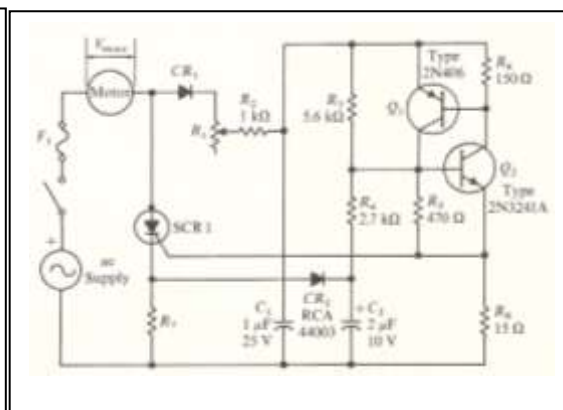

5. \_\_\_\_\_

**Refer to the Answer Key. What is your score?**



## LEARNING OUTCOME 3

### Prepare electronic diagrams

## PERFORMANCE STANDARDS

- Electrical/ electronic schematic diagrams are drawn and correctly identified.
- Correct drawings are identified, equipment are selected and used in accordance with job requirements



## What Do You Already Know?

Let us determine how much you already know about preparing electronic diagrams. Take this test.

Pretest LO 3

**Directions:** Answer the following questions. Encircle the letter of the best answer.

1. If the Greek letter Omega ( $\Omega$ ) appears in a schematic diagram, the component value being represented is a
  - A. Capacitor
  - B. Transistor
  - C. Transformer
  - D. Resistor
2. The labels of a capacitor C1A and C1B in a diagram are examples of \_\_\_\_\_.
  - A. Designated letters
  - B. Suffix letters
  - C. Subscript letters
  - D. Coefficient letters
3. These types of lines are used on schematic diagrams to show a mechanical linkage between components.
  - A. Dashed lines
  - B. Medium lines
  - C. Thick lines
  - D. Thin lines

4. One of these is NOT given in a schematic diagram
  - A. Wiring specifications
  - B. Point-to-point resistance values
  - C. Actual appearance of components
  - D. Operating instructions
5. The symbols on a schematic diagram are arranged so that the diagram can be “read” in this manner.
  - A. Top to bottom
  - B. Bottom to top
  - C. Right to left
  - D. Left to right

#### Criteria for Evaluating Results

100%-skip the Learning Outcome and proceed to the next Learning Outcome

99%-below – Go through the Learning Outcome



## What Do You Need To Know?

**Read Information Sheet 3.1 very well then find out how much you can remember and how much you learned by doing Self-check 3.1.**

### Information Sheet 3.1

One of the features of a quality electronic diagram is its appearance with simplicity in design and easy-to-understand layout. To achieve this, you have to follow the following standards in laying out electronic diagrams.

#### **Rules for Drawing Symbols**

Recommended practices to be used in the application of symbols to a circuit diagram are listed below.

1. The position of a symbol on a diagram does not affect its meaning.
2. The weight of a line used in drawing a symbol does not affect its meaning. In some cases, a heavier line may be used to emphasize a particular symbol.
3. A given symbol may be drawn in any size that is suitable for use in any particular diagram. However, when a symbol is enlarged or reduced in size, it should be drawn in proportion to the rest of the drawing.

4. If necessary for contrast, some symbols may be drawn smaller or larger than other symbols on a diagram. However, for simplicity, it is recommended that not more than two different sizes of symbols be used on any one diagram.
5. In general, a connecting line should be brought to a symbol either vertically or horizontally, but a connecting line brought to a symbol at an angle has no particular significance unless otherwise noted.
6. The arrowhead of a symbol may be open (  $\rightarrow$  ) or closed (  $\longrightarrow$  ) unless otherwise noted.
7. The standard symbol for terminal (o) may be added to any symbol. But when this is done, the terminal symbol should not be considered a part of the symbol itself.

### Reference Designations

The symbols used to represent various components on a circuit diagram are most often accompanied by a combination of letters that identify the components but are not themselves a part of the symbol (Table 3-1).

**Table 3-1. Reference Designations of Electronic Components**

Components	Class Designation Letter(s)
Capacitor	C
Diode	D
Resistor	R
Switch	S or SW
Transformer	T
Transistor	Q or TR

When more than one symbol of a specific type of component appears on a diagram, the letter (or letters) is followed by numbers that identify the components. These combinations of letters and numbers are referred to as reference designations (Fig. 3-1).

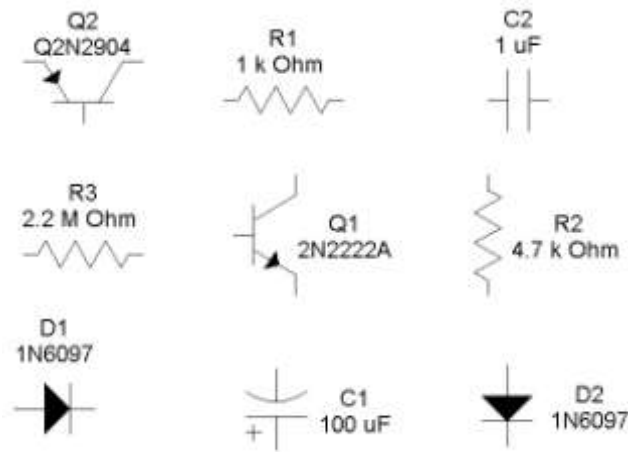

Fig. 3-1. Recommended methods of indicating reference designations and component values.

### Numerical Values of Components

When details of the type, rating or value of a particular component are to be given on a diagram, this information is placed adjacent to the symbol or is given by means of notes accompanying the diagram. For example, resistance and capacitance values are indicated as shown in Fig. 3-1. In this scheme, the symbol  $\Omega$  for ohms and the abbreviations  $\mu\text{F}$  and  $\text{pF}$  for capacitance values are usually omitted and are instead replaced by notes such as the following:

1. All resistors expressed in ohms unless otherwise indicated.
2. All capacitors expressed in microfarads unless otherwise indicated.

A resistance value of 1,000 ohms or more is most often expressed in terms of Kiloohm (K) or Meghm (M) units. Thus a resistance of 4,700 ohms is written as 4.7K, while a resistance of 270,000 ohms may be written as 270K or as 0.27M. The comma used when writing a 4-digit number such as 4,700 is not used when such a number is given on a diagram.

Capacitance values of 1 through 9,999 picofarads are usually expressed in picofarad units. Capacitance values greater than 10,000 picofarads should be expressed in microfarad units.

### Suffix Letters

Suffix letters are used to identify separate parts of a unit upon a diagram when such components appear as a single, enclosed unit as shown in Fig. 3-2.  $C_{1A}$  and  $C_{1B}$  are the suffix letters used in the diagram.

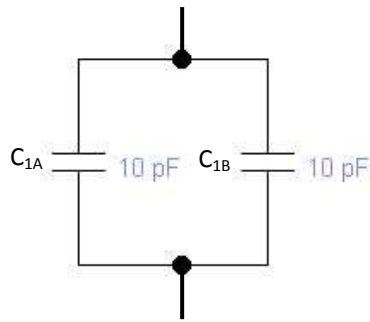

Fig. 3-2. Two capacitors are enclosed in one unit.

### Layout

The layout or form of a diagram should show the main features prominently. The parts of a diagram should be carefully spaced to provide an even balance between blank spaces and lines. Enough blank space should be left in the areas near symbols to avoid crowding any necessary notes or reference information (Fig. 3-3).

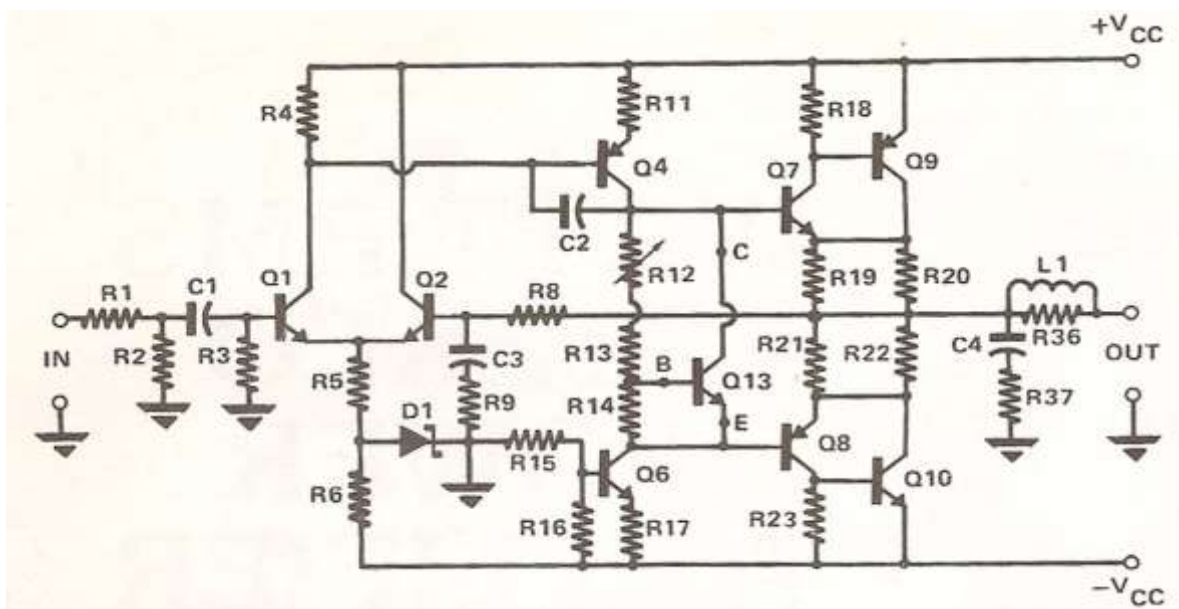







Fig. 3-3. Schematic diagram of an audio amplifier.

### Line Thickness

As with other types of diagrams, a schedule of line weights or line conventions is used in drawing electrical and electronics diagrams. The standard line conventions used in the preparation of these diagrams are shown in Table 3-2.

**Table 3-2.** Line thickness

Line application	Line thickness	
For general use	Medium	
Mechanical connection, shielding, and future circuits line	Medium	
Bracket-connecting dash line	Medium	
Brackets and leader lines	Thin	
Boundary of mechanical grouping	Thin	
For emphasis	Thick	

## Connecting Lines

Lines connecting symbols and other parts on a diagram should, whenever possible, be drawn either horizontally or vertically. As a general rule, no more than three lines should be drawn to any point on a circuit diagram (Fig. 3-4A). This procedure reduces the possibility of line crowding that could make the interpretation of a diagram more difficult than necessary.

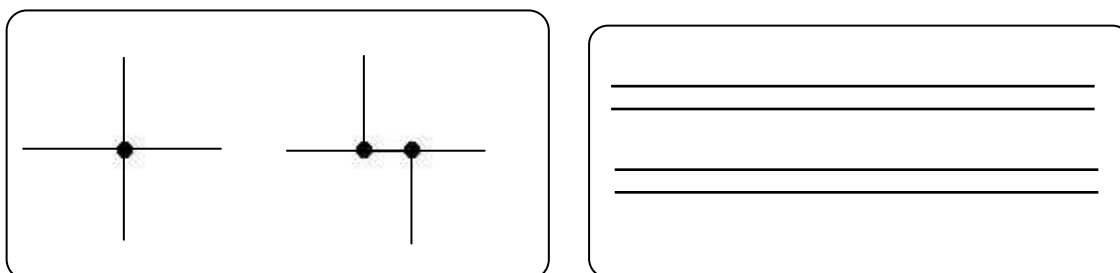

RECOMMENDED

(A)

AVOID IF POSSIBLE

(B)

Fig. 3-4. Connecting lines. (A) recommended and undesirable methods of drawing lines to a point upon a diagram, (B) two “groups” of connecting lines drawn parallel to each other.

When connecting lines are drawn parallel to each other, the space between them should be at least 1/16 inch when the diagram is reduced to a final size.

## Interrupted Lines

Connecting lines whether single or in groups, may be interrupted when a diagram does not provide for a continuation of these lines to their final destination. When a single line is interrupted, the line identification can also indicate the destination (Fig. 3-5A). When groups of lines are interrupted, the destination of the lines is usually given in conjunction with brackets (Fig. 3-5B). In all cases, the lines should be located as close as possible to the point of interruption.

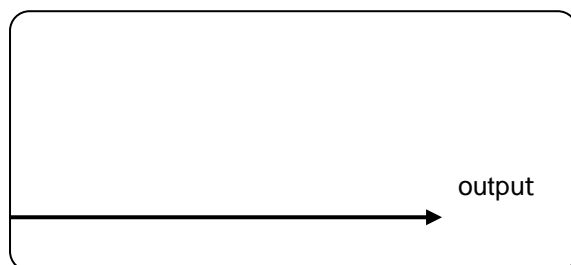

Fig. 3-5A.

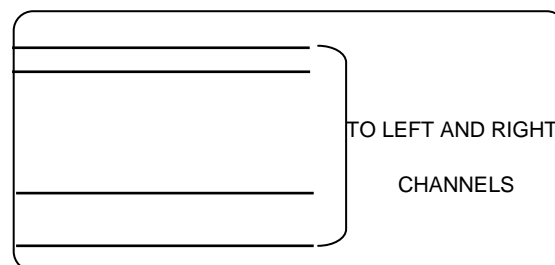

Fig. 3-5B.

Fig. 3-5. Methods of identifying the destination of single and grouped connecting lines.

## Dashed Lines

Dashed lines (-----) are used on schematic and other types of diagrams to show a mechanical linkage between components or parts of components (Fig. 3-6).

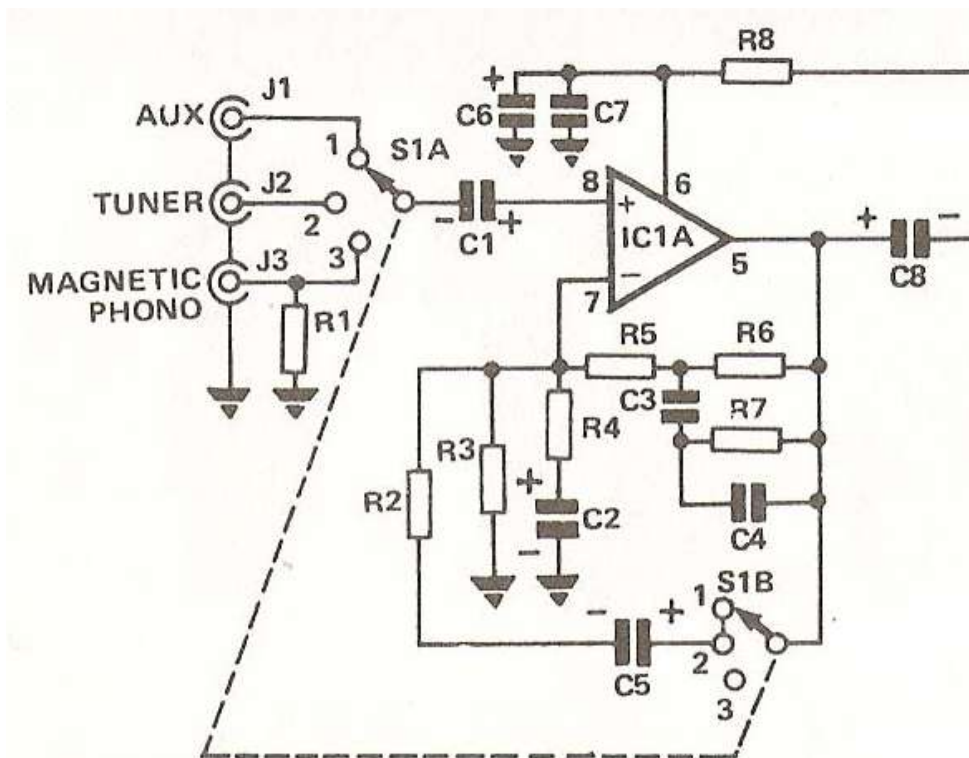

Fig. 3-6. Dashed lines are used to indicate the mechanical linkage of a 2-pole, 3-position selector switch.





## How Much Have You Learned?

### Self-Check 3.1

**DIRECTIONS:** Write the letter of the best answer on the space provided for before each number.

\_\_\_\_\_ 1. A letter designation is written near or beside a symbol to indicate what type of component that symbol is. The letter designation for transistor is \_\_\_\_\_.

- |      |      |
|------|------|
| A. Q | C. S |
| B. R | D. T |

\_\_\_\_\_ 2. These types of lines are used to show mechanical linkages between components or parts of components on schematic diagram.

- |                     |                 |
|---------------------|-----------------|
| A. Connecting lines | C. Medium lines |
| B. Dashed lines     | D. Thin lines   |

\_\_\_\_\_ 3. This punctuation mark is used to show the destination of grouped interrupted lines in a diagram.

- |            |                              |
|------------|------------------------------|
| A. Bracket | C. Open and close quotations |
| B. Comma   | D. Question mark             |

\_\_\_\_\_ 4. To avoid crowding of any necessary notes or reference information, enough blank space should be left in the areas near, which of the following elements on a schematic diagram should be considered?

- |                     |                 |
|---------------------|-----------------|
| A. Component labels | C. Dashed lines |
| B. Connecting lines | D. Symbols      |

\_\_\_\_\_ 5. In a schematic diagram, values of resistors are usually labeled in this unit otherwise noted by the manufacturer.

- |               |               |
|---------------|---------------|
| A. K $\Omega$ | C. Ohms       |
| B. M $\Omega$ | D. Resistance |

**Refer to the Answer Key. What is your score?**



## How Do You Apply What You Have Learned?

Show that you learned something by doing this activity.

### Operation Sheet 3.1

**I. Directions:** Using your electronic template, redraw the schematic diagram of a six-input mixer shown below. Label all components using the values listed as **parts list**. Be sure to follow the rules in drawing symbols.

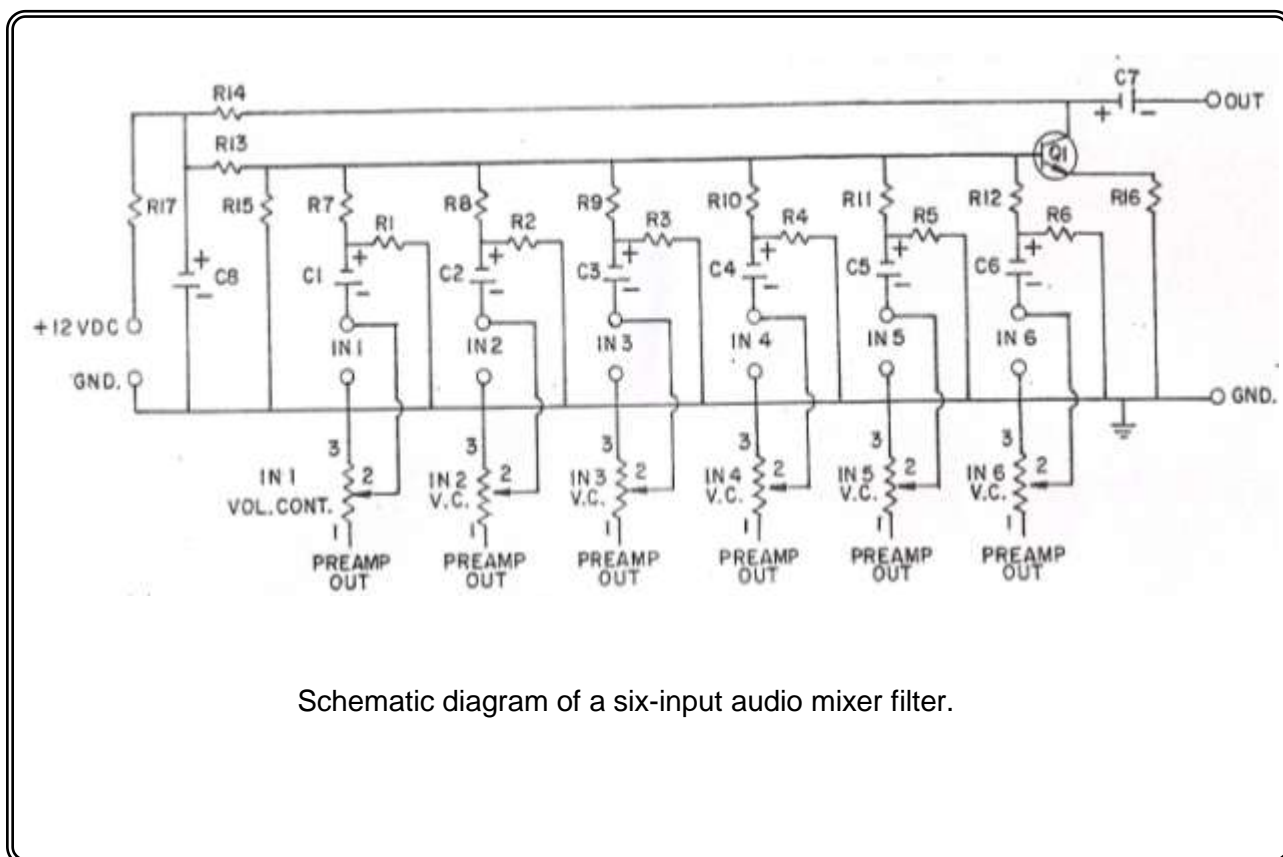

#### Parts list:

R1 – R6	= 22K $\Omega$	R16	= 68 $\Omega$
R7 – R12	= 39K $\Omega$	R17	= 1K $\Omega$
R13	= 100K $\Omega$	C1 – C6	= 10 $\mu$ F/16V
R14	= 2.2K $\Omega$	C7 – C8	= 47 $\mu$ F/16V
R15	= 6.8K $\Omega$	Q1	= 2SC945

II. Redraw the diagram of a 30-watt audio amplifier shown below applying the standard drafting practices. Label all components of the 30-watt audio amplifier using the values listed in the *parts list*.

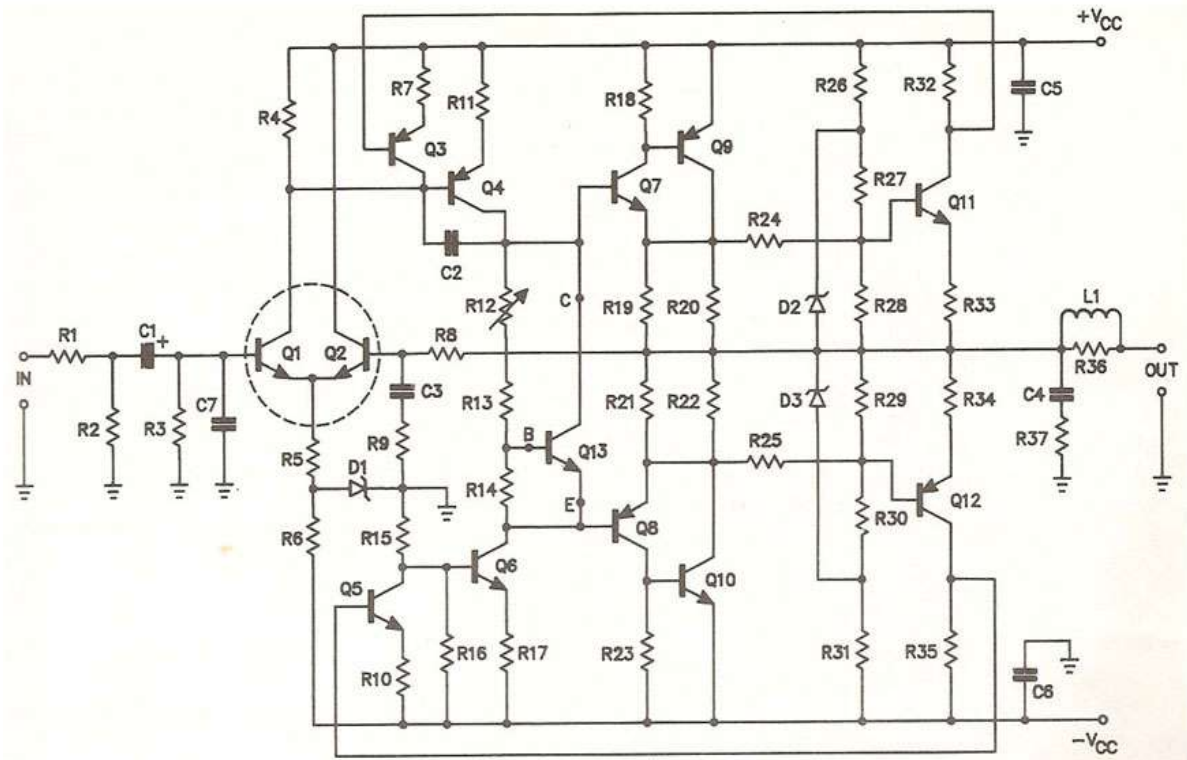

Schematic diagram of a 30-watt audio amplifier.

**Parts list:**

R1, R14 = 1K $\Omega$	R12 = 470 $\Omega$ trimmer	C1 = 10 $\mu$ F/10V	Q6 = MPSAS06
R2 = 100K $\Omega$	R13 = 560 $\Omega$	C2 = 0.001 $\mu$ F/50V	Q7 = 2N6717
R3, R8 = 10K $\Omega$	R15 = 27K $\Omega$	C3 = 50 $\mu$ F/10V	Q8 = 2N6729
R4 = 680 $\Omega$	R16, R27, R30 = 1.2K $\Omega$	C4, C5, C6 = 0.1 $\mu$ F/50V	Q9 = MJ2955
R5, R26, R31 = 5.6K $\Omega$	R17 = 120 $\Omega$	C7 = 0.002 $\mu$ F/50V	Q10 = 2N3055
R6 = 3.9K $\Omega$	R19, R20, R21, R22 = 1 $\Omega$	Q1, Q2 = MD8002	Q11 = MP5L01
R7, R10, R18, R2 = 100 $\Omega$	R24, R25, R32,	Q3 = MPSA70	Q12 = MP5L51
R9, R28, R29 = 470 $\Omega$	R33, R34, R35 = 330 $\Omega$	Q4 = MPSA56	Q13 = MJE3440
R11 = 10 $\Omega$	R36, R37 = 10 $\Omega$	Q5 = MPSA20	D1 = 1N5242B
			D2, D3 = 1N5236B

**III. DIRECTIONS:** Shown in Fig. 3-7A is a schematic diagram of a 50-watt booster amplifier and in Fig. 3-7B is its pictorial diagram. Redraw the pictorial diagram and write in Table 3-3 the name of components/devices indicated by arrows and give their functions.

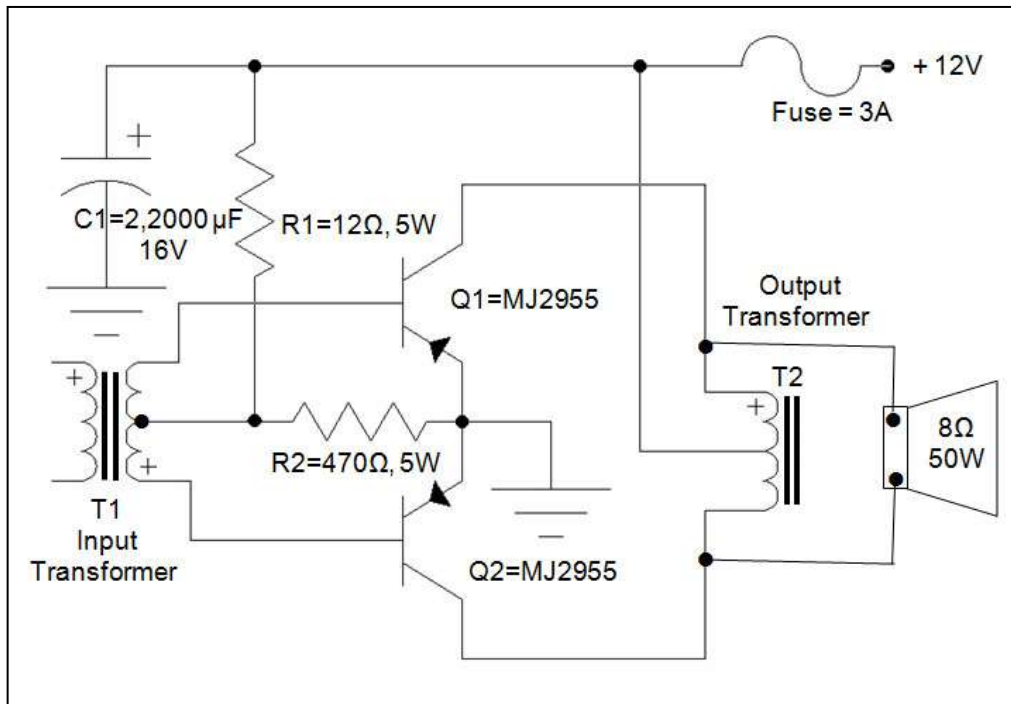

Fig. 3-7A. Schematic diagram of a 50-watt booster amplifier.

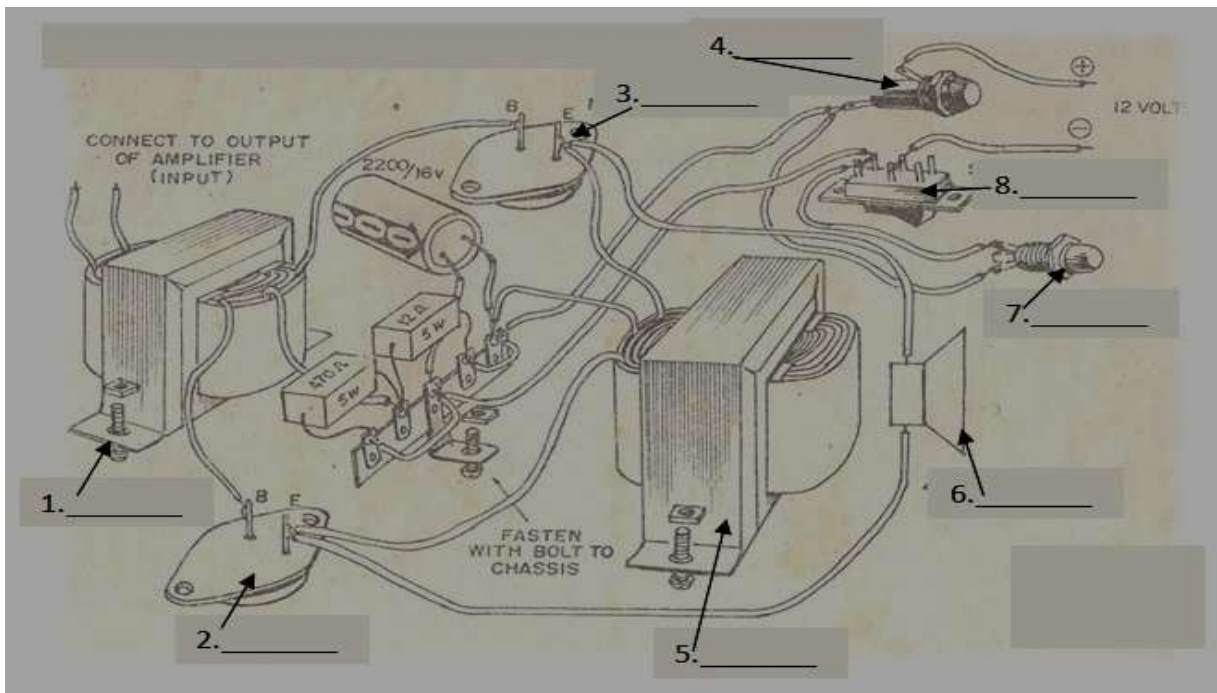
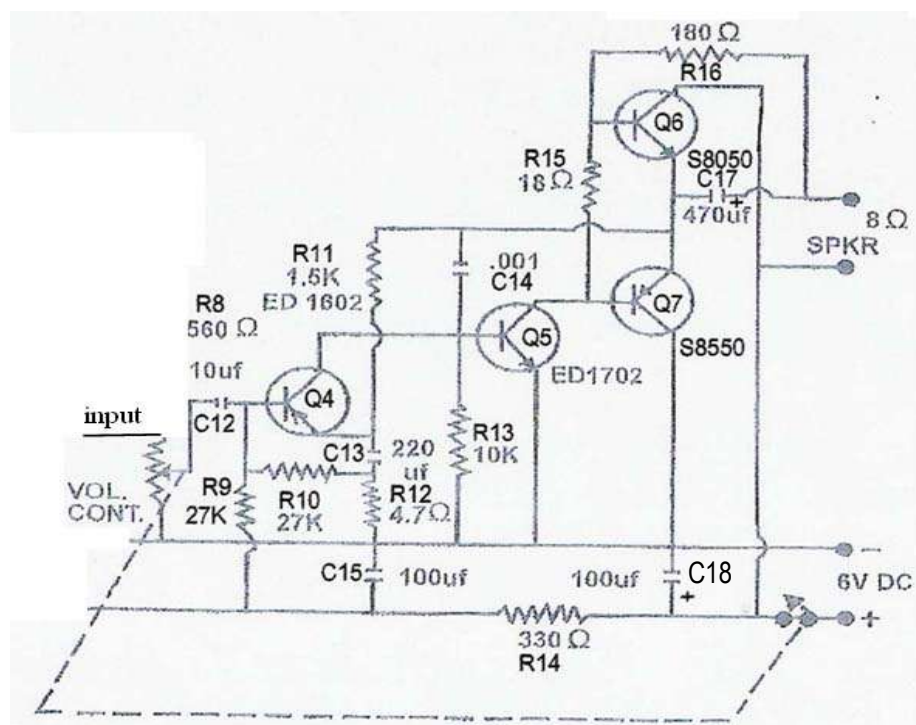

Fig. 3-7B. Pictorial diagram of a 50-watt booster amplifier.

**Table 3-3. Name of components, devices and their functions.**

Name of component/device	Function in the circuit
1.	
2.	
3.	
4.	
5.	
6.	
7.	
8.	

**IV. DIRECTIONS:** Redraw the diagram of a discrete audio amplifier of a typical AM radio receiver shown below **which is NOT properly drawn**. Be sure to make your diagram more presentable by following the Standard Drafting Practices.





## How Well Did You Perform?

**Find out by accomplishing the Scoring Rubric honestly and sincerely.  
Remember it is your learning at stake!**

### ASSESSMENT PLAN

**Directions:** Put a check on designated box if you observed the following criteria.

• <i>Get from assessment criteria of the module (CBC)</i>	<b>YES</b>	<b>NO</b>
<ul style="list-style-type: none"> <li>• Electronic components are specified according to their jobs.</li> <li>• Electronic components are identified based on their functions.</li> <li>• Electronic components which do not conform to the quality standard are identified and marked for disposal.</li> <li>• Electronic diagrams are identified according to job requirements.</li> <li>• The equivalent components of the electronic symbols are identified.</li> <li>• The connection of the electronic symbols in a circuit is identified</li> <li>• The symbols used are appropriate to the electronic components.</li> <li>• Electronic diagrams are drawn based on the requirements of the job.</li> <li>• The diagrams drawn provide all the specifications required by the job identified.</li> </ul>		

Prepared by:		Date:	
Checked by:		Date:	

### Observation Checklist

<b>Students name:</b>		
<b>Teachers name:</b>		
<b>Name of School</b>		
<b>Competency standards</b>		
<b>Unit of competency:</b>		
<b>Instructions for the teacher:</b>		
1. Observe the student <i>[insert description of activity being observed]</i> . 2. Describe the assessment activity and the date in which it was undertaken. 3. Place a tick in the box to show that the student completed each aspect of the activity in accordance with the standard expected in the enterprise. 4. Complete the feedback sections of the form.		
<b>Date of observation</b>		
<b>Description of assessment activity</b>		
<b>Location of assessment activity</b>		
<b>The Student.....</b>	<b>If yes, tick the box</b>	
•		
•		
•		
•		
•		
•		
•		
•		
•		
•		
•		
•		
•		
•		
Did the student overall performance meet the standard?	Yes	No
Feedback to student		
Teachers signature:	Date:	

### Observation and Questioning Checklist

<b>Student's name:</b>		
<b>Teacher's name:</b>		
<b>Assessment Center</b>		
<b>Competency standards</b>		
<b>Unit of competency:</b>		
<b>Instructions for the teacher:</b>		
<ol style="list-style-type: none"> <li>1. Observe the student <i>[insert description of activity being observed]</i>.</li> <li>2. Describe the assessment activity and the date on which it was undertaken.</li> <li>3. Place a tick in the box to show that the student completed each aspect of the activity in accordance with the standard expected in the enterprise.</li> <li>4. Ask the student a selection of the questions from the attached list to confirm his/her underpinning knowledge.</li> <li>5. Place a tick in the box to show that the student answered the questions correctly.</li> <li>6. Complete the feedback sections of the form.</li> </ol>		
<b>Date of observation</b>		
<b>Description of assessment activity</b>		
<b>Location of assessment activity</b>		
<b>The student....</b>	<b>If yes, tick the box</b>	
• <i>can</i>		
•		
•		
•		
•		
•		
•		
•		
Did the student's overall performance meet the standard?	Yes	No



## Demonstration

Students name:			
Teacher's name:			
Unit of competency:			
Competency standards:			
Date of assessment:			
Time of assessment:			
Instructions for demonstration			
Given the necessary materials the trainee/student must be able to:			
<b>Materials and equipment:</b>			
		✓ to show if evidence is demonstrated	
<b>During the demonstration of skills, did the student:</b>	<b>Yes</b>	<b>No</b>	<b>N/A</b>
	<input type="checkbox"/>	<input type="checkbox"/>	<input type="checkbox"/>
	<input type="checkbox"/>	<input type="checkbox"/>	<input type="checkbox"/>
	<input type="checkbox"/>	<input type="checkbox"/>	<input type="checkbox"/>
	<input type="checkbox"/>	<input type="checkbox"/>	<input type="checkbox"/>
The student's demonstration was:			
Satisfactory <input type="checkbox"/>		Not Satisfactory <input type="checkbox"/>	

## PERFORMANCE TEST

Student Name	Date
Competency:	Test Attempt 1st    2nd    3rd

<p><b>Directions:</b></p> <p>CALL TEACHER and ask him/her to assess your performance in the following critical task and performance criteria below</p> <p>You will be rated based on the overall evaluation on the right side.</p>	<b>OVERALL EVALUATION</b>	
	<b>Level</b>	
	<b>Achieved</b>	<b>PERFORMANCE LEVELS</b>
		4 - Can perform this skill without supervision and with initiative and adaptability to problem situations.
		3 - Can perform this skill satisfactorily without assistance or supervision.
		2 - Can perform this skill satisfactorily but requires some assistance and/or supervision.
		1 - Can perform parts of this skill satisfactorily, but requires considerable assistance and/or supervision.
Teacher will initial level achieved.		



## Written report

<b>Student's name:</b>			
<b>Teacher's name:</b>			
<b>Assessment Center</b>			
<b>Competency standards</b>			
<b>Unit of competency:</b>			
<b>Task:</b>			
Your task is to:			
<ul style="list-style-type: none"> <li>• <i>[insert description of task]</i></li> </ul>			
<b>Submission date:</b>			
<b>Use the checklist below as a basis for judging whether the student's report meets the required competency standards.</b>			
<b>The student's report...</b>		<b>If yes, tick the box</b>	
• <i>can solve quantities needed through percentage</i>			
• <i>can tabulate data correctly</i>			
• <i>can convert temperature to the required temperature scale</i>			
• <i>can fill in appropriate form completely and correctly</i>			
• <i>can identify proper method of sealing packed products</i>			
• <i>can label correctly packed products</i>			
Overall did the student's report meet the standard?		Yes	No
Comments:			
<b>Student's signature:</b>		<b>Date:</b>	
<b>Teacher's signature:</b>		<b>Date:</b>	



**Congratulations! You did a great job! Rest and relax a while then move on to the next lesson. Good luck!**

## REFERENCES

- Enriquez, Marcelo T. Electronics Technology IV; Souvenir Publications, Inc.: 2003
- L Tan, Michael Q., Gantalao, Fred T., Lasala, Rommel M. Simple Electronics; Andes Mountain Printers: 2004

## LESSON 4

### Practice Occupational Health and Safety



#### LEARNING OUTCOMES:

At the end of this Lesson, you are expected to do the following:

- LO 1. identify health hazards and occupational risks; and
- LO 2. observe occupational and safety practices.



## Definition of Terms

**Electronics Laboratory** - a place where activities *pertaining* to electronics projects are done

**Electric shock** - a sudden discharge of electricity

**Electrostatic discharge** - releasing of the electrical charges produced by the human body to **ground**

**Gloves** - covering of leather, cotton, silk, etc for the hand usually with separated fingers.

**Goggle** - spectacles for protecting eyes from glare, dust, and other pollutants.

**Hazard** - something causing danger

**Mask** - covering for concealing the face

**Maintenance** - keeping up with an A1 operation

**Occupational health** - pertaining to wellness of an individual with reference to an activity or **job** in any of the workplace identified

**Personal Protective Equipment - (PPE)** equipment used to protect one's body from hazards and danger of the electronics trades

**Risk** - exposure to something unpleasant

**Safety practices** - set of rules or procedures intended for a safe execution of a certain activity or job in a laboratory

**5S** - five actions that start with letter S that helps in the arrangement of things in a laboratory *Systematize. Sort, Sweep, Self discipline, Sanitize*

**Systematize** – to arrange methodically things in a laboratory

**Standardize** - to make things in same features or level in quality or achievement

**Sort** - arrange things according to kinds, types, or classification

**Injury** - damage or harm to the structure or function of the body caused by an outside agent or force, which may be physical or chemical

**Cuts** - break in the skin inflicted by sharp objects

**Burns** - damage in the skin caused by exposure to fire or excessive heat

**Fire extinguisher** - an equipment of chemicals intended to terminate or extinguish fire

**First Aid Kit** – a kit containing medicine for initial treatment of any wounds inflicted to a person

## LEARNING OUTCOME 1

### Identify health hazards and occupational risks

#### PERFORMANCE STANDARDS

- Health hazards and occupational risks are identified.
- Safety nets are formulated and installed.
- Protective equipment are identified.
- Occupational health and safety practices are observed



### What Do You Already Know?

Let us determine how much you already know about identifying health hazards and occupational risks. Take this test.

Pretest LO 1

**Directions:** Choose the best answer. Write letters only.

1. What is the equipment that is used to discharge electrical charges produced by the human body?  
A.) Audio Generator  
B) Signal Generator  
C) ESD  
D) VOM
2. What is the term for an exposure to unpleasant situation?  
A) Chance  
B) Opportunity  
C) Danger  
D) Risk
3. What are the set of rules or practices intended for a safe execution of work?  
A) Safety practices  
B) Rules and regulations  
C) Policy order  
D) Action plan
4. What tools are not recommended to be used in electronics work?  
A) Brand new tools  
B) Branded tools  
C) Damaged tools  
D) Standard tools
5. What is the best place for electronic hand tools and equipment?  
A) Tool box  
B) Tool cabinet  
C) Tool room  
D) Tool bag





## What Do You Need To Know?

Read Information Sheet 1.1 very well then find out how much you can remember and how much you learned by doing Self-check 1.1.

### Information Sheet 1.1

In every field of work, there are safety precautions and practices to be followed to prevent accidents. Sometimes before an accident occurs a warning is given, so the individual concerned can prepare for the undesirable eventualities. In some situations, no warning at all is served and anyone is caught by surprise.

In areas where students are acquiring basic technical skills safety begins the moment they enter the work area or even before reaching that work area. Identifying health hazards and occupational risks is indispensable. In laboratory areas where students stay to acquire skills there are certain points to consider.

1. Electrical hazards. Electrical hazards are the type of risks that are more likely fatal than any other hazards that can happen in a laboratory room. Electrical hazards such as electrical shocks from open wires, grounded electrical appliances can be found anywhere in a disorganized laboratory area.



2. Hazards from improper use of hand tools. Hand tools are classified into cutting tools, driving tools, boring tools, joining tools, and measuring tools.

Cutting tools may inflict injuries when improperly handled due to their sharp edges that can cut through the skin of the human body.



### Driving tools

Driving tools like screw drivers and hammers, when used improperly can break human flesh or fracture bones which are very painful to an individual.



## Boring tools

Drill bits, Center punch, and reamer are boring tools. These tools also do damage when not properly used.



Electric drill



Drill bits with handle

## Soldering tools

Soldering tools such as soldering iron, soldering gun, and hot air soldering cause extreme heat and can burn the skin when improperly used.



Soldering iron



Soldering gun

Other hazards and risks can be caused by objects not properly placed in laboratory area where crumbling or falling is highly possible.



Objects placed on top of a cabinet can be very dangerous to students and teachers as well.

Other untoward incidents can also happen as a result of haste and sometimes neglect of tools, materials, and equipment in the shop. Disorderliness can also make things worse, hence presence of mind, particularly while working is important. It is very useful to follow guidelines that will serve as a safety net.

### **TOOLS MAINTENANCE and SAFETY RULES**

Tools will last longer when properly kept and maintained. A good worker keeps and cares for his tools. The following are some pointers to follow in keeping hand tools in good condition.

1. Be sure to inspect tools before using them. This is to check if they are in good working condition. The evidence is when you are able to use them smoothly and conveniently with ease and comfort.
2. After using a tool, clean it thoroughly with a damp cloth before keeping it in a tool box or cabinet.
3. Oil the metal parts of a tool to prevent any form of damage caused by air, water, or rust.

**The following safety rules should be understood and strictly followed to avoid accidents while working.**

1. Avoid wearing loose clothing when working. Sleeves should be fit and shirts tucked in as much as possible. Remove ties, watches, rings, and other jewelry from your body.
2. Report immediately injuries or accidents of any type to your teacher.
3. Never put fasteners or any small metal articles in or near your mouth when working.
4. Never throw tools of any type around. Make sure the sharp edge of cutting tools are away from the edge of the table or work bench.
5. Keep working areas clean and free from disposable materials.
6. Secure the help of your classmates when carrying heavy tools to avoid accidents.
7. Never use dull or damaged tools.
8. Do not use tools with loose handles and ragged. Report cases like these to the teacher and do the necessary repair and adjustments, if possible.
9. Know and observe safety measures specific for each tool or operation.

### **Safety Requirements**

For your protection, observe the following safety requirements:

- Follow all cautions, warnings, and instructions marked on the equipment.
- Ensure that the voltage and frequency rating of the power outlet matches the electrical rating labels on the system.
- Use properly grounded power outlets.

## **Safety Requirements with the Use of Personal Protective Equipment**

## Hand Tool Design, Selection, and Setup

1. **Weight** - Use the lightest weight tool possible to avoid injury. Excessively heavy tools must be equipped with mechanical support and attached hoses should be supported.

Support - Equip tools with some means of mechanical support so you don't need to hold a heavy tool continuously while working. If mechanical support cannot be provided, the workstation should be designed so you can put the tool down or rest it in a holster when it is not in use.

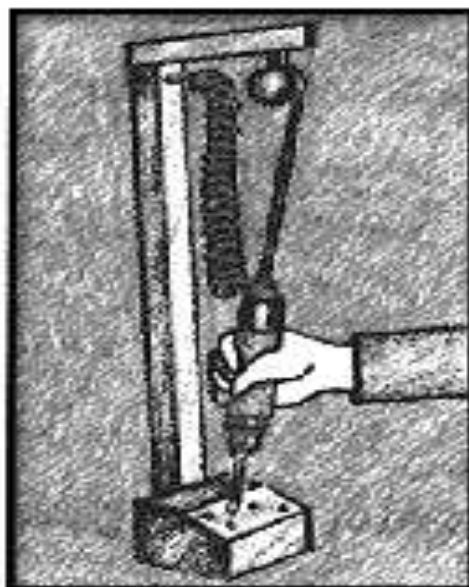

2. **Balance** - Additional force is required to use an unbalanced tool. The tool's center of gravity should be close to the body, close to the handles, and in line with the center of the hand holding the tool.

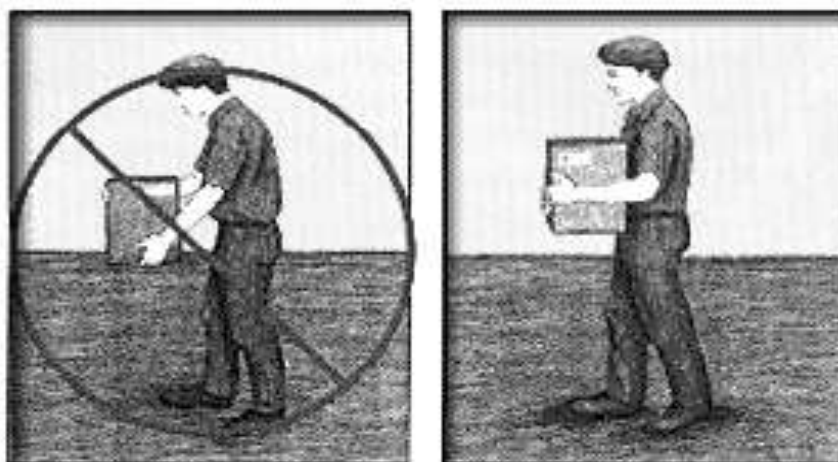

3. **Torque Control** - High torque requires a lot of force to keep the tool from rotating out of your hand. Torque settings should be set to the minimum required by job specifications, especially for in-line and pistol-shaped tools.



4. **Grip** - Tool handles should allow stable and efficient grip. The handle should be cylindrical or oval in shape, with a diameter of between 1.25 and 1.75 inches. Tool handles should contact as much of the hand and fingers as possible. Grips should be made of non-slip compressible and non-conductive material. Avoid form-fitting handles (handles with finger grooves), since they may not fit the hand size of every user. Handles should be kept clean and free from slippery grease, oil, or sweat.

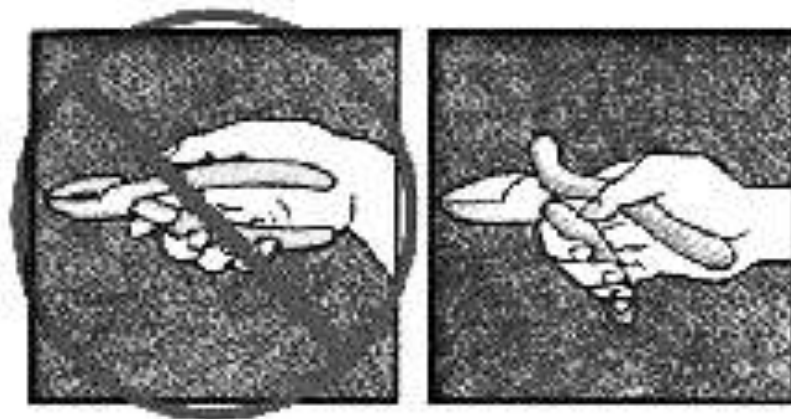

5. **Span** - On two-handed manual tools, like pliers, the open span should be about 4 inches and the closed span should only be about 1.5 inches.



6. **Spring-loaded handles** - A spring-loaded mechanism saves muscular effort and reduces mechanical stress on the backs and sides of fingers for such tools as scissors, pliers, and other manual cutting and gripping tools which have to be opened and closed repeatedly during use.
7. **Choose the right tool shape** - Pistol-shaped tools should be used on a vertical surface or on a horizontal surface below waist height. Bend the tool, not the wrist.

8. **Avoid bending over your work.**





9. Avoid overhead work if possible. Use a ladder to reduce the need for outstretched arms.



10. Keep the elbows close to the body.



11. Tilt the work surface instead of the wrist.



12. Stand with weight evenly distributed on both feet. When standing for long periods of time, rest one foot on a sturdy object above floor height and switch legs periodically.



13. Sit up straight so the chair offers good back support. Adjust the chair back so it comfortably supports the natural curve of the lower back. Adjust the seat height to allow thighs to be parallel to the floor.





# How Much Have You Learned?

## Self-Check 1.1

**Directions:** Write the safety requirement indicated in each number on a separate sheet of paper

1.



2.



3.



4.

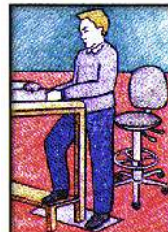

5.





## How Do You Apply What You Have Learned?

Show that you learned something by doing this activity

Operation Sheet 1.1

### Safety Requirements with the Use of Personal Protective Equipment

#### Instruction:

1. Without looking at Information Sheet 1.1, answer the written test on the safety requirements in using hand tools and test equipment in Self-Check 1.1.
2. After finishing your test, you can compare your answer with Answer Key 1.1.
3. You must get a score of 7 - 9 to get a grade of Very Good and pass the self-check based on Assessment Criteria 1.1.

Operation Sheet 1.2

Objective: To arrange tools and equipment in a tool cabinet according to the tools' classification.

Materials, Tools and Equipment:

- Assorted basic electronic hand tools and equipment
- Tool cabinet
- Paper
- Marking pen

Procedure:

1. Make a list of electronic hand tools and equipment.
2. Sort electronic hand tools according to their function.
3. Place electronic hand tools in separate areas in the cabinet according to their function.
  - a. Soldering tools
  - b. Cutting tools
  - c. Boring tools
  - d. Bending tools
  - e. Measuring tools
4. Label the areas according to functions of tools.
5. Locate tools that are defective.
6. Make an inventory of the tools and equipment according to function and label the status of the tools and equipment.

## Operation Sheet 1.3

**Objective:** To evaluate an electronics room as to the status of health hazards and occupational risks.

**Materials, Tools, and Equipment:**

1. Electronics Room
2. Laboratory tables with electrical wiring
3. Tool cabinet/ Tool room

**Instructions:**

1. Evaluate an electronics room as to the following:
  - Health hazards in the laboratory tables
  - Health hazards in the tool room/tool cabinet
  - Occupational risks when using electronics equipment



## How Well Did You Perform?

**Find out by accomplishing the Scoring Rubric honestly and sincerely.  
Remember it is your learning at stake!**

### Assessment Criteria 1.1

Score	Descriptive Grade
5	Excellent
4	Very good
3	Good
1-2	Fair
0	Poor

## PERFORMANCE TEST

Learner's Name	Date												
Competency:	Test Attempt 1st      2nd      3rd												
<p><b>Directions:</b></p> <p>CALL TEACHER and ask him/her to assess your performance in the following critical task and performance criteria below</p> <p>You will be rated based on the overall evaluation on the right side.</p>	<p style="text-align: center;"><b>OVERALL EVALUATION</b></p> <table border="1" style="width: 100%; border-collapse: collapse;"> <thead> <tr> <th style="width: 15%; padding: 5px;">Level Achieved</th> <th style="padding: 5px;">PERFORMANCE LEVELS</th> </tr> </thead> <tbody> <tr> <td style="width: 15%;"></td> <td style="padding: 5px;">4 - Perform this skill without supervision and with initiative and adaptability to problem situations.</td> </tr> <tr> <td></td> <td style="padding: 5px;">3 - Perform this skill satisfactorily without assistance or supervision.</td> </tr> <tr> <td></td> <td style="padding: 5px;">2 - Perform this skill satisfactorily but requires some assistance and/or supervision.</td> </tr> <tr> <td></td> <td style="padding: 5px;">1 - Perform parts of this skill satisfactorily, but requires considerable assistance and/or supervision.</td> </tr> <tr> <td colspan="2" style="text-align: center; padding: 5px;">Teacher will initial the level achieved.</td> </tr> </tbody> </table>	Level Achieved	PERFORMANCE LEVELS		4 - Perform this skill without supervision and with initiative and adaptability to problem situations.		3 - Perform this skill satisfactorily without assistance or supervision.		2 - Perform this skill satisfactorily but requires some assistance and/or supervision.		1 - Perform parts of this skill satisfactorily, but requires considerable assistance and/or supervision.	Teacher will initial the level achieved.	
Level Achieved	PERFORMANCE LEVELS												
	4 - Perform this skill without supervision and with initiative and adaptability to problem situations.												
	3 - Perform this skill satisfactorily without assistance or supervision.												
	2 - Perform this skill satisfactorily but requires some assistance and/or supervision.												
	1 - Perform parts of this skill satisfactorily, but requires considerable assistance and/or supervision.												
Teacher will initial the level achieved.													

<b>PERFORMANCE STANDARDS</b>	<b>Yes</b>	<b>No</b>	<b>N/A</b>
<b>For acceptable achievement, all items should receive a "Yes" or "N/A" response.</b>			
1. Identify health hazards and occupational risks in the working place.			
2. Identify health hazards and occupational risks in the arrangement of tools and equipment.			
3. Identify health hazards and occupational risks in the manner of handling tools and equipment.			
4. Identify health hazards and occupational risks in laboratory's electrical wiring system.			
5. Identify health hazards and occupational risks in the structure of the laboratory room.			



## How Do You Extend Your Learning?

Objective: To reinforce the knowledge and skills acquired in the information sheet, job sheet, and operation sheet.

1. Prepare a tools and equipment maintenance chart. Inspect all tools and equipment found in your shop room.
2. Indicate which ones need cleaning, repairing, rearranging, and labeling.
3. Determine what safety devices are found in your shop.
4. Identify health hazards and occupational risks found in your shop room.

## LEARNING OUTCOME 2

**Observe occupational health and safety practices**

### PERFORMANCE STANDARDS

- Measure advancing occupational health are observed.
- Safety Procedures are practiced.



## What Do You Already Know?

**Let us determine how much you already know about observing occupational health and safety practices. Take this test.**

Pretest LO 2

**Directions:** Modified true or false. Write true if the statement is true. If it is not true, write the word or words that make the statement false.

1. As a general rule, all passages must be free of any obstruction that will hamper the movement of persons in the area.
2. Treat every wire in the electrical system as live wire and act accordingly. Always attempt to work in any “live” electronic or electrical circuits.
3. Never use tools or equipment you are not familiar with or you do not know how to operate. Always ask assistance from your teacher to avoid accidents.
4. The shop is a place of work so one can engage in a play while at work.
5. Keep the work area always clean and orderly.





## What Do You Need To Know?

**Read Information Sheet 2.1 very well then find out how much you can remember and how much you have learned by doing Self-check 2.1.**

### Information Sheet 2.1

In the process of observing occupational health and safety practices, measures must be set to be followed by the students. Particularly, an electronics lab has these measures to highlight the manner of observing safety practices.

1. As a general rule all passages must be free of any obstruction that will hamper the movement of persons in the area. This provision also provides safety during emergency situations like fire and earthquake.
2. Treat every wire in the electrical system as live wire and act accordingly. Never attempt to work in any “live” electronic or electrical circuits.
3. All tools and equipment must be checked to be in A1 condition before they are lent to users.
4. All instructions must be centralized and must emanate from the person-in-charge.
5. The shop is a place of work, so do not engage in a play while at work.
6. Never use tools or equipment you are not familiar with or you do not know how to operate. Always ask assistance from your teacher to avoid accidents.
7. Keep hand tools such as screw driver, files, and pliers on the table or tool cabinet and not in your pocket as it might hurt you or other people.
8. Use only tools that are in good condition.
9. Report accidents and injuries to your teacher no matter how minor.
10. Keep the work area always clean and orderly.

In every field of life whether in school, industries, and elsewhere, the observance of safety is a must. There are basic safety guidelines to prevent minor injuries such as cuts, burns, electrical shock and damage to eyesight as well as the loss of human lives. As a good practice, make sure that a fire extinguisher and a first aid kit are available in case of injury or even fire.

### **Personal Safety Guidelines**

These are general guidelines for all types of troubleshooting, installation and maintenance tasks. Take them seriously. They may keep you out of a dangerous situation.

1. Never work alone in any electronics project. Always have someone to keep an eye out for any potential problem.
2. Always use protective eyewear or safety goggles when appropriate.
3. Do not go barefoot when moving tool boxes or laboratory equipment.
4. Never assume that an electrical device is safe to handle. Perform your test with the device disconnected from the power source.
5. Some tests must be connected with power applied. Be extremely cautious when performing these tests.
6. Do not wear jewelry of any kind while performing works in the laboratory.



## How Much Have You Learned?

### Self-Check 2.1

**Directions:** Modified TRUE or FALSE. Write true if the statement is true. If it is not true, write the word or words that make the statement false.

1. As a general rule, all passages must be free of any obstruction that will hamper the movement of persons in the area.
2. Treat every wire in the electrical system as live wire and act accordingly. Always attempt to work in any “live” electronic or electrical circuits.
3. Never use tools or equipment you are not familiar with or you do not know how to operate. Always ask assistance from your teacher to avoid accidents.
4. The shop is a place of work so one can engage in a play while at work.
5. Keep the work area always clean and orderly.

**Refer to the Answer Key. What is your score?**



## How Do You Apply What You Have Learned?

**Show that you have learned something by doing this activity.**

### Operation Sheet 2.1

Materials, Tools and Equipment:

Electronic components  
Electric wires  
Basic hand tools  
Measuring equipment  
Working tables  
Chairs and other lab facilities

Procedure:

1. Arrange electronic components based on safety considerations.
2. Arrange the basic hand tools together in a tool cabinet as to facilitate the measures regarding tools for occupational health and safety practices.
3. Arrange electrical wires according to standard safety measures.
4. Arrange electronic equipment considering occupational health and safety standards.
5. Arrange lab tables, chairs, and other related facilities in line with standard occupational health and safety practices.
6. Prepare an occupational health and safety practices report according to the result of the operation made.

### Operation Sheet 2.2

Materials, Tools, and Equipment:

Meter for measurement  
Drawing papers  
A laboratory room  
Laboratory tables, chairs  
Tool cabinet

Instructions:

Using a meter, measure the dimension of the laboratory room and other facilities and make a layout of your room. Review the set occupational health and safety practices and relate it to the existing shop layout.

Using your observation and analyses, draw a proposed layout of your shop room showing the flow of shop activities focusing on occupational health and safety practices.



## How Well Did You Perform?

**Find out by accomplishing the Scoring Rubric honestly and sincerely. Remember it is your learning at stake!**

### PERFORMANCE TEST

Learner's Name		Date		
Competency:		Test Attempt		
		1st	2nd	3rd
<p><b>Directions:</b></p> <p>CALL TEACHER, ask him/her to assess your performance in the following critical task and performance criteria below</p> <p>You will be rated based on the overall evaluation on the right side.</p>	<b>OVERALL EVALUATION</b>			
	Level			
	Achieved	<b>PERFORMANCE LEVELS</b>		
		4 - Perform this skill without supervision and with initiative and adaptability to problem situations.		
		3 - Perform this skill satisfactorily without assistance or supervision.		
		2 - Perform this skill satisfactorily but requires some assistance and/or supervision.		
	1 - Perform parts of this skill satisfactorily, but requires considerable assistance and/or supervision.			
Teacher will initial the level achieved.				

<b>PERFORMANCE STANDARDS</b>			
<b>For acceptable achievement, all items should receive a "Yes" or "N/A" response.</b>	<b>Yes</b>	<b>No</b>	<b>N/A</b>
1. Perform occupational health and safety practices with respect to the movement in the laboratory.			
2. Perform occupational health and safety practices in the arrangement of basic hand tools and equipment.			
3. Perform occupational health and safety practices in the arrangement of wires in the laboratory area.			
4. Manifest danger in the arrangement of facilities in the laboratory area.			
5. Suggest laboratory set-up based on the standard occupational health and safety practices.			



**Congratulations! You did a great job! Rest and relax a while then move on to the next lesson. Good luck!**

## REFERENCES

- Enriquez, Marcelo T., Electronics Technology IV; Souvenir Publications, Inc. 2003
- Grob, Bernard, Basic Electronics, 4<sup>th</sup> Edition; New York: McGraw-Hill Company, USA: 1982
- Tan, Michael Q.; Gantalao, Fred T.; Lasala, Rommel M. Simple Electronics; Andes Mountain Printers; 2004

## LESSON 5

### Maintain Tools and Equipment



#### LEARNING OUTCOMES:

At the end of this Lesson, you are expected to do the following:

- LO 1. maintain hand tools and equipment; and
- LO 2. perform basic preventive maintenance of electronic tools and equipment.



## Definition of Terms

**Soldering iron** - used in joining two or more electronic components' terminals and connecting wires on printed circuit board (PCB). The ideal power rating used for this purpose is 30 watts

**Soldering gun**- has a larger power rating, usually 100-140 watts. It is used for soldering work requiring higher temperature like direct chassis soldering. This device is also convenient for intermittent operation, since it heats almost instantaneously when you press the trigger

**Desoldering tool**- used to remove soldering lead when a component is to be removed from the PCB where it is soldered. The soldered joint is heated by a soldering iron or a soldering gun, and then the soldering tool pulls the molten solder out of the connection

**Soldering iron stand**- used to support a heated soldering iron when not in used

**Paint brush**- used in cleaning components mounted on printed circuit boards. It is also used in removing dust inside and outside of electronic apparatus

**Mini-drill** - a tool used for drilling small holes through printed circuit boards (PCB), wood or plastic. It consists of a chuck which is adjustable to handle drill bits from 1/32" to 1/16" diameter. This device is supplied with 12V dc voltage from a battery or from an adapter with 12V dc output

**Screwdriver** – an instrument designed to drive in and take out screws. The two most common types used in the electronic shop are the *standard screwdrivers* with a flat tip, and the *Philip Screwdriver* with the crossed tip to fit the recesses of a Philips-head screw. Both of these types are manufactured in various sizes and styles such as the standard, stubby, and offset. An important rule to remember in the use of screwdrivers is to use the right size for the right screw. Too big a size damages the slot of the screw and may even cause the screw to break. Too small a size will dent the screwdriver and also damage the slot of Philips screws

**Pliers** - designed for gripping the holding small parts in electronic servicing, assembly and troubleshooting

**Side-cutting pliers** - these are used mainly for gripping, bending, cutting small electronic components' terminal or wire. When this pliers is provided with insulated handles, it is also called electrician's pliers

**Long-nosed pliers** - these are manufactured either straight or bent. They are used for holding very small parts and for positioning in hard-to-get-at place. They are also



very useful in making small loops or rings out of wires. This is sometimes called needle-nosed pliers. The bent kind is also known as crooked-nosed pliers

**Diagonal-cutting pliers-** or simply diagonals are useful in cutting excess terminals of components after soldering them in the printed circuit board

**Nipper-type diagonal cutter-** used for precise cutting of components' terminal. This type of pliers is used where accuracy is a factor in cutting the excess leads of components soldered in the printed circuit board

## LEARNING OUTCOME 1

### Maintain hand tools and equipment

## PERFORMANCE STANDARDS

- Tools are used according to undertaken task.
- Routine maintenance of tools undertaken according to standard operational procedures, principles and techniques.
- Tools stored safely in appropriate locations in accordance with manufacturers specifications or standard operating procedures.



## What Do You Already Know?

Let us determine how much you already know about maintaining tools and equipment. Take this test.

Pretest LO 1

**Directions:** Choose the correct answer. Write your answer in a separate sheet of paper.

1. This is safety reminder “prevention is better than \_\_\_\_\_”.  
A. Accident  
B. Cure  
C. Electric shock  
D. Nothing
2. If it cannot be avoided working with “live” wires, you may do the job provided you have to work with:  
A. Both hands  
B. Goggles  
C. One hand  
D. Wet hands
3. If you used a damaged hand tool, what will you do?  
A. Tag a tool  
B. Don't use it  
C. Put in a trash can  
D. None of the above

4. As part of the normal operating and safety procedure, these tools should be returned to the \_\_\_\_\_ after use.
- A. classroom  
B. laboratory  
C. store  
D. tool box
5. When sharpening hand tools, follow normal \_\_\_\_\_ procedure.
1. friendly  
2. common  
C. safety  
D. sanitary



## What Do You Need To Know?

Read Information Sheet 1.1 very well then find out how much you can remember and how much you learned by doing Self-check 1.1.

### Information Sheet 1.1

#### Maintaining Tools

To avoid accidents in the work place due to incorrect use of hand tools, it is a must that you understand the proper use of these tools. Study and practice proper use and maintenance of tools to prolong their life span and of course to avoid accidents due to improper or misuse of such tools.

#### Proper Use, Maintenance, and Storage of Tools

The use of safety hand tools should be a key component of most school safety programs. An understanding of the hand tool's intended use and environment, combined with proper tool selection, maintenance and storage, will greatly reduce the risk of harmful accidents.

**The following are guidelines maintaining and storing tools.**

- Keep hand tools clean and free from ferrous or other contaminants.
- Do not use hand tools in direct contact with acetylene, due to the possible formation of explosive acetyl ides, especially in the presence of moisture.
- During normal use, all pliers and screwdrivers will progressively develop some damage to the striking faces of screwdrivers or the cutting edge and striking end of pliers. As part of the normal operating and safety procedures, these tools should be returned to the workshop, as with steel tools, to have the faces

and heads redressed. This is essential to prevent eye damage resulting from chips detaching from the item during use.

- Do not use hand tools fitted with wooden handles in places where the handles may dry out and shrink. This will increase the risk of the handle breaking or the head becoming loose.
- Tools are designed for specific use. As with any tool. In addition to the probability that the tool will be damaged, this is a dangerous practice for the safety of the operator.
- The accepted standards of safety and maintenance for common steel hand tools must also be adopted with non-sparking hand tools, in addition to any specific recommendations resulting from the alloys used.
- When sharpening hand tools, follow normal safety procedures, such as the provision of eye and face protection, adequate extraction and dust collecting facilities.

Specifically, some tools require special care and maintenance due to their features and frequent use in any electronics or electrical job. Additional care and maintenance must be observed to the following:

➤ **Soldering iron**

- Always clean the tip before and after using.
- Do not wash the tip just to speed up its cooling process after using it. It might damage the heating element and corrode the tip.

➤ **Soldering gun**

- Be sure to tighten the two nuts holding the tip before using it to have maximum heat transfer to its tip.

Soldering gun



- Never use a soldering gun in mass production assembly. It might be overheated and will consume more power compared to a soldering iron.

➤ **Desoldering tool**

- Keep it in good condition by cleaning its inside and apply a small amount of oil regularly.



Desoldering tool

- Avoid direct contact of the soldering iron's tip to the tip of the desoldering tool when doing desoldering work.

➤ **Electric drills**

These are tools that are used to bore holes in metals, wood, plastic or PCB in the process of electronic projects assembly. The most common of these are the mini drill powered from 12V DC voltage and the standard electric drill that can be connected directly to the 220 V AC power line.

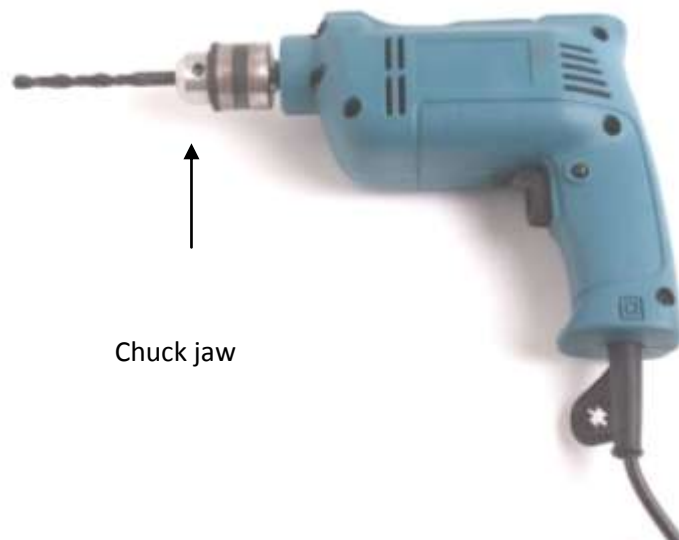

Chuck jaw

Before using a drill, be sure to tighten the chuck jaw and secure the drill bit properly. The materials to be bored and the drill bit must be at 90 degrees angle to achieve efficient boring operation.

For more efficient and quality output with zero accident, the following *Safety Pointers in Electronics Shop work* are additional reminders for you to follow:

As a reminder, a good technician should always remember that “prevention is better than cure” to avoid accidents that might cause damage to tools, instruments, or even inflict injuries to himself while performing electronic jobs.

Accidents can be prevented by following the reminders listed below:

- Be sure you are physically and mentally fit when working with electrical or electronic circuits.
- Use only standard tools and instruments in performing any electronic job.
- Always use the right tool for the right job.
- Do not attempt to use tools or instruments you are not familiar with. Ask the assistance of your teacher or a person in authority in operating such unfamiliar electronic gadget.
- Keep all tools and instruments in a safe place like tool box or tool cabinet to avoid accident and easy access when these tools are needed for use.
- If accidents happened, report immediately to your teacher.
- Keep all tools and instruments in good condition by following the steps of proper care and maintenance of electronic tools and instruments.
- Your working area must be kept clean, in order, and free from any object that might hamper your work.
- Keep flammable substance and materials away from your working area by keeping them in a safe place intended for them.
- If possible, work with only one hand while working in a “live” circuit.
- Keep yourself insulated from earth ground when working on power line circuit, since one side of the line is connected to the earth.
- When your work is done, clean your working table and return all tools and instruments in their proper places.
- Clean tools and equipment work more efficiently. At the end of each working day clean the tools and equipment you used and check them for any damage. If you note damage, *tag the tool* as faulty and organize a repair or replacement.
- Electrical current can travel over oily or greasy surfaces. Keep electrical power hand tools free from dust and dirt and make sure they are free of oil and grease.
  - All workshop hand tools and equipment should have *maintenance schedule*. Always complete the tasks described on the schedule at the required time. This will help to keep the hand tools in safe working order.





## How Do You Apply What You Have Learned?

Show that you learned something by doing this activity

Operation Sheet 1.1

**I. Directions:** Conduct a maintenance activity on the given hand tools with the following guide questions:

1. What will you do if a hand tool is damaged due to misuse?
2. You are working in an untidy work station, what will you do?
3. If the hand tools are oily or greasy, what is the proper thing to do?

Answer the above questions by filling in the matrix below. Do this on a separate answer sheet.

Hand tools	Condition of the hand tools	Action taken to the hand tools
long nose pliers	rusty	
flat screw driver	rounded tip	
soldering iron	distorted tip	
diagonal cutter	dull cutting edges	
paint brush	oily brush	

### II. Instruction:

1. Observe your teacher as he/she demonstrates on how to maintain and store the hand tools properly. You will be grouped into five (5) and to be tested in the procedure in maintaining and storing hand tools.
2. After finishing each laboratory activity, your teacher will grade you.
3. You must get a score of 7-9 to get a grade (Very Good), for this laboratory activity. An assessment criterion will guide your teacher.



### Assessment Criteria

Score	Descriptive Grade
10	Excellent
7-9	Very good
6	Good
3-5	Fair
2-0	Poor

**III. Directions:** Make a matrix indicating the different hand tools grouped according to classification and their uses.

### IV. Procedure in maintaining and storing of hand tools

1. Provide a safety cabinet for all the hand tools and assign a specific area for each tool.
2. It should be cleaned before returning it to the tool rack.
3. Damage hand tools should be repaired.
4. Apply oil on all moving parts if possible.
5. Cover the sharp parts of the tools with a cork when not in use.



## How Well Did You Perform?

**Find out by accomplishing the Scoring Rubric honestly and sincerely.  
Remember it is your learning at stake!**

**Directions:** The teacher will grade each group.

Item No.	Storing Laboratory Tools	Rating										Score	
		1	2	3	4	5	6	7	8	9	10		
1	Driving Tools												
2	Soldering Tools												
3	Splicing Tools												
4	Boring Tools												
5	Cutting Tools												
6	Auxiliary Tools												
Total Score / 6 = Final Rating												_____	

## PERFORMANCE TEST

Learner's Name	Date														
Competency:	Test Attempt 1st    2nd    3 <sup>rd</sup>														
<b>Directions:</b>  CALL TEACHER, ask instructor to assess your performance in the following critical task and performance criteria below  You will be rated based on the overall evaluation on the right side.	<table border="1" style="width: 100%; border-collapse: collapse;"> <tr> <th colspan="2" style="text-align: center; padding: 5px;">OVERALL EVALUATION</th> </tr> <tr> <th style="width: 15%; padding: 5px;">Level Achieved</th> <th style="padding: 5px;">PERFORMANCE LEVELS</th> </tr> <tr> <td style="padding: 5px;"></td> <td style="padding: 5px;">4 - Can perform this skill without supervision and with initiative and adaptability to problem situations.</td> </tr> <tr> <td style="padding: 5px;"></td> <td style="padding: 5px;">3 - Can perform this skill satisfactorily without assistance or supervision.</td> </tr> <tr> <td style="padding: 5px;"></td> <td style="padding: 5px;">2 - Can perform this skill satisfactorily but requires some assistance and/or supervision.</td> </tr> <tr> <td style="padding: 5px;"></td> <td style="padding: 5px;">1 - Can perform parts of this skill satisfactorily, but requires considerable assistance and/or supervision.</td> </tr> <tr> <td colspan="2" style="text-align: center; padding: 5px;">The teacher will initial the level achieved.</td> </tr> </table>	OVERALL EVALUATION		Level Achieved	PERFORMANCE LEVELS		4 - Can perform this skill without supervision and with initiative and adaptability to problem situations.		3 - Can perform this skill satisfactorily without assistance or supervision.		2 - Can perform this skill satisfactorily but requires some assistance and/or supervision.		1 - Can perform parts of this skill satisfactorily, but requires considerable assistance and/or supervision.	The teacher will initial the level achieved.	
OVERALL EVALUATION															
Level Achieved	PERFORMANCE LEVELS														
	4 - Can perform this skill without supervision and with initiative and adaptability to problem situations.														
	3 - Can perform this skill satisfactorily without assistance or supervision.														
	2 - Can perform this skill satisfactorily but requires some assistance and/or supervision.														
	1 - Can perform parts of this skill satisfactorily, but requires considerable assistance and/or supervision.														
The teacher will initial the level achieved.															

PERFORMANCE STANDARDS			
For acceptable achievement, all items should receive a "Yes" or "N/A" response.	Yes	No	N/A
<i>Get from Performance criteria of the module (TR)</i>			

## LEARNING OUTCOME 2

### Perform basic preventive maintenance of electronic tools and equipment

#### PERFORMANCE STANDARDS

- Tools are used according to task undertaken.
- Routine maintenance of tools undertaken according to standard operational procedures, principles and techniques.
- Tools stored safely in appropriate locations in accordance with manufacturers specifications or standard operating procedures.



### What Do You Already Know?

Let us determine how much you already know about performing basic preventive maintenance of electronic tools and equipment. Take this test.

Pretest LO 2

1. The correct use of hand tools is always the key to \_\_\_\_\_.  
A. project construction                      C. lab safety program  
B. components soldering                      D. environmental compliance
2. Keep hand tools clean and free from \_\_\_\_\_.  
A. dust    C. machine oil  
B. contaminants                                      D. moisture
3. Which soldering tool is used for high temperature soldering?  
A. Soldering pencil                              C. Soldering gun  
B. Soldering iron                                      D. Hot air
4. What equipment need to be tested once a week?  
A. DMM    C. Oscilloscope  
B. Frequency meter                                      D. VOM
5. What tool is used to remove solder from the PCB?  
A. Hot air    C. Soldering pencil  
B. Soldering gun                                      D. Desoldering tooi



## What Do You Need To Know?

Read Information Sheet 2.1 very well then find out how much you can remember and how much you learned by doing Self-check 2.1.

### Information Sheet 2.1

## Maintaining Hand tools

### 1. Screwdrivers

- A. Select a screwdriver that fits the screw head slot perfectly.
- B. Keep the screwdriver's handle dry, and clean to prevent slippages.
- C. Never use a screwdriver as chisel.
- D. Never hammer a screwdriver's handle.

### 2. Pliers

- A. Always keep pliers in good condition by cleaning and regular application of oil.
- B. Never use pliers as substitute for a wrench or hammer.
- C. Never hammer the pliers when cutting wires.

### 3. Files

- A. When using a file, keep a firm grip on its handle at all times.
- B. Do not blow filings as they may get into your eyes .
- C. Always use a file card in cleaning a file.

### 4. Mini drill

- A. Hold the mini drill firmly at 90 degrees with the material to be bored and make sure to tighten the chuck jaw of the mini drill securely before using it.
- B. Hold the metal, wood, or plastic firmly on the vise when drilling holes. Do not hold it with your hands.
- C. Clean chips with a brush, not with your hands.
- D. Keep the work area always clean by using paint brush.

### 5. Pencil type soldering Iron.

- A. Clean and maintain the tip of the soldering iron before use.
- B. A 30-watt soldering iron is recommended for soldering electronic components in printed circuit board.
- C. Clean the soldering tip with dry cloth, cotton, or tissue paper after using.
- D. Do not wash the tip of the soldering iron with water to speed up its cooling process after use It might corrode the soldering tip.

6. **Soldering Gun**
  - A. Do not use this type of the soldering instrument with light soldering work. It might damage the Electronic components and PCB because of its very high temperature.
  - B. If the soldering tip fails to achieve its maximum temperature, tighten the two nuts holding the tip of the soldering gun.
  - C. Do not use in mass production assembly. It might be overheated.
  - D. This type of soldering equipment is more convenient where only few connections are to be made requiring much higher temperature like direct chassis soldering.
  
7. **Desoldering tool**
  - A. Heat the terminals to be resoldered before sucking the melted soldering lead with the desoldering tool to avoid direct contact of the desoldering tool's tip with the tip of the soldering iron.
  - B. Clean and oil the inside sucking spring and the tip of the desoldering tool regularly so that the melted soldering lead will not stick permanently inside the desoldering tool.
  
8. **Volt -Ohm- Milliammeter ( VOM)**
  - A. Do not play with this instrument by holding both test leads or connecting them in any part of your body trying to measure your resistance .
  - B. Rest the function switch at 250 VAC when not in use.
  - C. Place this instrument in a dry cool place, In free from any vibrations
  - D. When making current and voltage measurements, be sure you are in the correct settings of function switch .If the current or voltage being measured is much greater than the value indicated in the function switch, the VOM will be damaged.
  - E. Avoid touching any metallic part of the test lead when measuring current or voltage
  
9. Electronic instruments like oscilloscopes, signal generators, digital multimeters and like should be connected to the power line at least once a week to warm up the circuit. This will serve as regular check-up and it will prevent the electronic components from corrosion due to moist specially during rainy season when the air is wet.



## How Much Have You Learned?

### Self-Check 2.1

1. What tool is used to remove solder from the PCB?  
A. Hot air  
B. Soldering gun  
C. Soldering pencil  
D. Desoldering tool
2. Keep hand tools clean and free from\_\_\_\_\_.  
A. dust  
B. contaminants  
C. machine oil  
D. moisture
3. Which soldering tool is used for high temperature soldering?  
A. Soldering pencil  
B. Soldering iron  
C. Soldering gun  
D. Hot air
4. What equipment needs to be tested once a week?  
A. DMM  
B. Frequency meter  
C. Oscilloscope  
D. VOM
5. The correct use of hand tools is always the key to \_\_\_\_\_.  
A. project construction  
B. components soldering  
C. lab safety program  
D. environmental compliance

**Refer to the Answer Key. What is your score?**



**Congratulations! You did a great job! Rest and relax a while then move on to the next lesson. Good luck!**

## REFERENCES

- Enriquez, Marcelo T. Electronics Technology IV; Souvenir Publications, Inc.: 2003
- L Tan, Michael Q., Gantalao, Fred T., Lasala, Rommel M. Simple Electronics; Andes Mountain Printers: 2004



## Answer Keys:

### Lesson 1. Use Hand Tools

#### LO1 Self-Check 1.1

Hand tools	Classification
1. Desoldering Tool	Soldering tool
2. Wire Splicer	Splicing tool
3. Side Cutter	Splicing tool
4. Long Nose Pliers	Splicing tool
5. Mini Drill	Boring tool
6. Magnifying Glass	Auxiliary tool
7. Soldering Stand	Soldering tool
8. Screwdriver	Driving tool
9. Soldering Iron	Soldering tool
10. Portable Electric Drill	Boring tool

#### Self Check 1.2

1. It is suitable for electronic work because if we exceed its maximum temperature, it can cause the printed circuit board to break and result to damage of components.
2. It is the best because it is flexible in observing all sides of the circuit guided by bright light.
3. It is best to use the right size of the Philips screw driver because this will prevent the screw from loosen its thread.
4. It is best to use the right size of drill bit in boring holes because undersized drilled holes will need to be drilled again (This will prolong the work activity) while oversized holes will cause a wastage in the material.
5. Soldering stand keeps the soldering iron from flammable materials and protects the user from accidentally touching the hot portion of the soldering iron.

#### LO2. Use Appropriate Hand tools and Test equipment

##### Self Check 2.1

1. C (wire stripper)
2. D (mini drill)
3. A (screw driver)
4. E (desoldering tool)
5. B (long nose pliers)
6. G (hacksaw)
7. F (paint brush)
8. I (magnifying glass)

## Lesson 2 Perform Mensuration and Calculation

### LO 1. Select Measuring Instrument

#### Self Check 1.1

1. C (50K ohms +/- 5%)
2. A (gold)
3. B (green)
4. C (resistor)
5. A (current)

### LO 2. Carry out measurements and calculation

#### Self Check 2.1

1. A (90 ohms)
2. B (242 ohms)
3. C (22)
4. B (.05)
5. D (tolerance)

#### Self Check 2.2

1. B (Ohmmeter)
2. B (Reading Scale)
3. A (R X 1)
4. C (Nonlinear)
5. D (VOM)

### LO 3. Maintaining Measuring Instruments





#### Self Check 3.1

1. D (VOM)
2. D (Signal Generator)
3. D (250AC)
4. C (Magnetic Devices)
5. C (Oscilloscope)





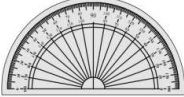











## Lesson 3. Identifying different kinds of drawings

### LO 1. Identify different kinds of Technical Drawings

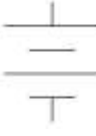
#### Self check 1.1

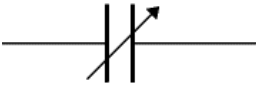
Drawing instrument	Description	Use
ELECTRONIC TEMPLATE 	A thin flexible plastic with different electronic and electrical symbols.	The symbols can be traced using a technical pen or pencil in laying out schematic diagrams.
COMPASS 	The compass has two legs hinged at one end. One of the legs has pointed needle fitted at the lower end where as the other end has provision for inserting pencil lead.	A compass is used for drawing circles and arcs of circles.
DRAWING PINS 	These are usually made of pointed metal and plastic head with different colors.	These are used to fix the drawing sheet on the drawing board.
PROTRACTOR 	They are semicircular in shape and are made of plastic.	Protractors are used to mark or measure angles between 0 and 180°.
T-SQUARE 	It consists of two parts namely the stock and the blade joined together at right angles to each other by means of screws.	The working edge of a T-square is used to draw parallel lines, vertical lines or inclined lines at 30 or 60 degrees.

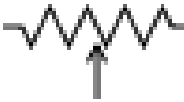
### Self Check 1.2

Type / Symbol	Actual / Physical appearance	Uses / Application
 <p>1. NPN transistor</p>		<p>A bipolar junction transistor (BJT) with P-type base electrode. This device is used to amplify signal.</p>
 <p>2. Zener diode</p>		<p>It is a semiconductor diode that is used as voltage regulator for low current application.</p>
 <p>3. Polarized capacitor</p>		<p>Stores electric charge and used as filter to separate ac from dc voltage. Always take note of proper polarity when connected to a circuit.</p>
 <p>4. Light-Emitting Diode (LED)</p>		<p>A semiconductor diode that emits light when supplied with forward voltage. They come in different colors like red, green, yellow, or blue.</p>
 <p>5. PNP transistor</p>		<p>A bipolar junction transistor (BJT) with N-type base electrode. This device is used to amplify signal.</p>
 <p>6. Battery</p>		<p>A dc voltage storage device that are used in electronic toys, equipment, or appliance.</p>
 <p>7. Variable capacitor</p>		<p>These are usually non-polar capacitors that are used in tuning radio receivers and other electronic communication system. Their capacitance varies as you turn their shaft either clockwise or counterclockwise.</p>
 <p>8. Potentiometer</p>		<p>It is a variable resistor with three terminals used as volume, tone, or balance controls of audio equipment.</p>

## **LO 2. Interpret Technical Drawings**

### **Self Check 2.1**

1. Schematic diagram
2. Wiring diagram
3. Block diagram
4. Pictorial diagram
5. Schematic diagram

## **LO 3. Prepare electronic diagrams**

### **Self Check 3.1**

1. A (Q)
2. B (Dashed lines)
3. A (Bracket)
4. D (Symbols)
5. C (Ohms)

# **Lesson 4 Practice Occupational Health and Safety**

## **LO 1. Identify health hazards and occupational risks**

### **Self Check 1.1**

1. Avoid bending over your work
2. Avoid over head work
3. Sit up straight
4. Stand with weight evenly distributed on both legs
5. Torque control

## **LO 2. Observe occupational health and safety practices**

### **Self Check 2.1**

1. True
2. Always
3. True
4. Can engage
5. True

# **Lesson 5 Maintain Tools and Equipment**

## **LO 1. Maintain tools and equipment**

### **Self Check 1.1**

1. C (safety)
2. D (tool box)
3. A (Tag a tool)
4. C (One hand)
5. B (Cure)

**LO 2. Perform basic preventive maintenance of electronic tools and equipment**

**Self Check 2.1**

1. **D (Desoldering tool)**
2. **B (Contaminants)**
3. **C (Soldering gun)**
4. **C (Oscilloscope)**
5. **C (Lab safety program)**

**PRE – TEST  
Answer keys**

**LESSON 1.**

**LO 1.**

1. **L**
2. **I**
3. **H**
4. **F**
5. **D**
6. **A**
7. **C**
8. **E**
9. **K**
10. **B**

**LO2.**

1. **A**
2. **A**
3. **B**
4. **D**
5. **B**

**LESSON 2**

**LO1.**

1. **C**
2. **B**
3. **B**
4. **D**
5. **D**

**LO2.**

1. **D**
2. **B**
3. **C**
4. **B**
5. **A**

**LO3.**

1. D
2. D
3. D
4. C
5. C

**LESSON 3**

**LO1.**

1. C
2. A
3. D
4. A
5. B

**LO1.2**

1. E
2. F
3. A
4. B
5. C

**LO2**

1. A
2. B
3. B
4. A
5. D

**LO3**

1. D
2. B
3. A
4. C
5. D

**LESSON 4**

**LO1**

1. C
2. D
3. A
4. C
5. C

**LO2**

1. True
2. Always
3. True
4. Can engage
5. True

**LESSON 5**

**LO1.**

1. B
2. C

LO2

3. A
4. D
5. C
  
1. C
2. B
3. C
4. C
5. D



## *Acknowledgement*

This Learning Module was developed for the Exploratory Courses in Technology and Livelihood Education, Grades 7 and 8 of the K to 12 Curriculum with the assistance of the following persons:

This Learning Module on **Consumer Electronics Servicing NC II** was developed by the following personnel:

### **MODULE WRITERS**

**MARCELO E. TAN, Ed. D.**  
*EPS 1, DepED-Manila*

**REYNALDO C. CUNANAN**  
*Head Teacher VI, RVHS*

### **REVIEWERS**

**GIL P. CASUGA**  
*Chief TESD Specialist*

**REYNALDO S. DANTES**  
*Senior TESD Specialist*

**BERNADETTE S. AUDIJE**  
*Senior TESD Specialist*

**MARIA A. ROQUE**  
*Senior TESD Specialist*

**AIDA T. GALURA**  
*VSA II, ACNTS*

**VICTORIO N. MEDRANO**  
*Principal IV, SPRCNHS*

**PARALUMAN R. GIRON, Ed.D.**  
*Chair, Sub-TWG on K to 10*

**BRENDA B. CORPUZ, Ph.D.**  
*TA for K to 12 Curriculum*

**OFELIA O. FLOJO**  
*Retired Assistant Chief, EED, Region IV-A*

**OFELIA O. FLOJO**  
*Retired Assistant Chief, EED, Region IV-A*

**BEATRIZ A. ADRIANO**  
*Principal IV, ERVHS*

**DOMINGA CAROLINA F. CHAVEZ**  
*Principal II, MBHS*

### **DOCUMENTORS / SECRETARIAT**

**PRISCILLA E. ONG**  
*K to 12 Secretariat*

**FREDERICK G. DEL ROSARIO**  
*Head Teacher III, BNAHS*

**EMMANUEL V. DIONISIO**  
*Head Teacher III, AFGBMTS*

**LYMWEL P. LOPEZ**  
*Teacher I, AFGBMTS*

**DANTE D. VERMON JR.**  
*Teacher I, AFGBMTS*

**ROMANO T. LOPEZ JR.**  
*Teacher I, AFGBMTS*

**JOANNA LISA C. CARPIO**  
*Teacher I, BNAHS*

**LOUIE ANGELES**  
*Teacher I, BNAHS*

**Dir. IMELDA B. TAGANAS**

*Executive Director, Qualifications Standards Office  
K to 12 Learning Area Team Convenor, TLE/TVE*