

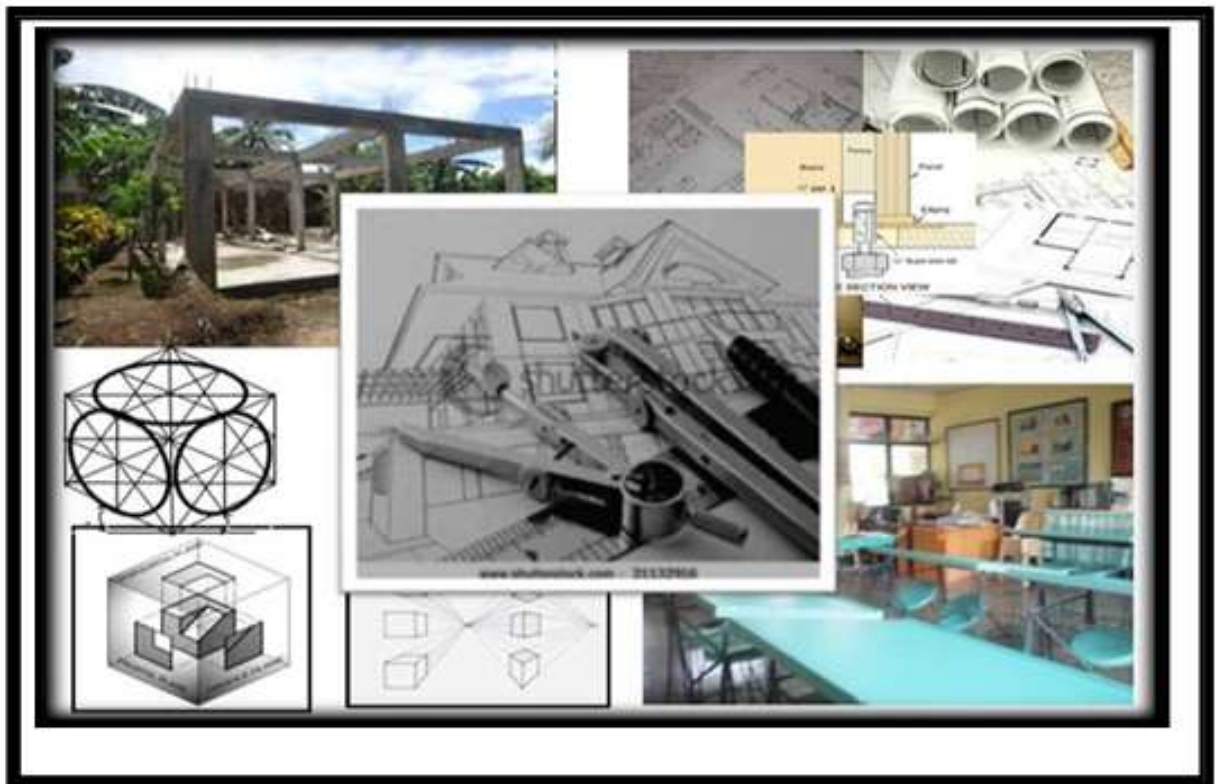

Republic of the Philippines
DEPARTMENT OF EDUCATION



K to 12 Basic Education Curriculum Technology and Livelihood Education Learning Module



MECHANICAL DRAFTING

EXPLORATORY COURSE

Grade 7 and Grade 8

TABLE OF CONTENTS

	Page
What Is This Module About?	2
How Do You Use This Module	3
LESSON 1 - Prepare Drafting Materials and Tools/Drawing Instrument 4	
LESSON 2 - Perform Basic Mensuration and Calculation	30
LESSON 3 - Interpret Working Plans and Sketches	67
LESSON 4 - Apply Safety Practices	131
Answer Keys	166
List of Materials /Tools/Equipment /Consumables for this Module	177
Acknowledgment	178



What Is This Module?

Welcome to the world of **MECHANICAL DRAFTING!**

This Module is an exploratory course which leads you to **Mechanical Drafting National Certificate Level II (NC II)**¹. It covers the **4** common competencies that a Grade 7 / Grade 8 Technology and Livelihood Education (TLE) student like you ought to possess, namely:

1. Prepare Drafting Materials and Tools/Drawing Instruments
2. Perform Basic Mensuration and Calculation
3. Interpret Working Plans and Sketches
4. Apply Safety Practices

These **4** common competencies are covered separately in 4 Lessons. As shown below, each Lesson is directed to the attainment of two or more learning outcomes:

Lesson 1 - **Prepare Drafting Materials and Tools/Drawing Instruments**

- LO 1. Identify drafting materials and tools/drawing instruments applicable to a specific job
- LO 2. Request, receive and inspect drafting materials and tools/drawing instruments

Lesson 2 - **Perform Basic Mensuration and Calculation**

- LO 1. Select and use measuring instruments
- LO 2. Clean and store measuring instruments
- LO 3. Convert fraction to decimal and vice versa
- LO 4. Convert English to Metric Measurement vice versa

Lesson 3 - **Interpret Working Plans and Sketches**

- LO 1. Identify assembly and detailed drawing.

Lesson 4 - **Apply Safety Practices**

- LO 1. Identify hazardous area
- LO 2. Use personal protective clothing and devices

Your success in this exploratory course on **Mechanical Drafting** is shown in your ability to perform the performance standards found in each Lesson .

¹**NATIONAL CERTIFICATE (NC)** is a certification issued to individuals who achieved all the required units of competency for a national qualification as defined under the Training Regulations. NCs are aligned to specific levels within the PTQF. (TESDA Board Resolution No. 2004-13, Training Regulations Framework)

NATIONAL CERTIFICATE LEVEL refers to the four (4) qualification levels defined in the Philippine TVET Qualifications Framework (PTQF) where the worker with:

a. **NC I** performs a routine and predictable tasks; has little judgment; and, works under supervision;

b. **NC II** performs prescribed range of functions involving known routines and procedures; has limited choice and complexity of functions, and has little accountability;



How Do You Use This Module?

This Module has 4 Lessons. Each Lesson has the following parts.

- Learning Outcomes
- Performance Standards
- Materials
- Definition of Terms
- What Do You Already Know?
- What Do You Need to Know?
- How Much Have You Learned?
- How Do You Apply What You Learned?
- How Well Did You Perform?
- How Do You Extend Your Learning?
- References

To get the most from this Module, you need to do the following:

1. Begin by reading and understanding the Learning Outcome/s and Performance Standards. These tell you what you should know and be able to do at the end of this Module.
2. Find out what you already know by taking the Pretest then check your answer against the Answer Key. If you get 99 to 100% of the items correctly, you may proceed to the next Lesson. This means that you do not need to go through the Lesson because you already know what it is about. If you failed to get 99 to 100% correctly, go through the Lesson again and review especially those items which you failed to get.
3. Do the required Learning Activities. They begin with one or more Information Sheets. An Information Sheet contains important notes or basic information that you need to know. After reading the Information Sheet, test yourself on how much you learned by answering the Self-check. Refer to the Answer Key for correction. Do not hesitate to go back to the Information Sheet when you do not get all test items correctly. This will ensure your mastery of basic information.
4. Demonstrate what you have learned by doing what the Activity / Operation /Job Sheet directs you to do.
5. You must be able to apply what you have learned in another activity or in real life situation.
6. Accomplish the Scoring Rubrics for you to know how well you performed.

Each Lesson also provides you with references and definition of key terms for your guide. They can be of great help. Use them fully.



If you have questions, ask your teacher for assistance.

LESSON 1

Prepare Drafting Materials and Tools/Drawing Instrument



LEARNING OUTCOMES:

At the end of this Lesson, you are expected to do the following:

- LO 1. identify the different drafting materials and tools/drawing instruments applicable to a specific job
- LO 2. request, receive and inspect drafting materials and tools/drawing instruments



Definition of Terms

Assembly drawing - a drawing that shows how different parts of an object go together

Compass - an instrument used when drawing arcs and circles

Delivery receipt - a form that shows proof or receipt of goods or services

Detailed drawing - a drawing showing a single part of a machine

Dimensioning - the process of placing measurements in a drawing in the Metric or English system

Divider - a drawing instrument used when transferring measurements, dividing lines, arcs into the desired number of equal parts

Drawing - a picture, diagram made of lines, a graphic representation of real thing, an idea or a design for production or construction

Drawing pencil - one of the most important tools of a draftsman, a tool used for drawing

English system - a system of linear measurement where it is based on standard foot

Erasing shield - used when clearing up smudges, unnecessary pencil lines

Geometrical construction - the process wherein geometric problems are solved accurately in mechanical drawings

Mechanical drafting - a process for making accurate drawings using special drawing tools and instruments

Metric system - a system of linear measurement which it is based on the standard meter

Orthographic drawing - the object is presented into two or more views by projecting the outline into the planes of projection perpendicular to each other

Pictorial view - the presentation of an object where it is viewed showing the three faces of an object are shown

Protractor - used for determining gradations of the degrees when measuring arcs and circles

Requisition form - an official form, a printed document on which a request is made

Sketch - a quickly executed freehand drawing that is not intended as a finished work

Triangular scale - a tool generally used when reproducing a drawing in an enlarged or reduced version to some regular proportion

T-Square - a drawing instrument used when drawing horizontal and vertical lines

Acronyms

EDP System - Electronic Data Processing System

LEARNING OUTCOME 1

Identify drafting materials and tools/drawing instruments applicable to a specific job.

PERFORMANCE STANDARDS

1. Drafting materials and tools/drawing instruments are identified per job requirements.
2. Materials and tools/drawing instruments are classified according to their uses to a specific drafting project.



Materials

- T- square
- Triangles 30 x 60 and 45 x 45
- Pencils/ mechanical pencils
- Compass/ Divider
- Drawing paper
- Drawing board
- Triangular Scale
- Eraser
- Erasing shield
- Protractor
- Sharpener
- Drawing Tape



What Do You Already Know?

Let us determine how much you already know about drafting materials and tools/drawing instruments. Take this test.

Pretest LO 1

Direction: Select the drafting material and tool/drawing most applicable to a specific job.

1. A drafting tool used for drawing horizontal lines
A. Compass B. Triangle C. T- square D. Triangular Scales
2. Drafting material used for fastening the drawing paper on the drawing table
A. Compass B. Divider C. Masking Tape D. Triangle
3. The main function of this tool is to reproduce the measurements of an object to any size.
A. Compass B. Protractor C. Triangle D. Triangular Scales
4. This drafting tool is used to protect the rest of the drawing when removing unnecessary lines.
A. Erasing Shield B. Eraser C. Masking Tape D. Pencil Sharpener
5. This drafting tool is used when drawing vertical lines.
A. Compass B. Triangle C. Triangular Scales D. Ruler

Direction: Match Column A with Column B. Write only the letter of the correct answer on a separate sheet of paper.

Column A

1. Type of pencils when extreme accuracy is required
2. Used to clean the dirt off the drawing
3. An instrument used for transferring measurements
4. Type of pencils used for general purpose in drawing
5. Best tool when measuring arcs, angles and circles

Column B

- A. Eraser
- B. Medium pencils
- C. Protractor
- D. Divider
- E. Hard pencils
- F. Triangle

Now check your answers using the Answer Key. If you got 90-100% of the items correctly, proceed to the next Learning Outcome. If not, do the next activity/ties again to gain knowledge and skills required for mastery.





What Do You Need To Know?





Read Information Sheet 1.1 very well then find out how much you can remember and how much you learned by doing Self-check 1.1.



Information Sheet 1.1

DRAFTING MATERIALS AND TOOLS, ITS USES/FUNCTIONS

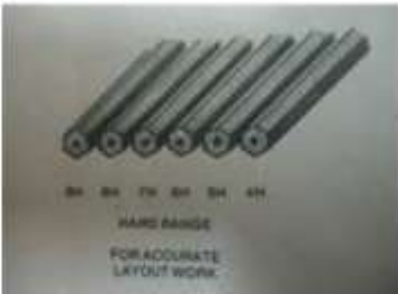
There is a great variety of drafting materials and tools used in mechanical drawing. The drafting materials and tools discussed in this Module include most of the basic ones but sufficient enough for your initial understanding about mechanical drawing.

PICTURES/ILLUSTRATIONS	MATERIALS,DESCRIPTION AND FUNCTION
 <p data-bbox="237 1435 430 1469">Drawing paper</p>	<p data-bbox="592 1189 799 1223"><u>Drawing paper</u></p> <p data-bbox="592 1256 1348 1442">Various types of drawing papers are available for use but hard and soft surface drawing papers are highly recommended. This type does not groove easily when pressure is applied to the pencil. Oslo paper is commonly used but bond paper is also recommended.</p>
 <p data-bbox="237 1823 424 1856">Masking Tape</p>	<p data-bbox="592 1610 783 1644"><u>Masking tape</u></p> <p data-bbox="592 1677 1348 1823">This is used for fastening the drawing paper on the drawing table or drawing board because it does not damage the board and it will not damage the paper if it is removed by pulling it off.</p>





 <p>Pencil sharpener</p>	<p><u>Pencil sharpener</u></p> <p>Pencils should be sharpened whenever they show sign of dullness. Various types and designs are available in the store for use.</p>
 <p>Eraser</p>	<p><u>Eraser</u></p> <p>This is used to clean the dirt off the drawing. A soft eraser is advantageous in removing smudges and pencil marks, whereas, a harder eraser is useful for making changes and correcting errors in the drawing.</p>
 <p>Hard Range</p>  <p>Medium Range</p>  <p>Soft Range</p>	<p><u>Drawing pencil</u></p> <p>This is one of the most important tools in drawing. It comes in various grades. The grade of pencil to be used depends on the quality of paper to be used. You have to take into consideration also the type of line work required.</p> <p>Hard pencils - are used where extreme accuracy is required especially working on graphs, diagrams and charts.</p> <p>Medium pencils - are used for general purpose work in drawing.</p> <p>Soft pencils - are too soft to be used in mechanical drafting. They are very useful for art work of various kinds.</p>

 <p>Triangular Scales</p>	<p><u>Triangular Scales</u></p> <p>This is a tool generally used when reproducing a drawing in an enlarged or reduced form to some regular proportion. The architect's scale is the most commonly used for general drawing. Its main function is to reproduce the measurements of an object in full size, reduced size, and enlarged size.</p>
 <p>Erasing Shield</p>	<p><u>Erasing Shield</u></p> <p>This tool is made up of metal with irregular holes. It is a useful tool to protect the rest of the drawing when clearing up smudges, unnecessary pencil lines and other erasures.</p>

DRAWING INSTRUMENTS

Drawing instruments are used for drawing and designing purposes. Their quality is very essential if you want to have good result. Cheaper drawing tools and instruments do not only provide poor quality results but also do not last long. You have to observe proper handling and care of drawing instrument if you want them to function accurately.

PICTURES/ILLUSTRATIONS	MATERIALS AND TOOLS DESCRIPTION
	<p style="text-align: center;"><u>T-Square</u></p> <p>It is a drawing instrument used when making horizontal lines. It is also used for guiding triangles when drawing vertical lines. It is made of wood, plastic or the combination of both. There are three (3) types of T-square, namely:</p> <ol style="list-style-type: none"> 1. Fixed Head. The head is fastened to the blade. It is used for ordinary work. 2. Movable Head or Adjustable Head. It has one fixed and one adjustable head and used only for occasional drawing. 3. Detachable Head or Removable Head. It is designed for comfort when carrying the T-square.

	<p style="text-align: center;"><u>Triangle</u></p> <p>It is a three-sided ruler, which typically has two equal sides meeting at a 90 degree angle and to a third side at 45, 30, including 60 degree angles. It is usually made of plastic and comes in different sizes. If in use, the base of the triangle must rest on the blade of the T-square. Drawing a line always starts from the point near the base going upward. Commonly used triangles are:</p> <ol style="list-style-type: none"> a. 30 degrees X 60 degrees b. 45 degrees X 45 degrees
	<p style="text-align: center;"><u>Compass</u></p> <p>This drawing instrument is used when drawing arcs and circles. It is used in a similar way to a divider. It is composed of one with the pen leg and the needle point leg being held together with a handle. This drawing instrument can be used for both penciling and inking.</p>
	<p style="text-align: center;"><u>Divider</u></p> <p>This is a drawing instrument used when transferring measurements, dividing lines and arcs into the desired number of equal parts. It can easily transfer accurate measurements by adjusting the divider points. Constant correct practice is necessary before doing an actual work for a quick and easy control when use.</p>
 <p style="text-align: center;">Protractor</p>	<p style="text-align: center;"><u>Protractor</u></p> <p>It is a semi-circular instrument divided into 180 equal parts, each of which is called a degree. It is used to determine gradations of the degrees when measuring arcs, angles and circles. High quality protractor is usually made of plastic.</p>

Did you enjoy reading the given information? Which among the drafting materials, and drawing tools and instruments matter to you most? Well, you are just starting how. Let's move ahead to enrich your understanding.

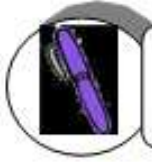

How Much Have You Learned?

Self-Check 1.1

Directions: There are twelve (12) different drafting materials and tools and drawing instruments that can be found in the puzzle. Identify at least ten (10) of them.

A	R	C	Z	I	B	O	K	R	E	N	E	P	R	A	H	S	L	I	C	N	E	P	I	E
B	M	L	U	X	R	D	A	B	Q	L	V	O	S	N	E	O	X	A	C	L	B	E	T	B
C	O	A	F	T	E	R	B	I	A	E	U	N	A	I	R	S	A	O	Q	R	F	P	N	X
D	E	S	S	A	N	A	A	B	U	L	N	K	D	T	S	A	M	D	L	J	J	H	D	D
E	K	I	H	K	T	W	I	E	L	E	A	A	A	O	V	P	P	G	H	Z	Y	S	I	T
F	T	O	A	V	I	A	T	K	I	D	R	S	T	E	A	I	N	X	F	E	X	A	L	R
G	I	R	L	I	S	N	O	A	T	N	Y	A	O	S	R	H	N	S	A	H	E	O	Y	I
H	A	K	X	Y	J	G	G	S	E	L	A	C	S	C	I	R	T	E	M	L	A	C	S	O
I	R	O	G	K	U	P	J	T	V	O	S	B	Q	E	P	E	I	B	Y	A	E	I	O	L
J	O	V	R	O	K	A	R	A	A	Z	X	L	E	N	R	K	Q	O	E	L	D	X	S	E
K	T	I	Z	S	N	P	A	R	E	P	U	T	O	B	X	L	Y	K	S	D	F	E	G	R
L	C	K	A	L	T	E	C	N	T	Y	E	J	X	P	S	E	C	I	L	H	A	T	V	B
M	A	Q	D	I	O	R	B	U	A	K	F	E	O	E	Q	V	C	E	H	R	F	U	S	E
N	R	I	T	C	N	C	X	O	P	E	A	N	V	T	U	A	I	K	A	P	I	T	O	Y
O	T	D	D	N	Y	D	X	R	K	T	O	B	P	E	A	H	U	G	E	A	P	I	P	I
P	O	N	R	E	R	I	Z	N	U	R	N	Q	I	N	S	L	H	O	T	N	D	T	A	R
Q	R	V	X	P	A	Q	S	W	T	R	I	A	N	G	L	E	S	R	R	L	U	E	R	O
R	P	K	G	G	R	A	T	C	T	A	R	P	N	H	A	N	C	E	S	L	C	Q	E	W
S	A	G	D	N	G	L	A	T	O	T	P	I	D	O	L	K	A	D	A	G	S	T	S	K
T	L	J	O	I	O	N	N	X	I	W	S	T	A	K	A	L	B	I	T	B	Z	O	R	F
U	I	V	Y	W	N	A	O	P	L	A	K	Q	I	S	E	B	Y	V	N	A	X	G	U	C
V	T	F	F	A	S	J	Z	I	R	I	C	Y	U	L	M	Z	K	I	R	J	T	E	M	H
W	S	L	B	R	U	V	S	E	Q	D	L	B	J	A	N	T	F	D	O	K	P	L	X	A
X	E	J	A	D	I	E	U	W	A	P	I	E	A	K	R	W	O	E	B	E	O	S	A	E
Y	G	E	H	A	K	G	L	O	T	E	D	S	M	Q	A	E	R	P	V	S	E	I	N	G

Refer to the Answer Key. What is your score?



How Do You Apply What You Have Learned?

It is not enough that you learned concepts on drafting materials and drawing instruments. Be sure that you are also able to demonstrate the skills. Follow the instruction on activity sheet.

Activity Sheet 1.1

Proper Manipulation of the T-square

Directions: Below is a simple activity for you to work on. Practice the task following the given procedure.

Instrument:

- T - Square

Equipment:

- Drawing Table (Drafting Table or Drawing Board)

Procedure:

1. Place the head of the T-square against the edge of the drafting table. (Left side of the table if you are right handed and at the right side of the table if you are left handed).
2. Slide the working head of the T-square against the working edge of the drawing table. The two edges should be in constant contact until the desired position.

Note: Do not use the T-square on an uneven or rough surfaces and never cut paper along its working edge.

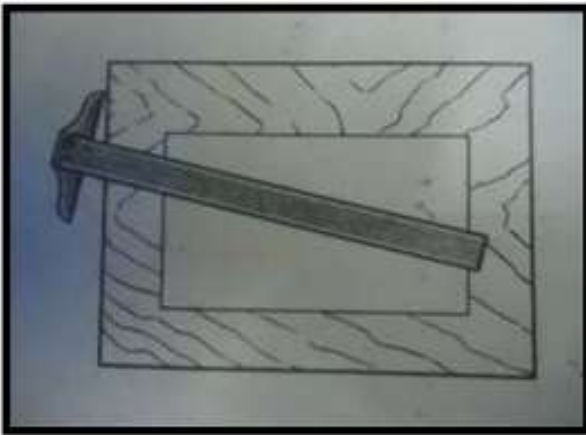

For Right-handed

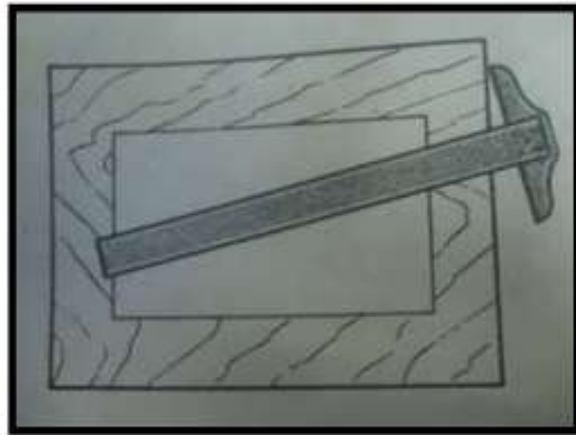

For Left-handed

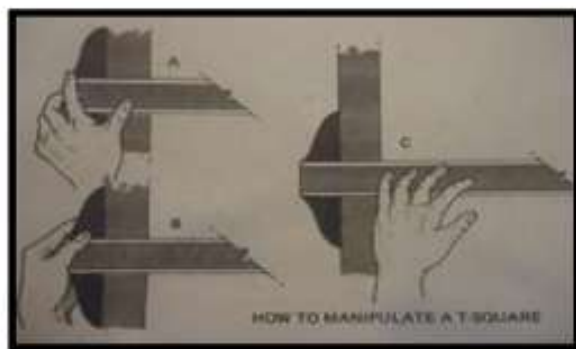

Proper use of T-Square

Setting up Drawing Paper on the Drawing Table

Directions: Below is a simple activity for you to work on. Practice the task following the given procedure.

Materials:

- Drawing paper
- Masking tape

Instrument:

- T - Square

Equipment:

- Drawing Table

Procedure:

1. Press firmly the T-square against the working edge of the drawing table.
2. Place the drawing paper close to the working edge of the drawing table and working head of the T-square depending on you if you are right or left-handed, while the paper is placed on top edge of the T-square.
3. Fasten the upper left portion of the drawing paper followed by the lower right portion and finally the remaining corners.

Note: Always fasten larger backing sheet of thicker drawing paper on the board first.

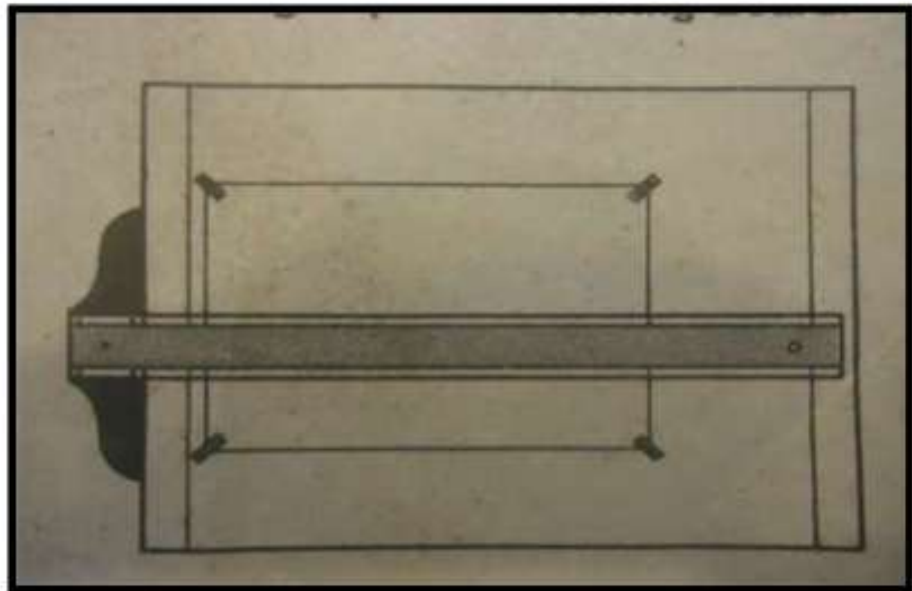

Placing drawing paper to the drawing board

Drawing a Horizontal Line

Directions: Below is a simple activity for you to work on. Practice the task following the given procedure.

Materials:

- Drawing paper
- Masking tape

Instrument:

- T - Square
- Triangles (30 deg. x 60 deg. and 45 deg. x 45 deg.)

Equipment:

- Drawing Table

Procedure:

1. Press the head of the T-square against the working edge of the drawing table and lean the pencil to the desired direction of the line inclined at more or less 60 degrees with the drawing table.
2. Maintain the position of the pencil while you glide lightly on the blade of the T-square.
3. Draw the line from left to right rotating occasionally to produce uniform line weights.

(Reverse this step if you are left-handed).

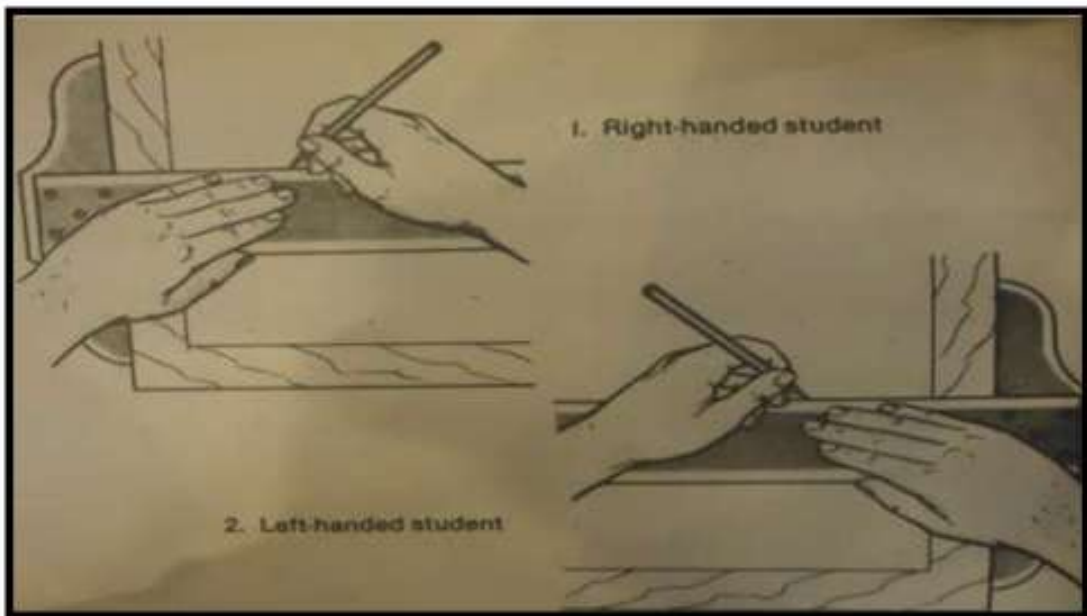

Using the T-Square to draw Horizontal lines

Drawing a Vertical Line

Directions: Below is a simple activity for you to work on. Practice the task following the given procedure.

Materials:

- Drawing paper
- Masking tape

Instrument:

- T - Square
- Triangles (30 deg. x 60 deg. and 45 deg. x 45 deg.)

Equipment:

- Drawing Table

Procedure:

1. Use 45 degrees triangle or 30 degrees x 60 degrees to draw vertical lines.
2. Place the triangle on top of the blade of the T-square with the vertical edge on the left.
3. With the left hand pressing the T-square and the triangle against the drawing board, draw the line upward, rotating the pencil slowly between the thumb and forefinger.

See figure below.

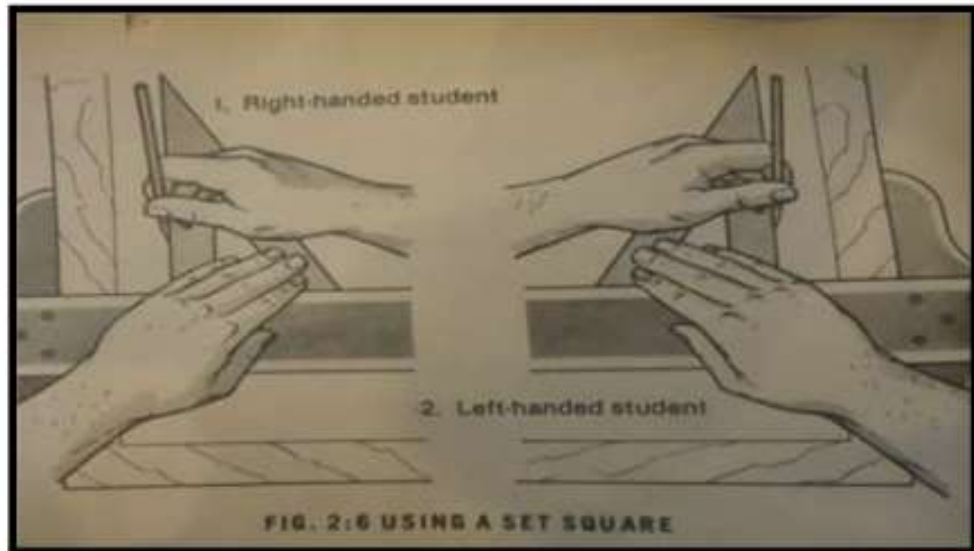

Drawing vertical lines using triangles and T-square

How did you find the activities? Did you enjoy doing them? Did you find them difficult? Challenge yourself by keeping on practicing correctly the given steps in each activity. Have fun!



How Well Did You Perform?

**Find out by accomplishing the Scoring Rubric honestly and sincerely.
Remember it is your learning at stake!**

Learner's Name:		Date:		
Competency:		Test Attempt		
		1st	2nd	3 rd
		<input type="checkbox"/>	<input type="checkbox"/>	<input type="checkbox"/>
<p>Directions:</p> <p>Ask your teacher to assess your performance in the following critical task and performance criteria below</p> <p>You will be rated based on the overall evaluation on the right side.</p>	OVERALL EVALUATION			
	Level Achieved	PERFORMANCE LEVELS		
		4 - Can perform this skill without supervision and with initiative and adaptability to problem situations.		
		3 - Can perform this skill satisfactorily without assistance or supervision.		
		2 - Can perform this skill satisfactorily but requires some assistance and/or supervision.		
		1 - Can perform parts of this skill satisfactorily, but requires considerable assistance and/or supervision.		
Note: Instructor will initial level achieved.				

PERFORMANCE STANDARDS For acceptable achievement, all items should receive a "Yes" or "N/A" response.	Yes	No	N/A

After gaining knowledge from the previous activities, you are ready to learn about official documents and other related forms pertaining to involve when you need drafting materials, drawing tools and instruments needed in preparing mechanical drawings. Now proceed to another learning experiences. Enjoy and have fun!

LEARNING OUTCOME 2

Request, receive, inspect and store drafting materials and tools

PERFORMANCE STANDARDS

1. Received and inspected materials and tools per quantity and specification based on requisition.
2. Tools and materials are checked for damages and manufacturing defects.
3. Received materials and tools/instruments are handled with appropriate safety devices.



Materials

- Sample forms in requesting, receiving, inspecting and storing drafting materials and tools, drawing instrument
- Pencils/ mechanical pencils



What Do You Already Know?

Let us determine how much you already know about requesting, receiving and inspecting drafting materials and tools/drawing instruments. Take this test.

Pretest LO 1

Directions: Read the statement carefully. Write the letter of the correct answer on a separate sheet of paper.

- This form shows proof or receipt of goods or services.
A. delivery receipt form
B. inventory form
C. purchase order form
D. requisition slip form
- This form contains specified quantities of described goods at agreed terms and at a designated time and place.
A. delivery receipt form
B. inventory form
C. purchase order form
D. requisition slip form
- This form is a printed document on which a request is made.
A. delivery receipt form
B. inventory form
C. purchase order form
D. requisition slip form
- This form contains information about name, number, purchase information and cost of goods and displays on a balance sheet.
A. delivery receipt form
B. inventory form
C. purchase order form
D. requisition slip form
- This department is in-charge of unloading, unpacking of incoming materials, check, identify goods received with descriptions on the purchase order.
A. accounting department
B. budget department
C. receiving department
D. sales department

Compare your answers using the Answer Key. If you got 90-100% of the items correct, that means you are already familiar with the lesson covered by Learning Outcome No. 2. Therefore you can proceed to the next activity.

If you got many items wrong, study the lesson again. Carefully reviewing the lesson helps you understand the concepts better. This also helps you learn the skills to mastery level. Concentrate on the parts that cover the questions you missed. After this, you are very much ready to proceed to the next learning activity.



What Do You Need To Know?

Read the Information Sheet very well then find out how much you can remember and how much you learned by doing Self-check 1.2.

Information Sheet 1.2

PROCEDURES IN RECEIVING AND STORING TOOLS AND MATERIALS

The Receiving Department unloads and unpacks incoming materials. They check quantities received against the shippers packing list; identify goods received with descriptions on the purchase order; prepare a receiving report; notify the purchasing department of descriptions discovered; arrange for inspection when necessary; notify the purchasing department of any damage in transit; and route accepted materials to the appropriate manufacturer's location.

The receiving and storing form also provides a space for the inspection department to note either the complete approval of the shipment or the quantity rejected and the reason for the rejection, if inspection does not take place immediately after receipt of the materials, the receiving report is distributed as follows:

The receiving department keeps one copy and sends another copy to the purchasing department as notice of the arrival of the materials.

All other copies go to the inspection department, and are distributed when inspection is completed. After inspection, one copy of the receiving report, with the inspection result is sent to the accounting department, where it is matched with the purchase order and the vendors invoice and the paid. Other copies go to various departments such as materials and production planning. One copy accompanies the materials, so that the storekeeper knows the quantity and the kind of materials received.

INVENTORY

Inventory is the collection of the idle stock of physical goods that contain economic value, and are held in various forms by an organization in its custody awaiting packing, processing, transformation, use or sale in a future point of time

INVENTORY FORM

The Inventory form contains information about items (name, number, sales and purchase information, and cost of goods sold account information) that any business purchases for sale, tracks in inventory, and displays on a balance sheet.

VARIOUS FORMS

Accurate entry in different forms used in drafting works is essentially important in order to purchase right, accurate and complete number of drawing materials, tools and instruments needed in a specific drafting job. Here are sample various forms used in drafting works.

A. Sample Requisition Slip Form

This is an official paper in the form of a printed document on which a request is made.

Name:

Project:

Classification:

Purpose:

NO.	QUANTITY	UNIT	DESCRIPTION	UNIT PRICE	TOTAL PRICE

Requisitioner

Teacher

Department Head

Principal

B. Sample Purchase Requisition Form

Below is a sample purchase requisition form. For standard materials, little information other than the stock number may be needed and for other purchases requests, it may be necessary to give particular descriptions, blueprints, catalog numbers, weights, standards, brand names, exact quantities to order, and suggested prices. One copy remains with the originating employee, and the original is sent to the purchasing department for execution of the request.

Purchase Requisition				
To Purchasing Department				
Deliver to _____			Date Required _____	
			Dept. No. _____	
			Acct. No. _____	
Suggested Supplier _____				
Qty	Item No.	Description	Unit Price	Amount
Budget Control				
Allowance for period _____		Balance Available _____	Ordered By _____	
		Amt This Purchase _____	Approved By _____	
		Remaining Balance _____		

C. Sample Delivery Receipt Form

Delivery receipt form shows proof or receipt of goods or services. The receiver acknowledges receiving a consignment of goods from supplier. The buyer signs it before it is returned to the seller. This officially takes care of uncertainties on the part of the supplier who gets to know the safe and timely arrival of goods to their designated destination.

Name of Supplying Company: _____

Delivery Receipt: _____

Supplier's Address: _____

Date: _____

NO.	QUANTITY	DESCRIPTION	UNIT PRICE	TOTAL PRICE

I hereby acknowledge receipt of the following in perfect condition as per the set of conditions of our supply contract from the firm of _____ (Name of supplying company).

Order No.: _____

Quantity	Description		Remarks

Invoice No.: _____

Date actually received: _____

D. Sample Inventory Form of Drawing Tools and Instruments

Name:
 Year & Section:
 School/Department:
 Laboratory/Shop:
 Purpose:

Tools/ Instruments	Qty.	No. Of Usable	No. Of Not Usable But Repairable	No. Of Condemn -Able	No. Of Borrowed	No. Of Missing

Requisitioner Teacher Department Head Principal

E. Sample Borrower's Slip

Name of Borrower: _____ Date: _____

Description	Quantity	Remarks

Signature of Borrower

Noted by:

Date Returned: _____

Personnel In-Charge

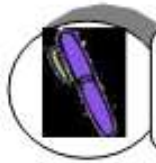

How Much Have You Learned?

Self-Check 1.2

TEXT TWIST

- A. Directions:** Under column A are jumbled letters coinciding with the different types of forms used in drafting when requesting, receiving and inspecting needed materials, tools and instruments. Arrange it to form the correct word or words.

Column A	Column B
1. ROIFYVT MNOENF	1.
2. RLVCDPYT EEEEIIR	2.
3. PRESO ROBRWIL	3.
4. SODEAR CUPREAH	4.
5. FITIMEON SIRUROQ	5.

Refer to the Answer Key. What is your score?

- B. Direction:** Describe briefly at least two (2) of your correct answers in Part A.

1.

_____.

2.

_____.



**Congratulations!
You did a great job! Rest and relax a
while then move on to the next
lesson. Good luck!**

REFERENCES

LO1

- Giesecke, Mitchell and Spencer, Technical Drawing; The Macmillan Company: 1999
- German M. Manaois, Drafting 1 and 2; Phoenix Publishing: 1983
- Esguerra and Molino, Exploratory Drafting; Abiva Publishing: 1980
- Stirling, Norman, Introduction to Technical Drawing, Metric Edition
- <http://www.images.search.yahoo.com/search/image>

LESSON 2

Perform Basic Mensuration and Calculation

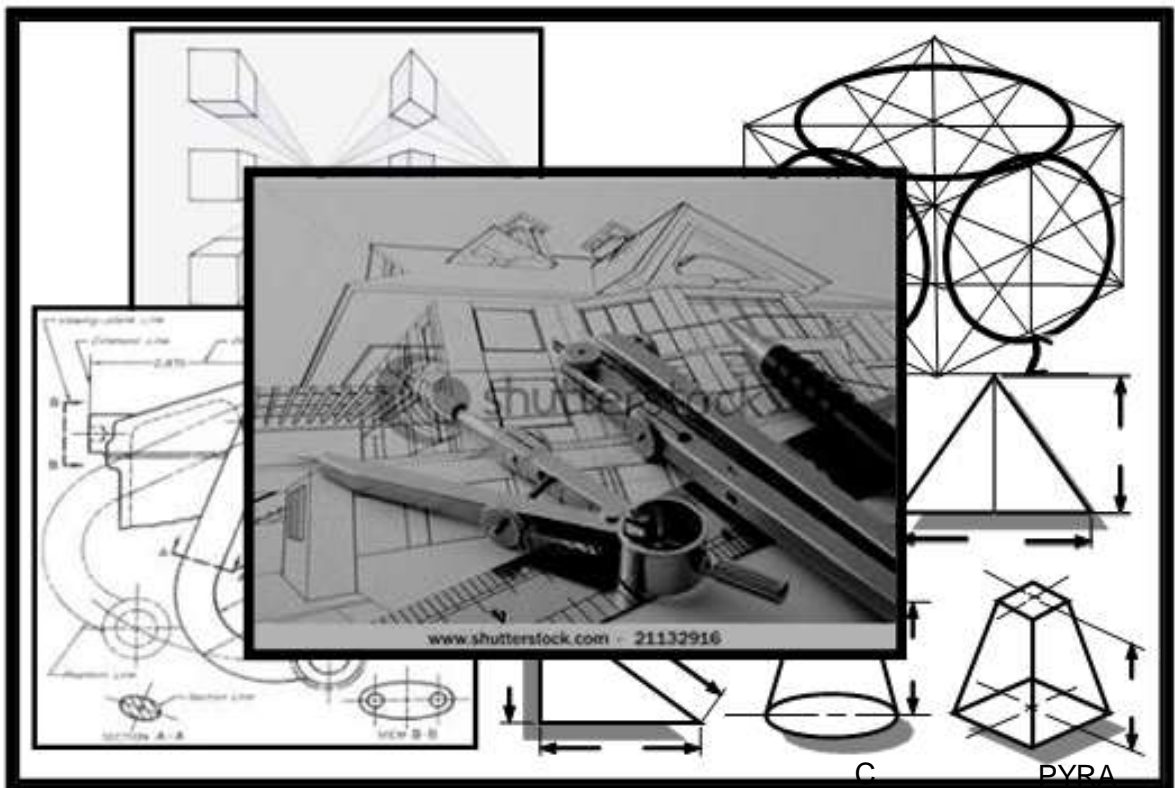

LEARNING OUTCOMES:

At the end of this Lesson, you are expected to do the following:

- LO 1. select and use measuring instruments;
- LO 2. clean and store measuring instruments; and
- LO 3. convert fraction to decimal and vice versa
- LO 4. convert English to Metric measurement



Definition of Terms

Angle - geometrical figure composed of two straight lines intersecting at one of their extremities

Calculation - act or process of or result of calculating

Circle - closed curve where all points are equally distant from the center

Concentric circles - consist of two or more circles with a common center.

Decimal - number expressed in a counting system that uses units of 10, especially a decimal fraction

Dimension - measurable extent of length, thickness and width

Eccentric circles - circles having no common center.

English system - scaled in inches where one foot equals 12 inches.

Formula - special kind of equation. It is a mathematical rule expressing the relationship of two or more quantities by means of numerals, variables and operating symbols

Geometric shapes - characterized by straight lines, regular curves, and angles

Graduation - scale of a measuring tool

Mensuration - act of measuring

Metric system - system of measurement based on the meter

Perpendicular lines - lines which make a 90° angle with each other

Radius - length of a straight line connecting the center of a circle with a point on the circumference of a circle.

Standard - measure of reference

LEARNING OUTCOME 1

Select and use measuring instruments

PERFORMANCE STANDARDS

1. Measuring instruments are selected and used according to the level of accuracy required.
2. Measurements taken are accurate to the finest gradation of the selected measuring instrument.
3. Measuring techniques used are correct and appropriate to the instrument used.



Materials

- T- square
- Triangles 30 x 60 and 45 x 45
- Pencils/ mechanical pencils
- Compass
- Drawing paper
- Drawing board
- Scale
- Eraser
- Erasing shield
- Protractor



What Do You Already Know?

Let us determine how much you already know about the of measuring instruments in mechanical drafting. Take this test.

Pretest LO 1

Directions: Multiple Choices. Choose the letter of the best answer.

1. A measuring tool used to layout an angle or an arc.
A. Compass B. Divider C. Protractor D. Tape ruler
2. The most popular type of measuring tools, usually 6 or 12 inches in length.
A. Tape ruler B. Triangle C. Ruler D. Scale
3. Its main purpose is to reproduce, reduce or enlarge the dimension of size on a drawing.
A. Tape ruler B. Triangle C. Ruler D. Scale
4. It is used for drawing vertical and oblique lines.
A . Ruler B. Scale C. Triangle D. T- Square
5. It provides an easy means for accurately measuring curved surfaces.
A. Compass B. Divider C. Protractor D. Tape ruler
6. These are used for the purpose of measuring dimensions.
A. Cutting Tools B. Measuring Tools C. Lining Tools D. Testing Tools
7. This is used as guide in drawing horizontal lines.
A . Ruler B. Scale C. Triangle D. T- Square
8. This instrument is used to draw circles, arcs, radii, and parts of many symbols.
A. Compass B. Divider C. Protractor D. Tape ruler
9. It is a concave, spring-steel blade ranging from 1/4" to 1" wide and 6 to about 300 feet in length
A. Meter stick B. Tape ruler C. Triangle D. Ruler
10. It helps a drafter keep the proportions accurate.
A . Ruler B. Scale C. Triangle D. T- Square

Now check your answers using the Answer Key . If you got 90-100% of the items correctly, proceed to the next Activity.

If not, carefully reviewing the lesson helps you understand the concepts better. This also helps you learn the skills to mastery level. Concentrate on the parts that cover the questions you missed. After this, you are very much ready to proceed to the next learning activity.



What Do You Need To Know?

Read the Information Sheet very well then find out how much you can remember and how much you learned by doing Self-check 1.1.

Information Sheet 1.1

Different Measuring Tools/instrument and their application

An understanding of measurement is essential for all parts of manufacturing and production technology. Measurements must be uniform so that people have common understanding and application in the production and use of manufactured objects.

Measuring tools are used for the purpose of measuring dimensions, implementing any work with precision. The measuring tools are also used largely for carrying out different types of measurements.

Importance of Measuring Tools

Measuring tools are essential for examining a finished product or semi-finished product. The inspection or examination operations include checking, or testing an object based on the required dimensions given on a diagram or a sketch. Measurements taken must be accurate.

Different Measuring Tools

1. **T-Square** is used as guide in drawing horizontal lines and in measuring up to 48" straight line.

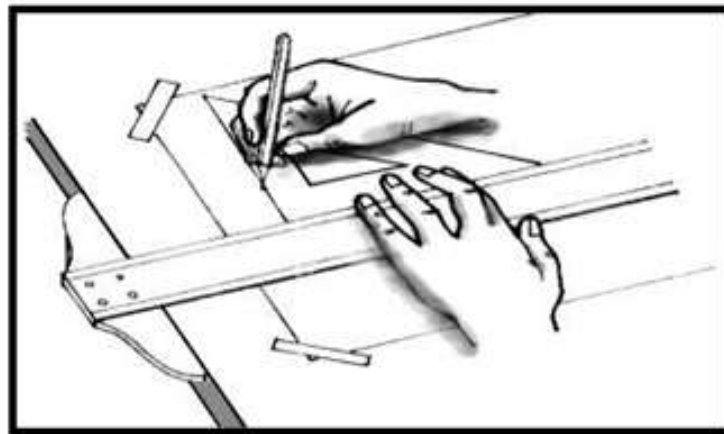
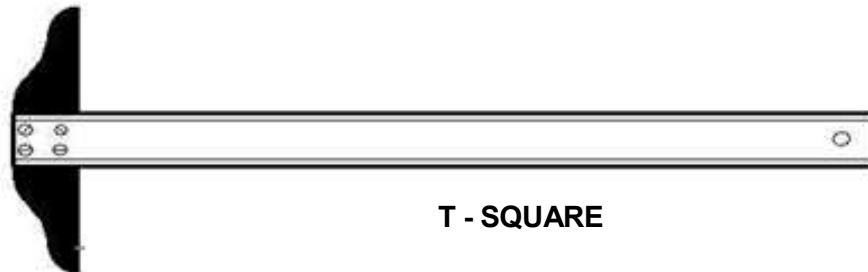

2. **Triangles** are used for drawing vertical and oblique lines. The most commonly used triangles are the 45° and the 30°x 60°. Illustrations below show the proper use of drawing lines and measuring angles using the T-square and triangle.

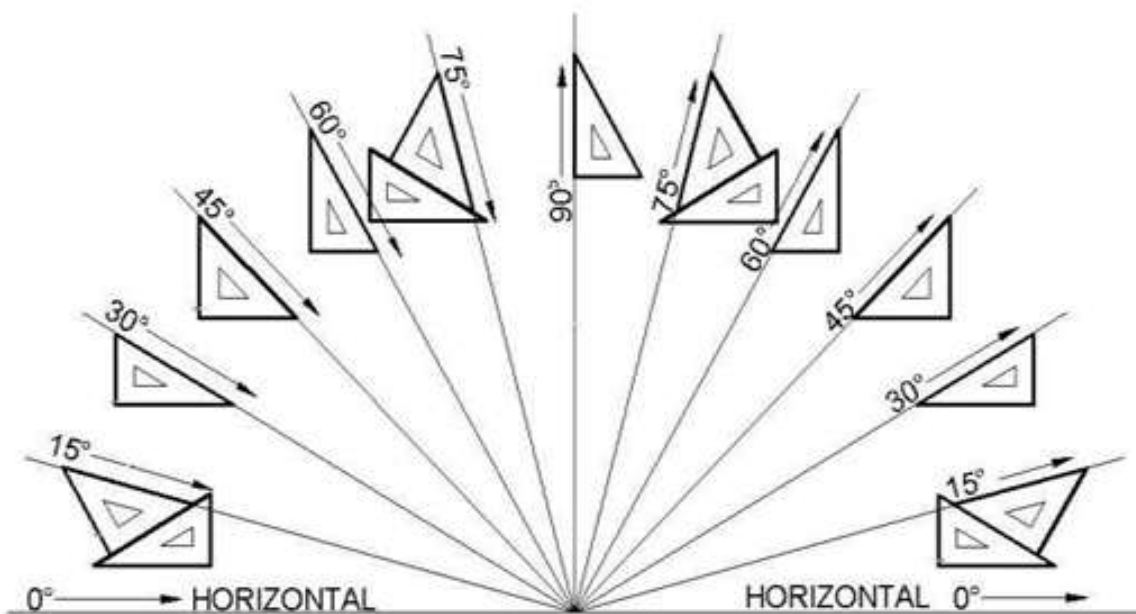

TRIANGLES

3. **Ruler** is the most popular type of measuring tool. It is usually 6 or 12 inches in length. It is needed for measuring sizes and distances.

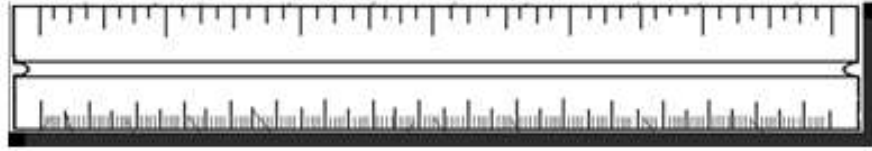

RULER

4. **Triangular Scale** is used in general drawing. Its main purpose is to reproduce the dimension in full size or to reduce or enlarge them on a drawing. Scales help a drafter keep the proportions accurate.

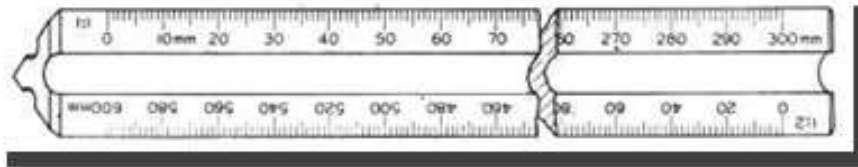

TRIANGULAR

Steps in Using a Scale

- Place the edge of the scale parallel to the line being measured.
- Face the edge of the scale that you're reading toward your non dominant side (if it's oriented vertically) or away from you (if it's oriented horizontally). This helps keep you from casting shadows on the relevant face of the scale as you work.
- Make light marks to indicate the distance you're measuring or drawing out, as measured by the scale.
- Adjust dividers with the scale by making a pencil line as long as the dividers should be wide, using the scale as a guide. Then adjust the dividers by orienting the points on the ends of the pencil line. Adjusting the dividers by placing the points directly on the scale might nick the surface of the scale, making it hard to read.

5. **Protractor** is used for measuring and setting of angles other than those obtainable with the triangles.

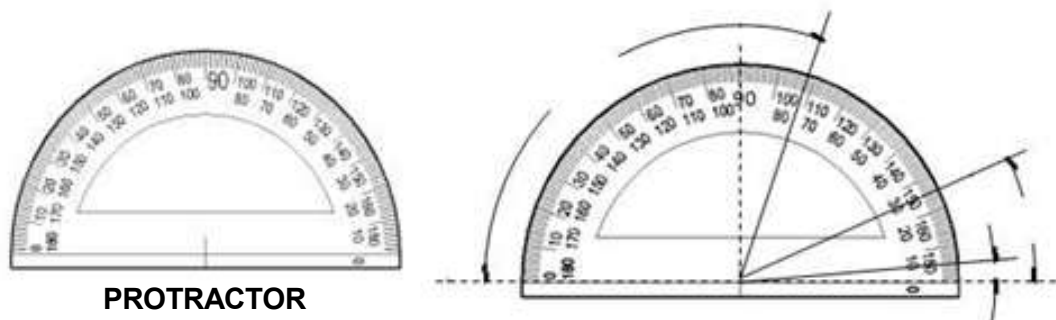

PROTRACTOR

□ Figure below can be measured and drawn using a protractor

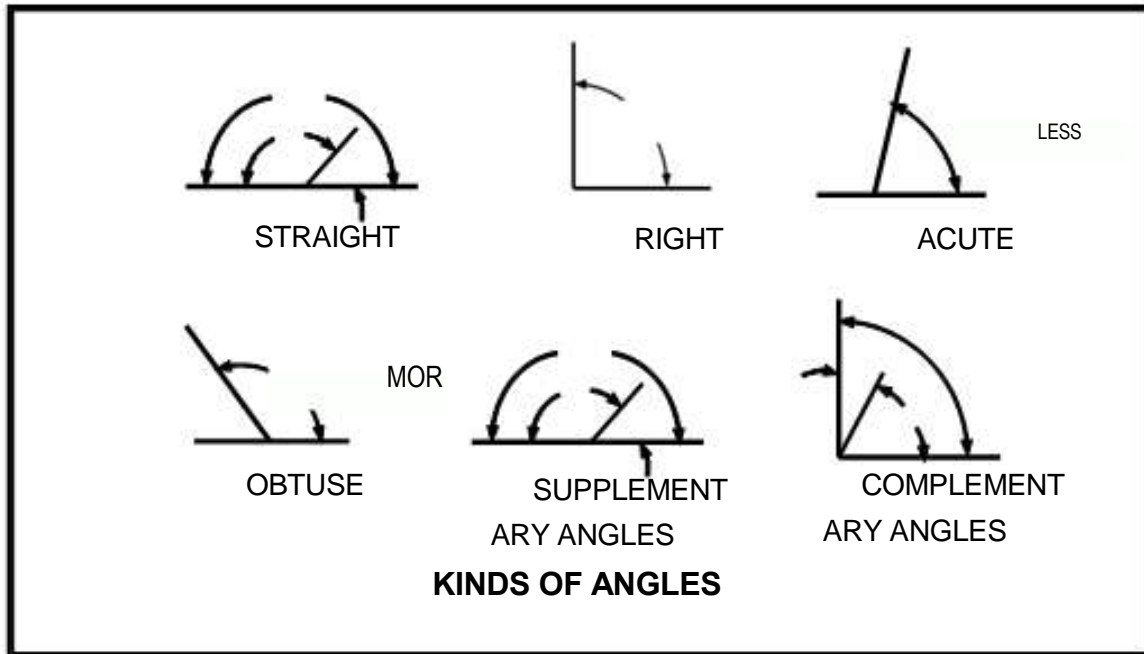

6. **Tape or tape ruler** is a concave, spring-steel blade ranging from 1/4" to 1" wide and 6 to about 300 feet in length, coiled inside a carrying case. Metric tape ruler comes in comparable widths and lengths up to 10 meters. It provides an easy means for accurately measuring curved surfaces.



TAPE OR TAPE RULER

7. **Compass** is used to draw circles, arcs, radii, and parts of many symbols.



Steps in Using a Compass



COMPASS

- a. Place the point of the drafting compass at the center point of the circle you intend to draw. If you're drawing an arc, imagine that the arc extends all the way around into a circle and place the point of the compass at the center of that imaginary circle.
 - b. Adjust the leaded end of the compass so that it touches where you'd like the edge of the arc--or circle--to be. If you're drawing an arc at a specific distance from the center point, make a line of the desired distance, adjust the point and leaded end of the compass against the ends of that line, then place the point of the compass back at the center point of your circle or arc.
 - c. Grasp the middle of the compass between your thumb and fingers. Twist your fingers, applying light downward pressure on the compass to mark out the desired length of arc or circle with the leaded end of the compass.
8. **Divider** is similar to the compass in construction. As the name implies, divider is used for dividing distances into a number of equal parts by the trial-and-error method.

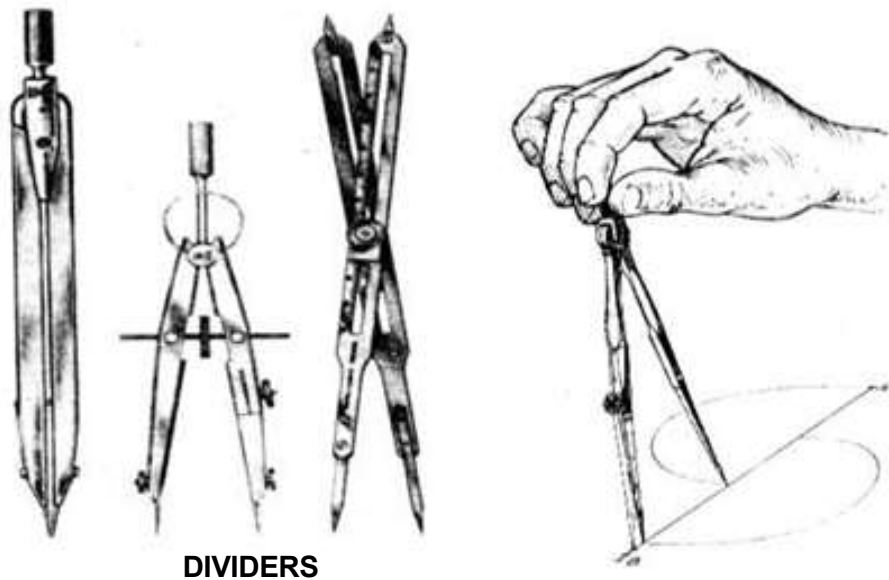

DIVIDERS

Steps in Using a Divider

- a. Align each arm of the dividers so that one point is laying on the start point of the measurement you want to transfer and the other divider point is laying on the endpoint of that same measurement.
- b. Lift the dividers off the measurement you intend to transfer, being careful not to change their alignment.
- c. Place the dividers over the location you'd like to transfer the measurement to, and make a pencil mark to indicate where each of the dividers' pointers sits. This duplicates the measurement.



How Much Have You Learned?

Self-Check 1.1

Direction: Match Column A with Column B. Write only the letter of the correct answer on a separate sheet of paper.

Column A

1. It is the measuring tool used for measuring and setting of Angles
2. It is the most popular type of measuring tools, usually 6 or 12 inches in length.
3. Its main purpose is to reproduce, reduce or enlarge the dimension of size on a drawing.
4. It is used for drawing vertical and oblique lines.
5. It provides an easy means for accurately measuring curved surfaces.

Column B

- A. Triangle
- B. Tape Ruler
- C. Protractor
- D. Scale
- E. Ruler
- F. Divider

Refer to the Answer Key. What is your score?

Directions: Name the different measuring tools shown below. Use a separate sheet for your answer.

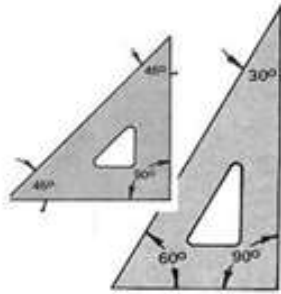

1. _____



2. _____

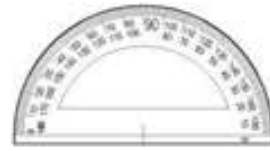

3. _____

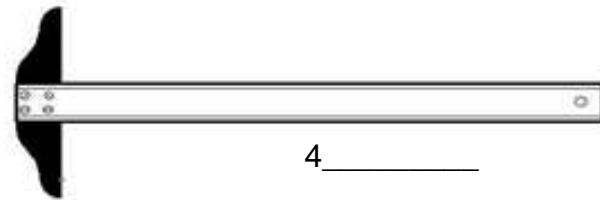

4. _____



5. _____

If all or almost all (90-100%) your answers are correct, that is great. You may now proceed to the next Activity.

If you got some items wrong, study the lesson again. Carefully review the lesson to help you understand the concepts better. Concentrate on the parts that cover the questions you missed. After this proceed to Activity 1.1.



How Do You Apply What You Have Learned?

It is not enough that you learned concepts on the use of measuring instruments. Be sure that you are also able to demonstrate the skill on how to use the measuring instruments. Do this Activity Sheet.

Activity Sheet 1.1

Actual Usage of Measuring Instruments

The activity below is purposely required to test your retention of the actual usage of measuring instruments.

Supplies and Materials

- Drawing paper
- pencil

Tools and Equipment

- Measuring Instruments

PROCEDURE:

This is a group activity.

- a. Group yourselves into two.
- b. Assign a leader for each group.
- c. Each group shall be provided with complete measuring instruments
- d. Each group will be given fifteen minutes to demonstrate the uses of measuring instruments.
- e. A leader or any member of the group will explain the functions as well as the steps in using the tools during the demonstration.
- f. Performance of the group may be evaluated through a Demonstration Checklist provided each member of the group.



How Well Did You Perform?

Find out by accomplishing the Scoring Rubric honestly and sincerely.
Remember it is your learning at stake!

DEMONSTRATION CHECKLIST

Student's name:			
Teacher's name:			
Unit of competency:	<i>Perform Basic Mensuration and Calculation</i>		
Competency standards:	<i>Uses of Measuring Instruments</i>		
Date of assessment:			
Time of assessment:			
Instructions for demonstration			
Given the necessary materials the student must be able to use the measuring instruments correctly.			
Materials and equipment:			
<ul style="list-style-type: none"> T-square Triangles Protractor Compass and Divider Tape ruler Ruler Other measuring instruments 			
	☞ to show if a skill is demonstrated		
During the demonstration, the student can:	Yes	No	N/A
Perform this skill without supervision and with initiative and adaptability to problem situations.	<input type="checkbox"/>	<input type="checkbox"/>	<input type="checkbox"/>
Perform this skill satisfactorily without assistance or supervision.	<input type="checkbox"/>	<input type="checkbox"/>	<input type="checkbox"/>
Perform this skill satisfactorily but requires some assistance and/or supervision.	<input type="checkbox"/>	<input type="checkbox"/>	<input type="checkbox"/>
Perform parts of this skill satisfactorily, but requires considerable assistance and/or supervision.	<input type="checkbox"/>	<input type="checkbox"/>	<input type="checkbox"/>
The student's demonstration was:			
Satisfactory <input type="checkbox"/>		Not Satisfactory <input type="checkbox"/>	

How did your group fare? How did you as a member perform? Do you think you contributed much to the group performance? In what way?

It is not enough that you learned concepts on the use of tools. Be sure that you are also able to demonstrate the skills on how to use tools. Do this Operation Sheet.

Operation Sheet 1.1

Drawing of lines, angles and circles

Supplies and Materials

- Drawing paper
- pencil

Tools and Equipment

- Measuring Instruments

Direction: By using the correct measuring tools or instruments, draw the sample figures below.

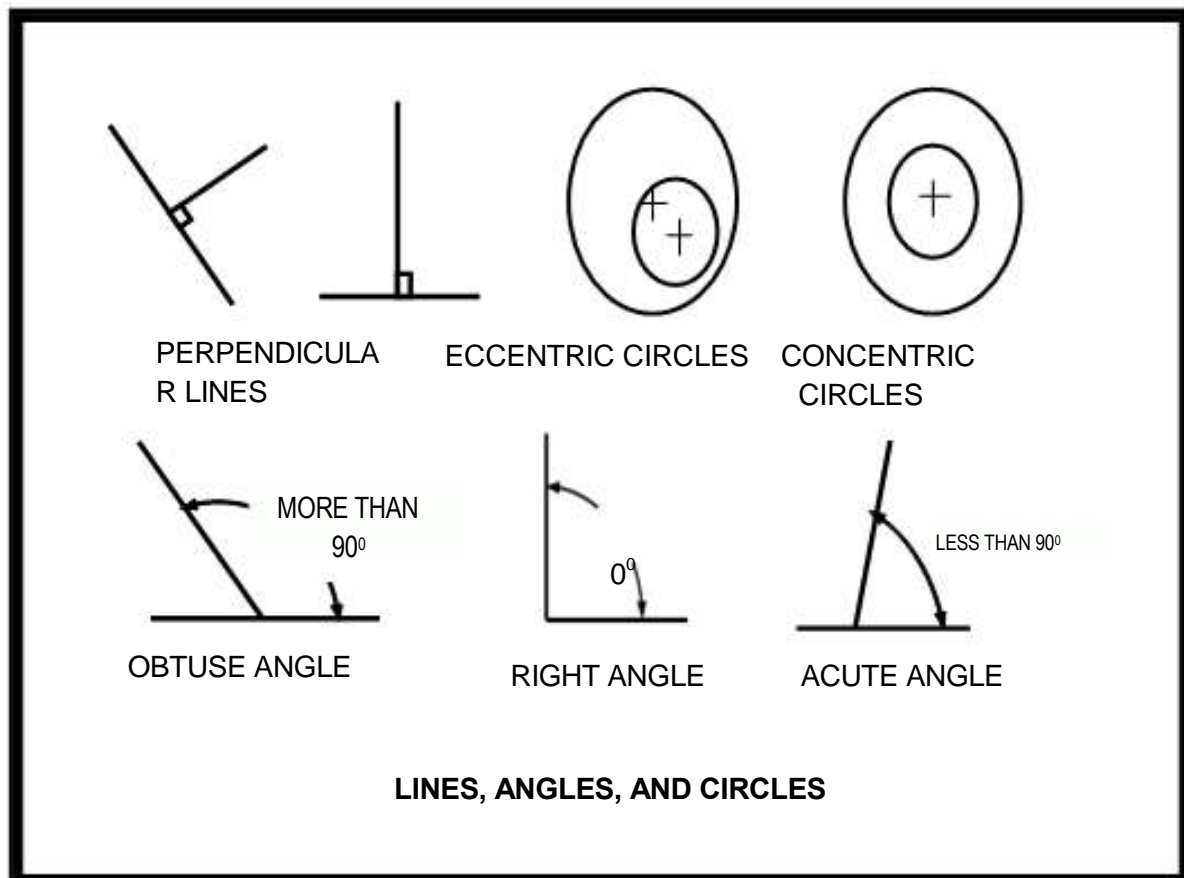

**Find out by accomplishing the Scoring Rubric honestly and sincerely.
Remember it is your learning at stake!**

Criteria for Assessment: Analytic Rubrics Scoring

CRITERIA	5 points	3 points	1 point
Accuracy	The output is accurately done without any help from the teacher.	The output is satisfactorily done with some guidance from the teacher.	The output is done under the supervision of the teacher
Layout/Presentation	The output is properly laid out and satisfactorily presented.	The output is satisfactorily laid out and presented with some guidance from the teacher.	Layout and presentation fairly done even with the guidance of the teacher.
Speed	The output is done on or before the given time.	The output is done after the allotted time.	The output is not thoroughly finished even after the given deadline.
Neatness	The output is free from any erasures.	The output has one to three erasures.	The output has four or more erasures.

Rating Scales

POINTS EARNED	NUMERICAL	DESCRIPTIVE
15 - 20	90 - 100	Very Good
10 - 14	86 - 90	Good
5 - 9	81 - 85	Fair
1 - 4	75 - 80	Needs Improvement

LEARNING OUTCOME 2

Clean and store measuring instruments

PERFORMANCE STANDARDS

1. Measuring instruments are cleaned in accordance with established standards.
2. Measuring instruments are stored in accordance with established standards.



Materials

- T- square
- Triangles 30 x 60 and 45 x 45
- Pencils/ mechanical pencils
- Compass
- Drawing paper
- Drawing board
- Scale
- Eraser
- Erasing shield
- Protractor



What Do You Already Know?

Let us determine how much you already know about use and care of drafting/measuring tools. Take this test.

Pretest LO 2

- A. : Match Column A with Column B. Write only the letter of the correct answer on a separate sheet of paper.

Column A

- 1 A measuring tool used to layout an angle or an arc.
- 2 It is the most popular type of measuring tools, usually 6 or 12 inches in length.
- 3 Its main purpose is to reproduce, reduce, or enlarge the dimension or size on a drawing.
- 4 It is used for drawing vertical and oblique lines.
- 5 It provides an easy means for accurately measuring curved surfaces

Column B

- A. Triangle
- B. Tape Ruler
- C. T-Square
- D. Scale
- E. Ruler
- F. Protractor

- B. List down at least five uses and care of drafting or measuring tools.

- 1.
- 2.
- 3.
- 4.
- 5.

Now check your answers using the Answer Key. If you got 90-100% of the items correctly, proceed to the next Learning Outcome.

If not, carefully review the lesson to help you understand the concepts better. This also helps you learn the skills to mastery level. Concentrate on the parts that cover the questions you missed. After this, you are very much ready to proceed to the next learning activity.



What Do You Need To Know?

Read the information sheet very well then find out how much you can remember and how much you learned by doing Self-check 2.1.

Information Sheet 2.1

It is better to own a few good tools than a number of poor ones. In acquiring tools, be guided by quality and durability. Quality tools are known by their popular trademark. But also consider that the life of any drawing or measuring tools will depend on how well you take care of them. Drafting measuring tools should be well maintained to continue working properly. Organizing and storing these items have a great deal to do with keeping them in tiptop shape and good working condition. You can assure that your tools will last long if you patiently and religiously take care of them.

Good workmanship is associated with the use of quality hand tools. Maintaining effective use of drafting tools in the production of quality projects is the concern of every craftsman.

A good tool is a lifelong investment and the craftsman's best friend. Treat it as such and you'll be repaid a thousand times through the results you will obtain from its use.

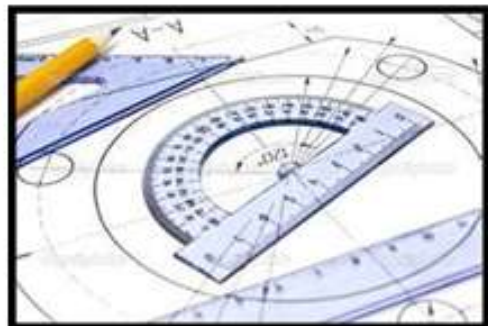
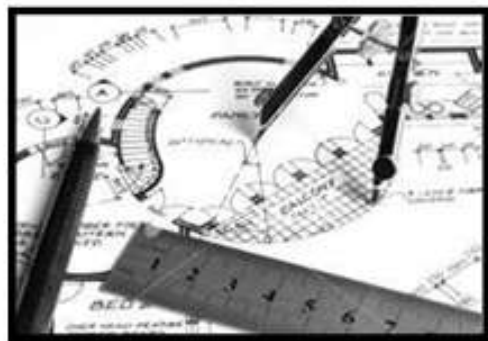

Clean/Store Drafting Measuring Tools

1. Be sure to inspect tools before using them. This is to check if they are in working condition. This can be detected when there is ease and speed when in use.
2. After using a tool, clean it thoroughly with a damp cloth. Wipe it dry with another piece of cloth before keeping it.
3. When not in use, the T-square is preferably hung by inserting the hole to a nail (attached to a wall) at the end of its blade.
4. Do not abuse or misuse any piece of drawing instruments.
5. Avoid throwing a tool to anybody; instead, hand it over to him carefully.
6. Avoid setting off the distances individually by moving the scale to a new position from time to time, because slight errors in the measurements may accumulate and give rise to a large error.
7. Avoid unnecessary sliding of T-square or triangles to protect the drawing. Pick up the triangle by its tip and tilt the T-square blade upward slightly before moving.
8. Do not pull too much of the steel tape of pull-push rule to the coil spring to avoid damage.
9. Oil the movable parts of the measuring tools such as zigzag rules, calipers, dividers, and compasses to avoid stock-up.
10. Report defective measuring tools and any hazard to instructor immediately.

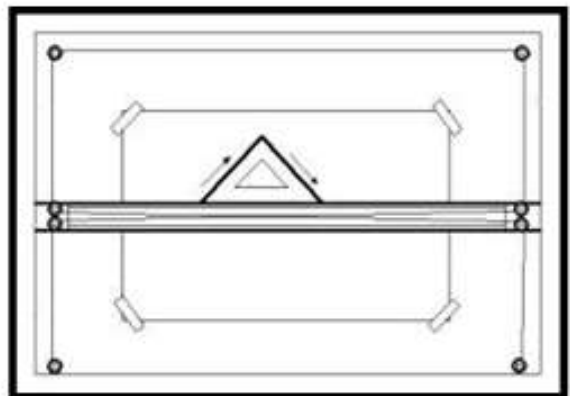
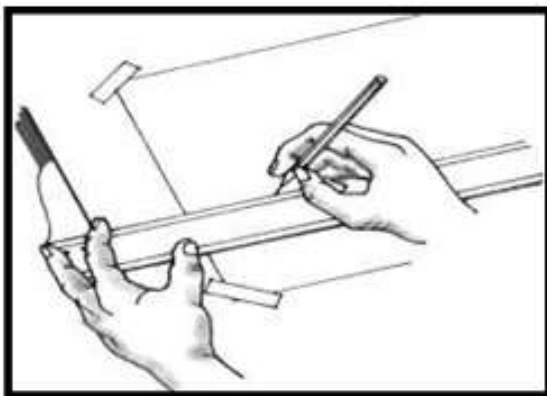



How Much Have You Learned?

Self-Check 2.1

A. **Directions:** Write **T** if the statement is **True** and **F** if the statement is **False**.
Write your answer in your notebook.

- _____ 1. Avoid unnecessary sliding of T-square or triangles across the drawing
- _____ 2. T-square is preferably hung when not in use.
- _____ 3. Report defective measuring tools and any hazard to instructor immediately
- _____ 4. After using a tool, clean it thoroughly with a damp cloth.
- _____ 5. Be sure to check and then clean tools before and after using them.

B. List down at least five uses and care of drafting or measuring tools.

6.

7.

8.

9.

10. _____

Refer to the Answer Key. What is your score?

LEARNING OUTCOME 3

Convert fraction to decimal and vice versa

PERFORMANCE STANDARDS

1. Conversion results of fraction to decimal are accurate up to 2 decimal place.
2. Conversion results of decimal to fraction are accurate to the nearest standard measurement.



Materials/Resources

- Pencils/ mechanical pencils
- Ball pen
- Eraser
- Drawing paper / Pad paer
- Drawing board



What Do You Already Know?

Let us determine how much you already know about the conversion of fraction to decimal and decimal to fraction. Take this test.

Pretest LO 3

Directions: Convert the following . Write your answers on a separate sheet of paper.

TEST I. - A. Convert fractions into decimals .

1. $\frac{1}{4}$ to decimal
2. $\frac{3}{4}$ to decimal
3. $\frac{7}{16}$ to decimal
4. $\frac{3}{8}$ to decimal
5. $\frac{1}{8}$ to decimal

B. Convert decimals into fractions .

6. 0.35
7. 0.24
8. 0.75
9. 0.125
10. 0.150

TEST II. Round off the following numbers to their nearest hundredths.

11. 76.3456
12. 93.674
13. 27.009
14. 4.6245
15. 5.2532

Check if your answers are correct by comparing them with those in the Answer Key.

If you got 90-100% of the items correct, that means you already familiar with the lesson covered by Learning Outcome No. 3. However you may still study the lesson to refresh your memory and learn new concepts.

If you missed a lot of items, do all the activities to gain knowledge and skills required for mastery.



What Do You Need To Know?

Read the Information Sheet very well then find out how much you can remember and how much you learned by doing Self-check 3.1.

Information Sheet 3.1

CONVERSION OF FRACTION AND DECIMAL

Changing Fractions to Decimals

Any rational number can be changed from fractional form to decimal form. This is done by simply dividing the numerator by the denominator.

Illustrative Examples

$$\begin{array}{r} \text{A.} \quad \frac{4}{5} \quad \frac{0.8}{5)4.0} \\ \\ = \quad \frac{40}{0} \end{array}$$

Therefore, $\frac{4}{5}$ equal 0.8

$$\begin{array}{r} \text{B.} \quad \frac{3}{4} \quad \frac{0.75}{4)3.00} \\ \\ = \quad \frac{28}{20} \\ \frac{20}{0} \end{array}$$

Therefore $\frac{3}{4}$ equal 0.75

$$\begin{array}{r} \text{C.} \quad \frac{1}{8} \quad \frac{0.125}{8)1.000} \\ \\ = \quad \frac{8}{8} \end{array}$$

1. If the first number to be eliminated is less than 5, simply drop it (and the number to the right of it) and let the last significant digit stand.

Example: Round off 25.4 mm to whole millimeter.

Solution: Simply drop the .4

Answer: 25

Example : Round off 0.3125 (5/16) into two significant digits.

Solution: The first number to be eliminated is 2: Simply drop it and all numbers to its right(5)

Answer:0.31

2. If the number to be eliminated is 5 or more, drop the number, then add one to the last digit retained.

Example:

- a. Round off 78.6 into its nearest ones.

Solution: The number to be rounded off is 6 which is greater than 5, drop 6 and add one to the last digit retained.

Answer: 79

- b. Round off 92.65 into its nearest tenths.

Solution: The number to be rounded off is 5, drop 5 and add one to 6 which is the last digit retained.

Answer: 92.7

Conversion of Decimals to Fractions

A decimal is changed to a fraction by using 10 or any power of 10 as denominator of the given decimal. Then change to lowest term when possible.

Illustrative Examples

$$\text{A. } 0.4 = \frac{\underline{4}}{10} \quad \text{or} \quad \frac{\underline{2}}{5}$$

$$\text{B. } 0.25 = \frac{\underline{25}}{100} \quad \text{or} \quad \frac{\underline{1}}{4}$$

$$\text{C. } 0.328 = \frac{\underline{328}}{1000} \quad \text{or} \quad \frac{\underline{82}}{250} \quad \text{or} \quad \frac{\underline{41}}{125}$$

Millimeters Equivalent of Decimals and Fractions of an Inch.

Fractions	Decimals	Millimeter
1/16	0.0625	1.588
1/8	0.1250	3.175
3/16	0.1875	4.762
1/4	0.2500	6.350
5/16	0.3125	7.938
3/8	0.3750	9.525
7/16	0.4375	11.112
1/2	0.5000	12.700
9/16	0.5625	14.288
5/8	0.6250	15.875
11/16	.6875	17.462
3/4	0.7500	19.050
13/16	0.8125	20.638
7/8	0.8750	22.225
15/16	0.9375	23.812
1	1.00	25.400

This table is used to find the equivalent decimal numbers and millimeters of a given fraction



How Much Have You Learned?

Self-Check 3.1

Directions:

A. Convert fractions into decimals. Write your answer on a separate sheet of paper.

1. $\frac{1}{4}$ to decimal
2. $\frac{3}{4}$ to decimal
3. $\frac{7}{16}$ to decimal
4. $\frac{3}{8}$ to decimal
5. $\frac{1}{8}$ to decimal

B. Round off the following numbers to their nearest hundredths.

1. 13.7556
2. 38.614
3. 41.009
4. 8.6245
5. 7.2532

C. Convert decimals into fractions . Write your answers on a separate sheet of paper.

1. 0.2
2. 0.8
3. 0.84
4. 0.35
5. 0.24
6. 0.75
7. 0.125
8. 0.150
9. 0.65
10. 0.375

Refer to the Answer Key. What is your score?

If you got many items wrong, study the lesson again. Carefully reviewing the lesson helps you understand the concepts better. This also helps you learn the skills to mastery level. Concentrate on the parts that cover the questions you missed. After this, you are very much ready to proceed to do activities in



How Do You Apply What You Have Learned?

Show that you learned something by doing this activity.

Activity Sheet 3.1

After learning the procedure in converting fraction to decimal;

1. inform your teacher that you are ready to solve problems in converting metric measurement to decimal and vice versa.

2. convert the following measurements from fractions to decimal.
 - a) $\frac{5}{16}$
 - b) $\frac{1}{3}$
 - c) $\frac{3}{16}$
 - d) $\frac{7}{8}$
 - e) $\frac{5}{32}$

3. When you finish answering, check your work again before submitting it to your teacher for verification and recording. If your work pass the required output, you are now ready to proceed to the next activity. If not, make the necessary corrections then submit your work again.

LEARNING OUTCOME 4

Convert English to Metric measurement system and vice versa

PERFORMANCE STANDARDS

1. English to metric equivalent are presented.
2. Conversion of English to metric or metric to English is performed according to procedure.



Materials/Resources

- Pencils/ mechanical pencils
- Ballpen
- Drawing paper / Pad paper
- Drawing board
- Erase



What Do You Already Know?

Let us determine how much you already know about the conversion of metric to English measurement. Take this test.

Pretest LO 4

A. **Direction:** Convert the following. Write your answer and solution on a separate sheet. Round your answers into two decimal places.

1. 25 cm to = _____ inches
2. 63 m to = _____ feet
3. 50 ft to = _____ meters
4. 13 inches = _____ meters
5. 10 mm to = _____ inch

B. **Directions:** Write the correct measurements as indicated by extension lines below. Use a separate sheet of paper.

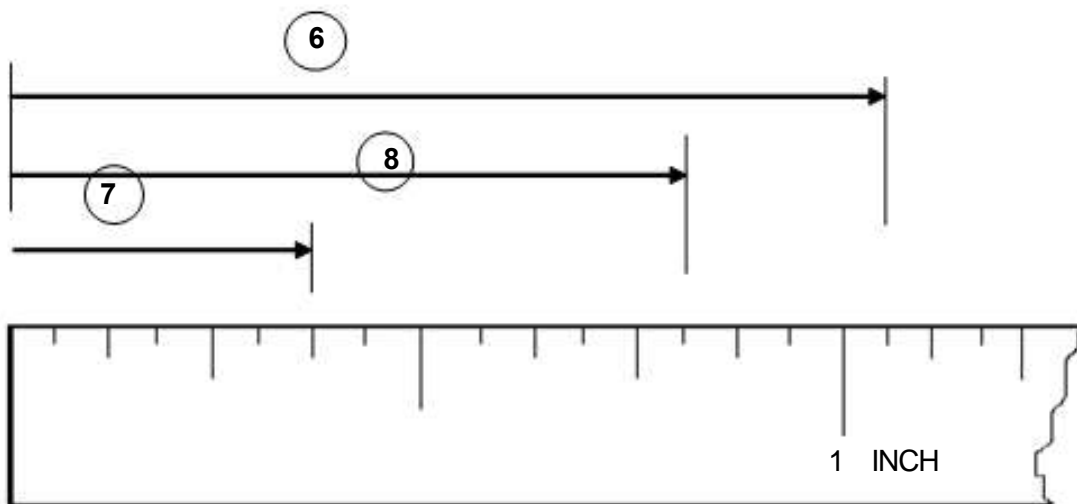

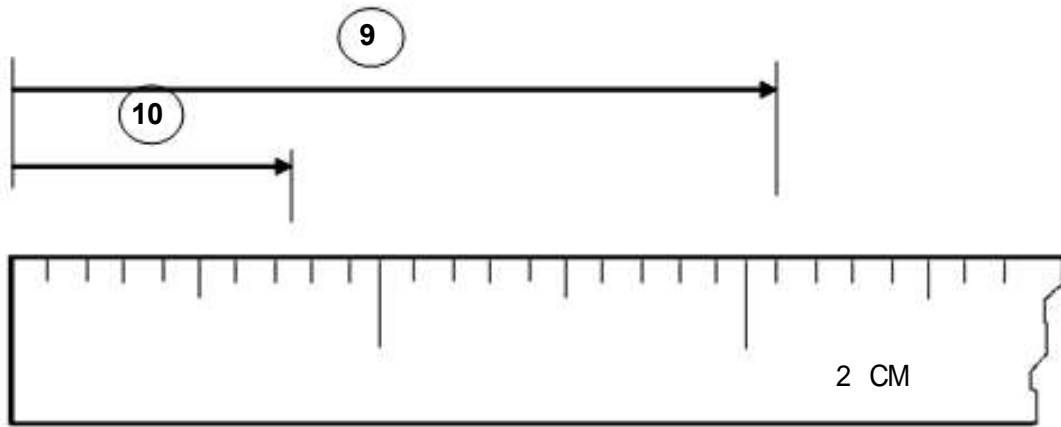

Compare your answers using the Answer Key. If you got 90-100% of the items correct, that means you are already familiar with the lesson covered by Learning Outcome No. 4. Therefore you can proceed to the next learning activity . If you missed a lot of items, do all the activities to gain knowledge and skills required for mastery



What Do You Need To Know?

Read the Information Sheet very well then find out how much you can remember and how much you learned by doing Self-check 1.1.

Information Sheet 4.1

TRADE MATHEMATICS / MEASUREMENT

Measuring accurately is a skill that should be developed. Inaccurate measurement would mean a waste of time, effort and materials. The development of the skill in measuring starts with the ability to read measurement

An orthographic or pictorial view of an object cannot be used as a working guide in the construction of an object without complete and accurate dimensions indicated in the drawing..

Two systems of measurement

There are two systems of measurement: the English system which originated in England and the Metric system or Systems International (S.I) which originated in France.

The basic unit in the Systems International measurement is called the meter. The meter is divided into 100 centimeters. Each centimeter is divided into 10 millimeters. They are abbreviated as follows:

Millimeters	mm
Centimeters	cm
Decimeters	dm
Meters	m

In the English system , the inch is divided into 16 graduations and the smallest graduation is read 1/16.

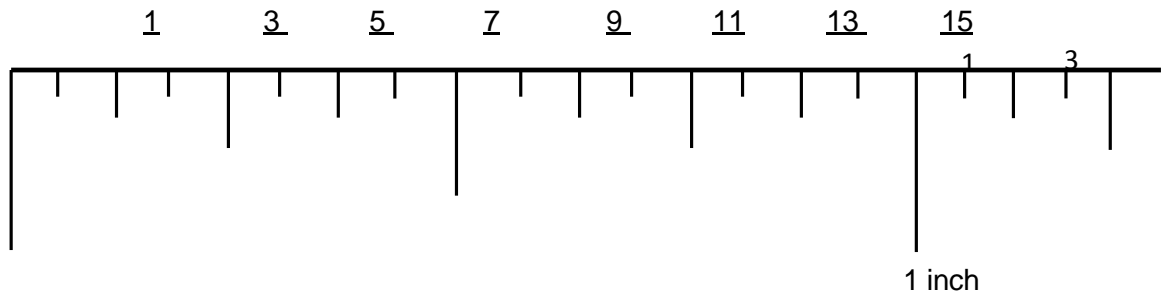

To read measurement exceeding 1 inch say 2" and for smaller graduations, it is read and written as: 2" 4/16 or 2 ¼.

1 foot + 2 inches + 3 smaller graduations, it is read and written as: 14" 3/16

In the Systems International measurement , the centimeter is divided into 10 millimeters. as shown below:

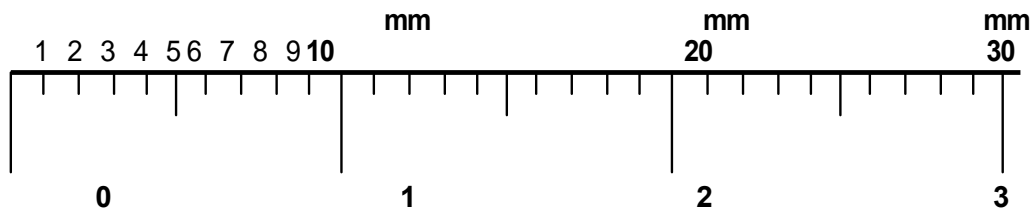

Metric System of Measurement

(linear equivalent)

10 millimeters (mm.)	=	1 centimeter (cm.)
10 centimeters (cm.)	=	1 decimeter (dm.)
10 decimeter (dm.)	=	1 meter (m.)
10 meters (m.)	=	1 decameter (Dm.)
10 decameter (Dm.)	=	1 hectometer (Hm.)
10 hectometer (Hm.)	=	1 kilometer (Km.)
10 kilometer (Km.)	=	1 mayriameter (Mn.)

English System of Measurement

(linear equivalent)

$$12 \text{ inches (in.)} = 1 \text{ foot (ft.)}$$

$$3 \text{ feet (ft.)} = 1 \text{ yard (yd.)}$$

Metric Conversion Table

$$1 \text{ millimeter} = 0.03937 \text{ inches (in.)}$$

$$1 \text{ centimeter} = .3937 \text{ inches (in.)}$$

$$1 \text{ meter} = 39.37 \text{ inches (in.)}$$

English Conversion Table

$$1 \text{ inch (in.)} = .0254 \text{ mm.} = 2.54 \text{ cm.} = .0254 \text{ (m.)}$$

$$1 \text{ foot (ft.)} = 304.8 \text{ mm.} = 30.48 \text{ cm} = .3048 \text{ (m.)}$$

$$1 \text{ yard (yd.)} = 914.4 \text{ mm} = 91.4 \text{ cm} = .9144 \text{ (m.)}$$

Conversion Formulas

$$\text{Length in inches} \times 0.0254 = \text{length in meters}$$

$$\text{Length in inches} \times 2.54 = \text{length in centimeters}$$

$$\text{Length in feet} \div 3.28 = \text{length in meters}$$

$$\text{Length in meters} \times 39.37 = \text{length in inches}$$

$$\text{Length in inches} \div 39.37 = \text{length in meters}$$

$$\text{Length in feet} \times 0.305 = \text{length in meters}$$

$$\text{Length in feet} \times 30.5 = \text{length in centimeters}$$



How Much Have You Learned?

Self-Check 1.1

Directions: Write the correct measurements as indicated by extension lines below. Use a separate sheet of paper.

A. English System

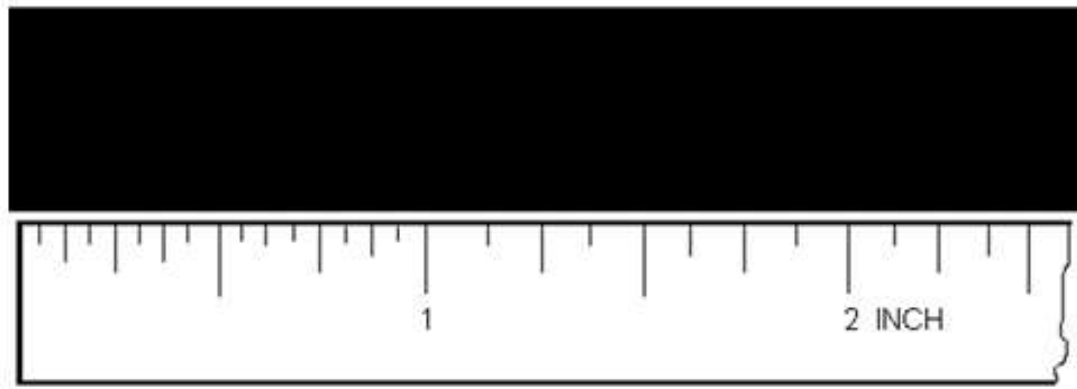
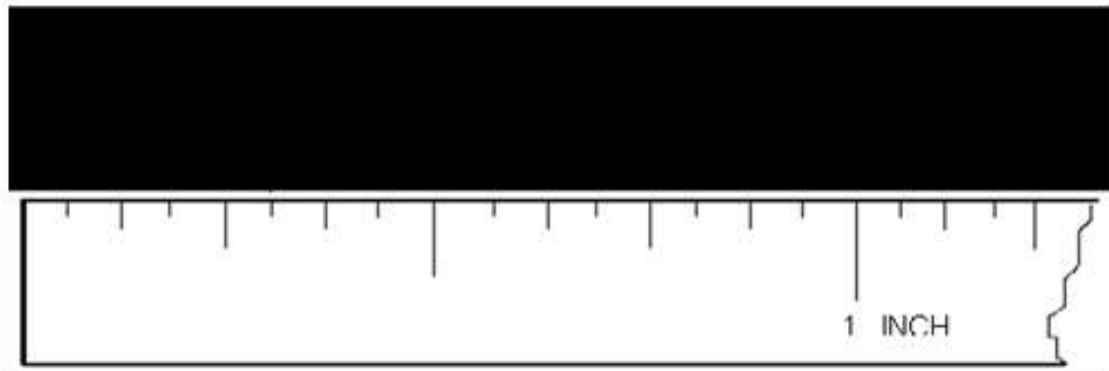

B. Metric System

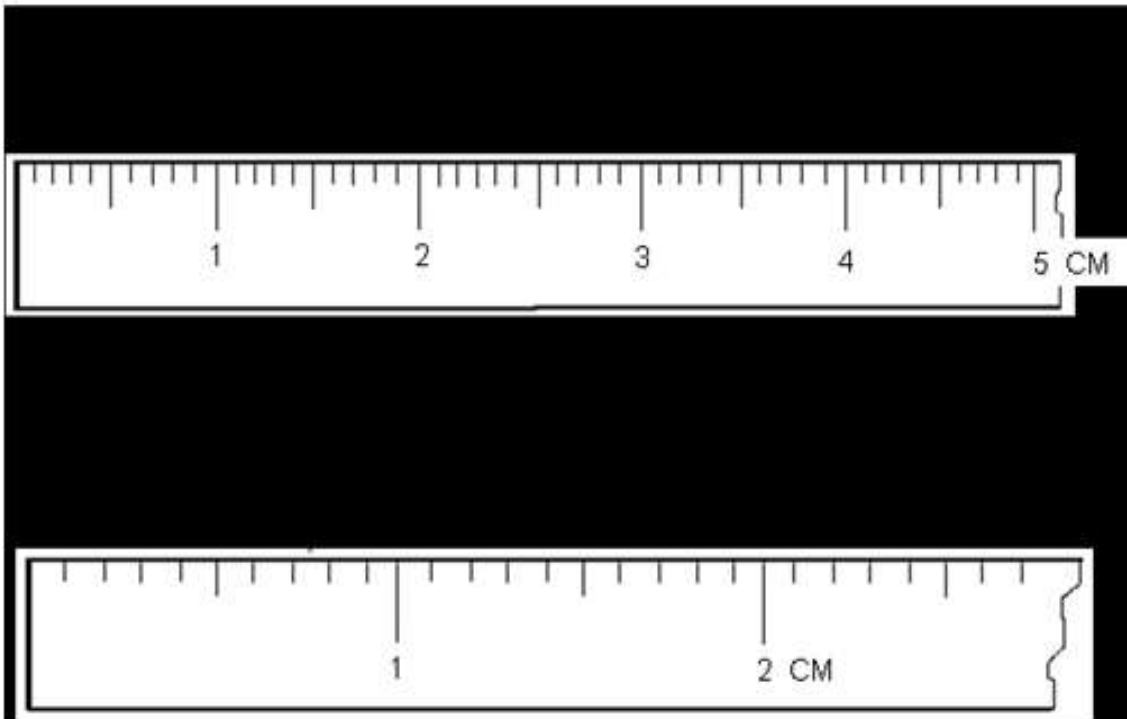

II. **Conversion:** Convert the following measurement from metric to English system or vice versa.

1. 60 cm = _____ in.

2. 3 ½ in. = _____ cm.

3. 75 cm. = _____ m.

4. 10 in. = _____ cm.

5. 30 cm = _____ ft.

Refer to the Answer Key. What is your score?



Congratulations!
You did a great job! Rest and relax a while then move on to the next lesson. Good luck!

REFERENCES

LO1

Giesecke, Mitchell and Spencer. Technical Drawing; The Macmillan Company: 1999.

French and Vierck. Engineering Drawing 10th edition MacGraw, Hill Book Company, 1960

German M. Manaois. Drafting 1 and 2 Phoenix Publishing:1983

Norman Stirling. Introduction to Technical Drawing Delmar Publishing: 1977

Competency Based Learning Material, Civil Technology

Competency Based Learning Material, Drafting Technology

<http://images.search.yahoo.com/search/image>

http://www.ehow.com/how_4880813_use-drafting-tools.html

LO 2

German M. Manaois. Drafting 1 and 2 Phoenix Publishing:1983

Norman Stirling. Introduction to Technical Drawing Delmar Publishing: 1977

Spence/Atkins. Technical Drafting : Metric Design and Computation, National Bookstore, Inc.

Competency Based Learning Material, Drafting Technology

Competency Based Learning Material, Machine Shop

LO 3

German M. Manaois. Drafting 1 and 2 Phoenix Publishing:1983

Norman Stirling. Introduction to Technical Drawing Delmar Publishing: 1977

Spence/Atkins. Technical Drafting : Metric Design and Computation, National Bookstore, Inc.

Competency Based Learning Material, Drafting Technology

Competency Based Learning Material, Machine Shop

LO 4

German M. Manaois. Drafting 1 and 2 Phoenix Publishing:1983

Spence/Atkins. Technical Drafting : Metric Design and Computation, National Bookstore, Inc.

Competency Based Learning Material, Drafting Technology

Competency Based Learning Material, Machine Shop

LESSON 3

Interpret Working Plan and Sketches

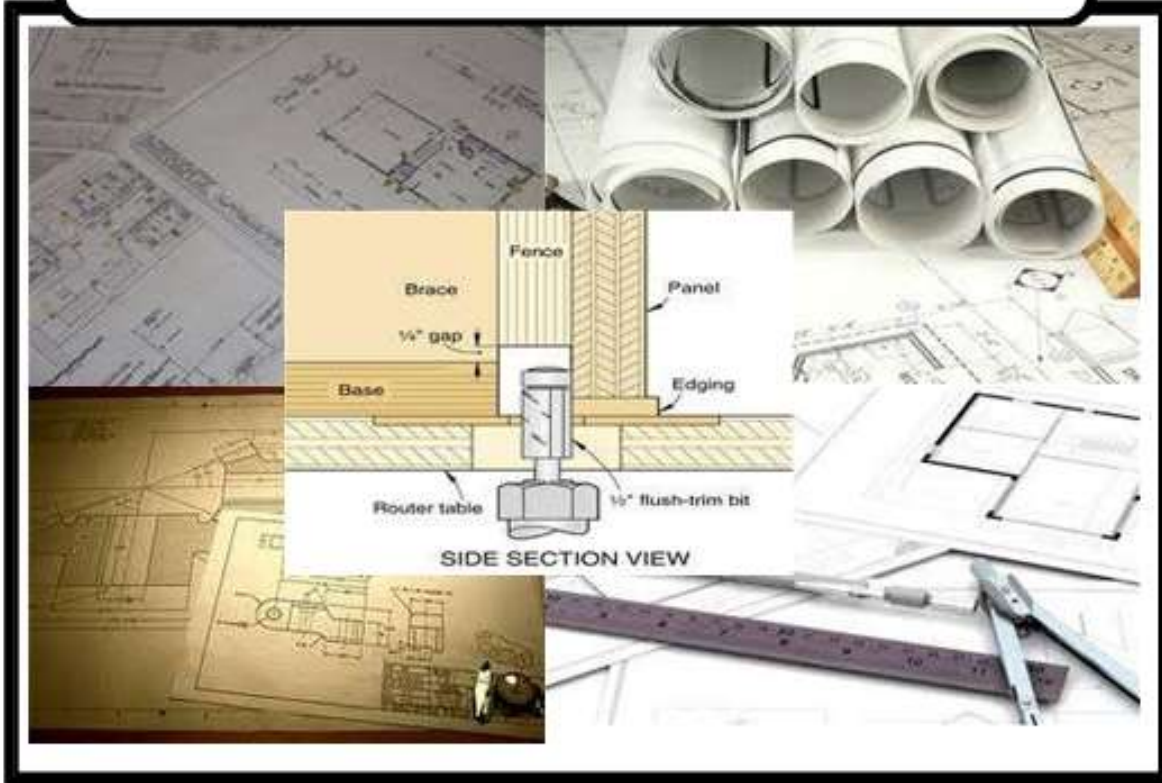

LEARNING OUTCOMES:

At the end of this Lesson, you are expected to do the following:

LO 1. identify assembly and detailed drawing



Definition of Terms

Axonometric - method of projection in which an object is drawn with its horizontal and vertical axes to scale but with its curved lines and diagonals distorted

Detailed drawing - drawing of a detail part usually in orthographic projection

Detail dimension - measurements of the detail part or parts of the object

Dimensioning - process of placing measurements in a drawing in the Metric or English System

Isometric axes - light lines used as bases in constructing an isometric view of an object

Isometric drawing - pictorial drawing showing the three views of the object tilted 30 degrees in front of the observer

Multi-view drawing - drawing that shows more than one view of an object

Notation - all lettering and other dimension found in a drawing or working sketch

Oblique drawing - kind of pictorial drawing of an object one surface of which is shown parallel to the frontal plane and the other is inclined to it

Orthographic projection - presentation of an object in two or more views by projecting the outline of the object to the plane of projection perpendicular to each other

Overall dimension - the total width, height and depth of the object

Perspective drawing - a drawing which shows an object as it appears to our eyes

Pictorial view - the presentation of an object where it is viewed showing the three faces of an object

Working plan - a freehand drawing showing all the information needed to construct an object

LEARNING OUTCOME 1

Identify assembly and detailed drawing

PERFORMANCE STANDARDS

1. Orthographic and pictorial drawings are interpreted according to drawing standard.
2. Assembly and detailed drawing are interpreted according to drawing standard.



Materials

- T- square
- Triangles 30 x 60 and 45 x 45
- Pencils/ mechanical pencils
- Compass
- Drawing paper
- Drawing board
- Scale
- Eraser
- Erasing shield
- Protractor



What Do You Already Know?

Let us determine how much you already know about the assembly and detailed drawing. Take this test.

Pretest LO 3

A. Directions: Read the statement carefully. Select the correct answer and write the letter of your answer on a separate sheet of paper.

1. The system for graphically representing an object by line drawing on a flat surface.

- | | |
|----------------------------|----------------------|
| A. Orthographic Projection | B. Pictorial Drawing |
| C. Multi-view Drawing | D. Isometric Drawing |

2. Angles of projection generally used for drafting purposes are.

- | | |
|--|-------------------------------------|
| A. Ninety degrees and Forty Five Degrees | B. First Angle and Third Angle |
| C. Second Angle and Fourth Angle | D. Thirty Degrees and Sixty Degrees |

3. Standard projection used by many European countries (ISO Standard).

- | | |
|----------------------------|---------------------------|
| A. Orthographic Projection | B. Third-angle Projection |
| C. Isometric Projection | D. First-angle Projection |

4. The common views used in multi-view drawing are _____.

- | | |
|--------------------------|--------------------------|
| A. front, top, and sides | B. front, rear and sides |
| C. front, sides and rear | D. front, top and rear |

5. Type of dimensioning that requires all dimension figures be lettered between guide lines that are parallel to the bottom edge of the drawing paper.

- | | |
|----------------------|---------------------------|
| A. Aligned Method | B. Location Dimension |
| C. Overall Dimension | D. Uni-directional Method |

6. The orthographic view drawn directly above the front view.

- | | |
|--------------------|-------------------|
| A. Auxiliary view | B. Top View |
| C. Right side view | D. Left Side View |

7. Standard of projection used by Americans, British and Canadians (ANSI Standard).
- A. First-angle Projection
 - B. Orthographic Projection
 - C. Diametric Projection
 - D. Third-angle Projection
8. A line used to show the limits of a dimension.
- A. Extension line
 - B. Object line
 - C. Dimension line
 - D. Center line
9. An oblique drawing in which the depth axis lines are in full size.
- A. Cabinet Oblique
 - B. Cavalier Oblique
 - C. General Oblique
 - D. Oblique Perspective
10. In a scale 1: 20 meters, 5 meters is equivalent to:
- A. 20 cm.
 - B. 15 cm.
 - C. 5 cm.
 - D. 10 cm.
11. This is the type of oblique pictorial view where the dimension of the receding features of the object is drawn half-scale.
- A. Cabinet Projection
 - B. Cavalier Projection
 - C. Isometric Projection
 - D. Orthographic Projection
12. The point where the horizontal line in the perspective view seems to converge or meet.
- A. Station Point
 - B. Vanishing Point
 - C. Center Point
 - D. Piercing Point
13. Type of dimensioning that requires all dimension figures, except to angular contours, be lettered between guide lines that are parallel to the dimension lines.
- A. Aligned Method
 - B. Location Dimension
 - C. Overall Dimension
 - D. Uni-directional Method
14. The process of describing the object by placing sizes and related information on a drawing.
- A. Dimensioning
 - B. Sectioning
 - B. Scaling
 - D. Tolerancing
15. This is the dimension that gives the detail and overall sizes of the object.
- A. Location dimension
 - B. Figure Dimension
 - C. Shape dimension
 - D. Size Dimension

B. Directions: Write the names of the kind of lines indicated by numbers 1 to 10. Place your answer on a separate sheet of paper.

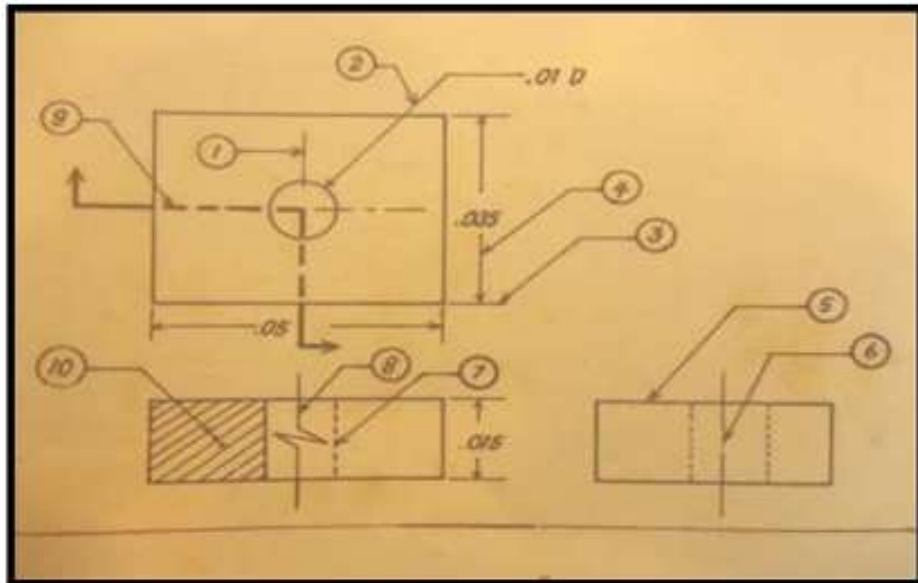

C. Directions: Base on your answer on the drawing above, write the name of the view where you find the different kind of lines listed below.

<u>Kind of Lines</u>	-	<u>Name of Views</u>
1. Center line	-	Right-side view
2. Long-break line	-	Front view
3. Cutting-plane line	-	Top view
4. Leader line	-	Top view
5. Section line	-	Front view

Compare your answers using the Answer Key. If you got 90-100% of the items correct, that means you are already familiar with the lesson covered by Learning Outcome No. 1. Therefore you can proceed to the next learning activity . If you missed a lot of items, do all the activities again to gain knowledge and skills required for mastery.



What Do You Need To Know?

Read the Information Sheet very well then find out how much you can remember and how much you learned by doing Self-check 1.1.

Information Sheet 1.1

A drawing is made up of different lines. Each line represents something. A surface, a hidden surface, an extension of a surface, a center of a hole, or a line with dimension on it. In order to make the drawing easier to read and understand, each kind of line is drawn with a different line weights. Read and understand the following.

ALPHABET OF LINES

Visible line - a thick line that represents the visible edges or outline of the object; also known as the object line

Hidden line - a medium thick line composed of short dashes about 2-3 millimeters long with space between dashes about 1-2 millimeters wide; it represents the surface or edges that cannot be seen

Center line - a thin line consisting of two long dashes and short dash drawn alternately with a gap of at least 2 millimeters in between; it represents the axis or center of symmetrical shapes like a ball, washer, rectangular block, cube

Section line - a thin lines to show the surface that has been cut; they are spaced evenly at 45 degrees with the horizontal to make shaded effect

Extension line - a thin line that extends from the object in order to show dimension limits

Dimension line - a thin line with an arrowhead in one end used to indicate the measurements of the object

Long-break line - a medium thick line consisting of broken and straight lines drawn alternately. This is also known as the limiting line. This limits the length of an elongated object without changing the size of its view.

Short-break line - thick line drawn in freehand to show details that a part has been cut off or broken out.

Leader line - a short inclined thin line with an arrowhead at the end and short horizontal line on the other end.

Phantom line - a thin line that shows position(s) of part of an object that moves drawn by two short dashes and one long dash.

Cutting-plane line -thick lines used to indicate an imaginary cut through an object along the line. Made up of two long dashes broken in one end with an arrowhead and two short dashes drawn in between the long dashes.

Lines	Width and Character of Lines	Applications
Visible line	THICK Width 0.75 - 0.96 mm (.030 - .038")	
Hidden line	THIN Width 0.38 - 0.55 mm (.015 - .022") 0.8 mm (.031") 3.2 mm (.125")	
Section line	THIN Width 0.38 - 0.55 mm (.015 - .022")	
Center line	THIN Width 0.38 - 0.55 mm (.015 - .022") 19 - 38 mm (.75 - 1.50") 3.2 mm (.125") 1.6 mm (.062")	
Dimension line, Extension line, Leaders	THIN Width 0.38 - 0.55 mm (.015 - .022") 90.5	
Cutting-plane or Viewing-plane lines	THICK Width 0.75 - 0.96 mm (.030 - .038") THIN Width 0.38 - 0.55 mm (.015 - .022") 1.6 mm (.062") 3.2 mm (.125") 19 - 38 mm (.75 - 1.50") 6.4 mm (.25")	
Short-break line	THICK Width 0.75 - 0.96 mm (.030 - .038") Freehand	
Long-break line	THIN Width 0.38 - 0.55 mm (.015 - .022") 19 - 38 mm (.75 - 1.50") Freehand	
Phantom line	THIN Width 0.38 - 0.55 mm (.015 - .022") 1.6 mm (.062") 19 - 38 mm (.75 - 1.50") 1.6 mm (.062")	



How Much Have You Learned?

Self-Check 1.1

Directions: Read and interpret the given figure below. Identify the lettered lines used (A - N) to draw the object. Place your answer on a separate sheet of paper.

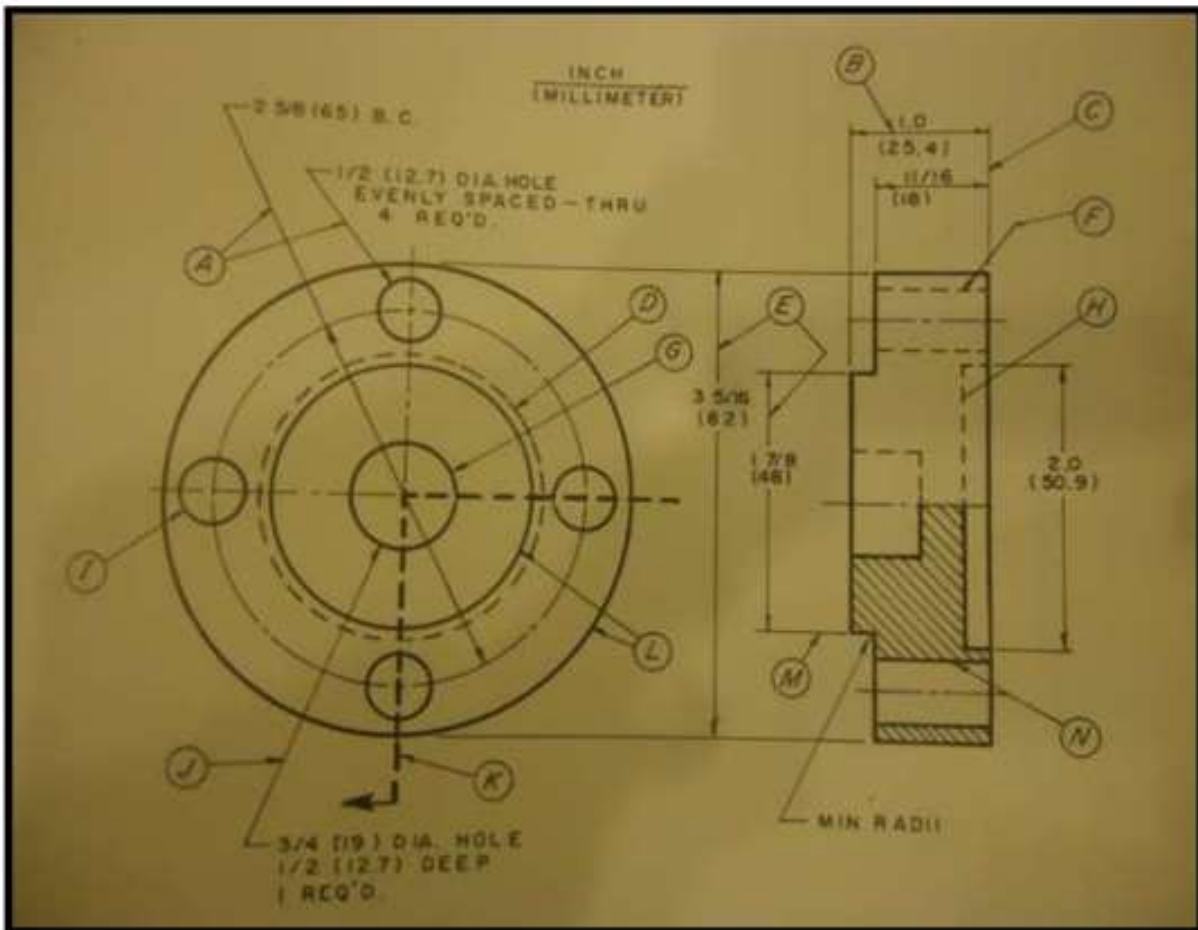

- A. _____
- B. _____
- C. _____
- D. _____
- E. _____
- F. _____
- G. _____

- H. _____
- I. _____
- J. _____
- K. _____
- M. _____
- N. _____

Refer to the Answer Key. What is your score?



How Do You Apply What You Have Learned?

Show that you learned something by doing this activity

Activity Sheet 1.1

Directions: Sketch the line being referred to in the Table below. Place your answer on a separate sheet of paper.

Kind of Lines	Sketch of the Lines
Short-break line	
Center line	
Extension line Dimension line Leader line	
Phantom line	
Section line	
Hidden line	
Long-break line	
Cutting-plane line or Viewing-plane line	
Visible line	



How Well Did You Perform?

Find out by accomplishing the Scoring Rubric honestly and sincerely.
Remember it is your learning at stake!

Criteria for Assessment: Analytic Scoring Rubrics

Criteria	5 points	3 points	1 point
Accuracy	All lines are drawn appropriately according to its characteristics	There are 1 to 3 lines inappropriately drawn according to its characteristics	Majority of the lines are inappropriately drawn
Neatness	Finished output was neatly done, pleasing, and no erasures/smudges	Pleasing but erasures and smudges are observable on the finished output	Finished output have so many erasures and smudges
Time Management	Finished the task 5 minutes before the given time	Finished the task on time	Unable to finished the given task

Rating Scale:

Points Earned	Numerical	Descriptive
12 - 15	91 - 100	Very Good
8 - 11	86 - 90	Good
4 - 7	81 - 85	Fair
1 - 3	75 - 80	Needs Improvement

Remarks:



What Do You Need To Know?

Read the Information Sheet very well then find out how much you can remember and how much you learned by doing Self-check 1.2.

Information Sheet 1.2

An artist's drawing is generally called freehand drawing that is, drawings are made without the use of drawing instruments or straightedges. Freehand drawing is synonymous to *sketching*. This technique is necessary in any area of drafting and an important skills for everyone. Skills in freehand drawing can be achieved through constant training and correct practice.

Line Sketching

One advantage of freehand sketching is that it needs only patience and continuous correct practice.

Basic Line Sketching

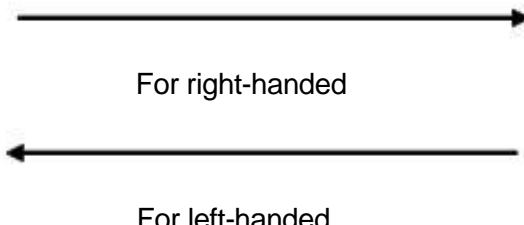
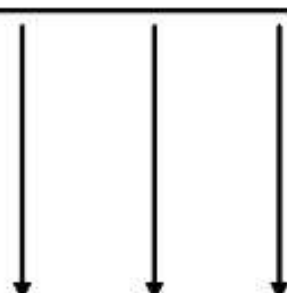
Kind of lines	Direction of strokes
 <p>Horizontal lines</p>	Strokes are drawn from left to right for right-handed and from right to left for left-handed individuals.
 <p>Vertical lines</p>	Strokes are drawn downward.

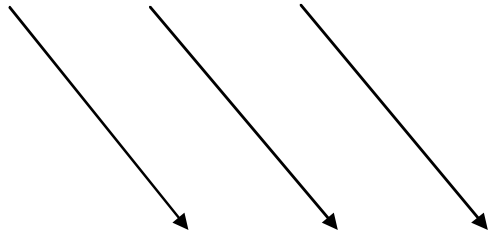

Inclined to the right

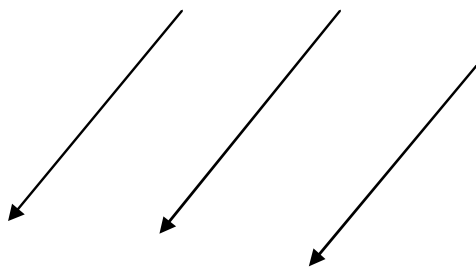

Inclined to the left

Inclined strokes (diagonal) are drawn downward

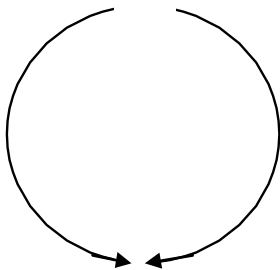

Curved line

Curved strokes are drawn downward for either right-handed or left-handed







How Much Have You Learned?

Self-Check 1.2

Directions: Using a separate sheet of paper, sketch the following lines indicated in each box.

Lines should be drawn freehand.

 <p>Vertical line</p>	 <p>Horizontal line</p>
 <p>Inclined to the left</p>	 <p>Inclined to the right</p>

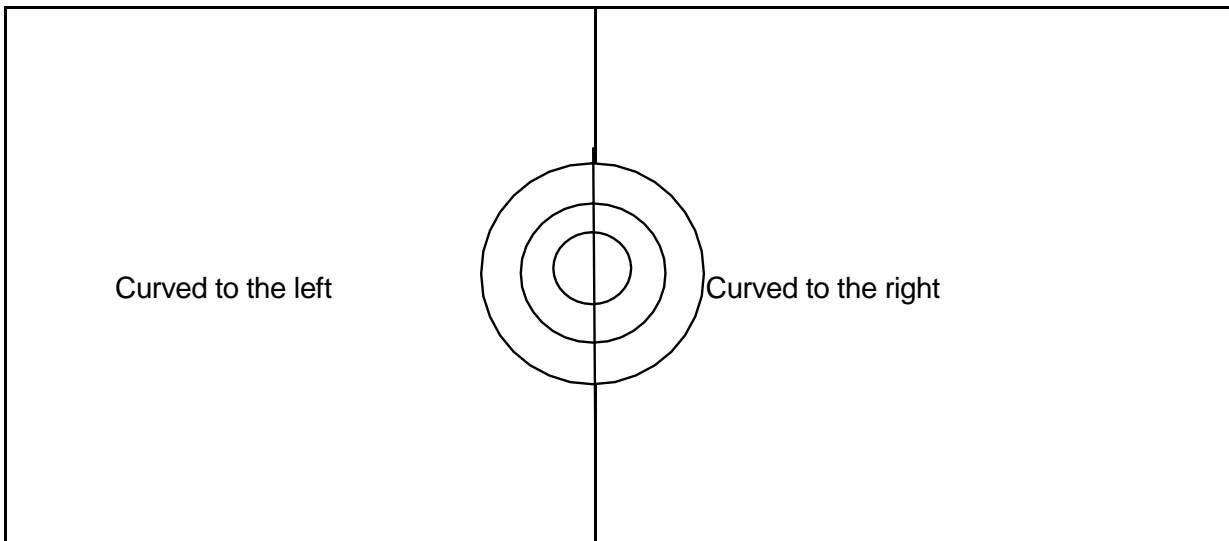

Refer to the Answer Key. What is your score?



How Do You Apply What You Have Learned?

Show that you learned something by doing this activity

Operation Sheet 1.2

Directions: Below is a suggested activity on line exercises. Choose at least twelve (12) from the given examples on line sketching. Observe accuracy. Place your drawings in a separate sheet of paper.

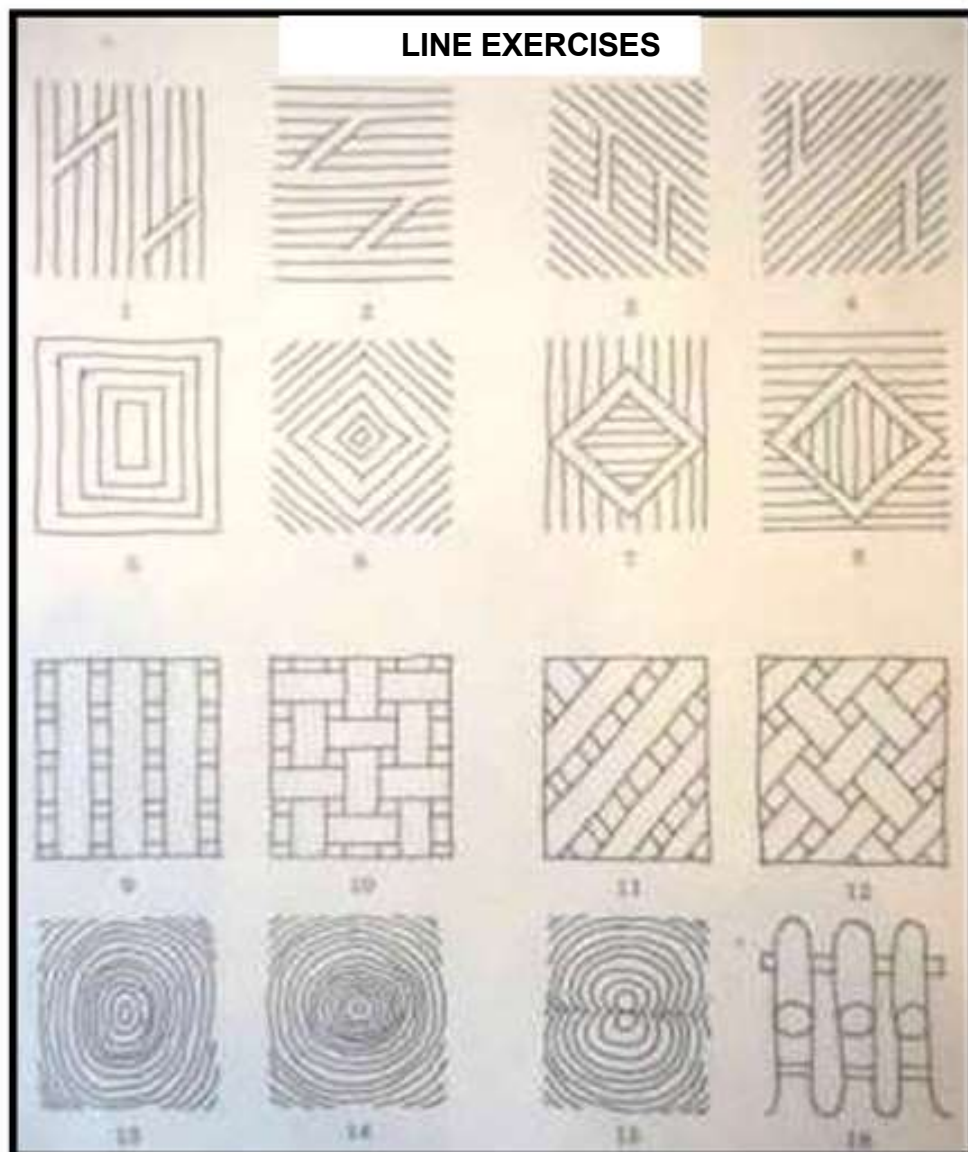



How Well Did You Perform?

Find out by accomplishing the Scoring Rubrics honestly and sincerely.
Remember it is your learning at stake!

Criteria for Assessment: Analytic Scoring Rubrics

Criteria	5 points	3 points	1 point
Accuracy	All lines are drawn appropriately and freehand	Some lines are drawn inappropriately and NOT in freehand	Most of the lines are inappropriately drawn and NOT in freehand
Neatness	Finished output was neatly done, pleasing, and no erasures/smudges	Pleasing but erasures and smudges are observable on the finished output	Finished output have so many erasures and smudges and quite unpleasant
Time Management	Finished the task 10 minutes before the given time	Finished the task on time	Unable to finished the given task

Rating Scale:

Points Earned	Numerical	Descriptive
12 - 15	91 - 100	Very Good
8 - 11	86 - 90	Good
4 - 7	81 - 85	Fair
1- 3	75 - 80	Needs Improvement

Remarks:

How did you find this activity? Did you enjoy answering it? Is it hard? Challenge yourself by keep on trying to finish this activity. Be patient. Have self confident.



What Do You Need To Know?

Read the Information Sheet very well then find out how much you can remember and how much you learned by doing Self-check 1.3.

Information Sheet 1.3

THEORIES AND PRINCIPLES OF ORTHOGRAPHIC PROJECTION

Multi-view drawing - a drawing that shows more than one view of an object.

Orthographic Projection - A system for graphical representation of an object by a line drawing on a flat surface.

Orthographic View - a drawing that shows a side of an object viewed directly from 90 degrees.

Six (6) Principal Views of an Object:

The simple work piece below shows the six (6) principal sides or views.

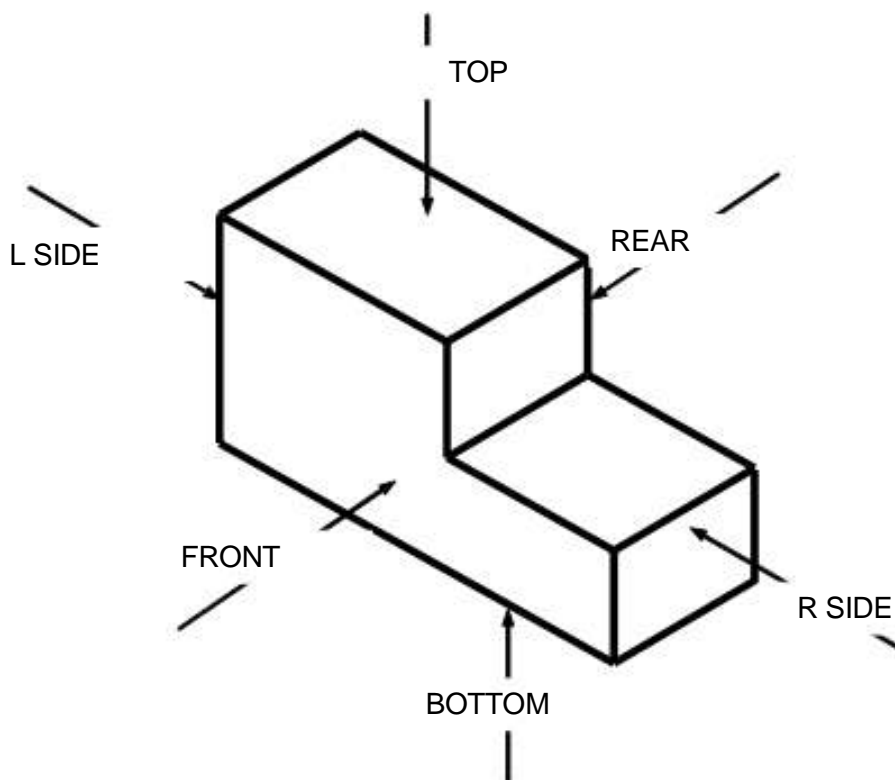

An orthographic view is made by projecting the edge of the object perpendicular to a plane of projection.

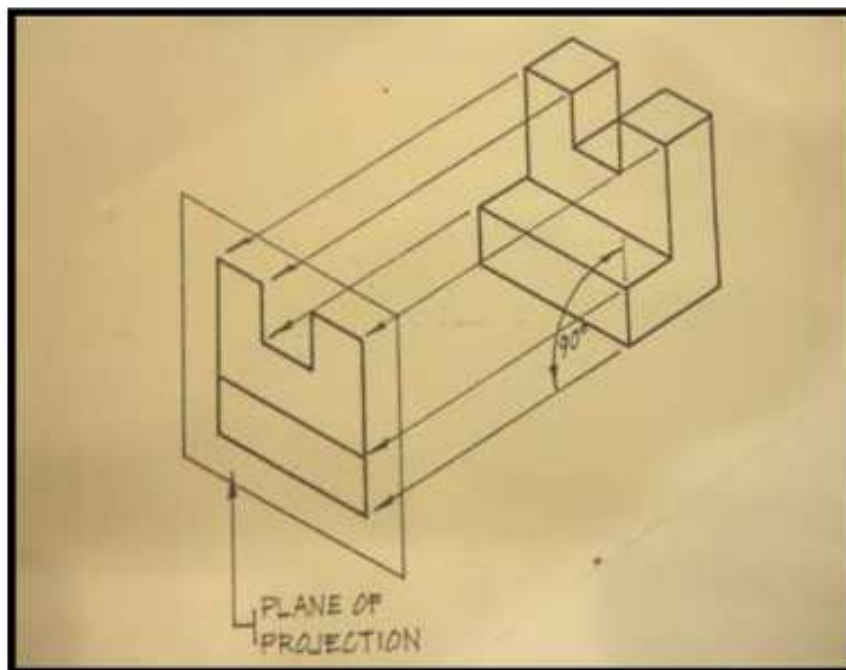

Planes of Projection

Three planes of projection are used in orthographic drawing. These are called the horizontal plane, frontal plane, and the profile plane.

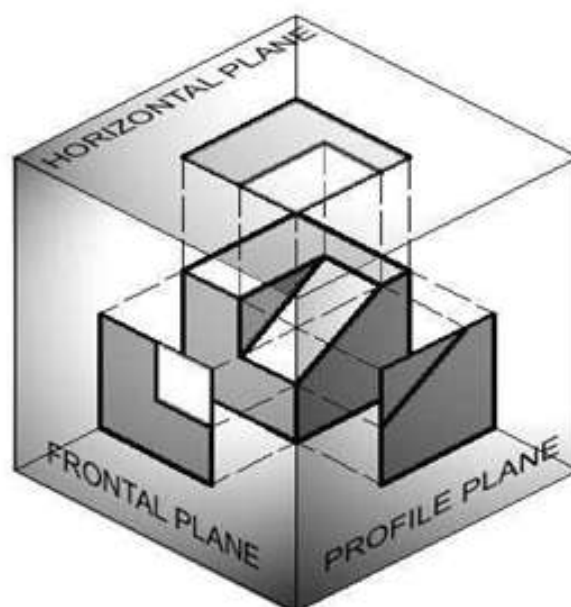

The planes of projection join and form quadrants. The quadrants are called first angle, second angle, third angle, and fourth angle. The first and the third quadrants are used for drafting purposes.

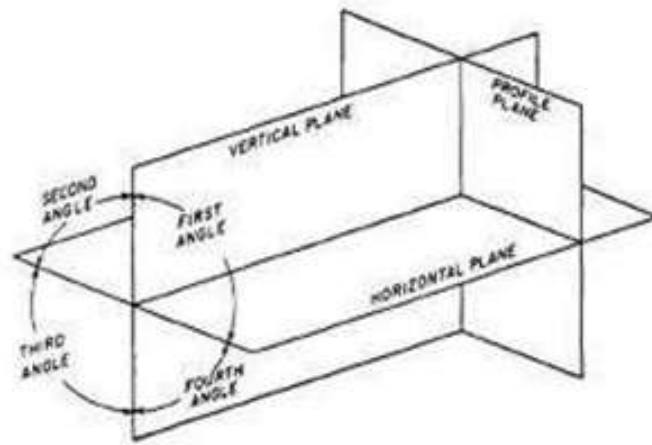

Overall Size of the Object

1. Height is the perpendicular distance between two horizontal planes.

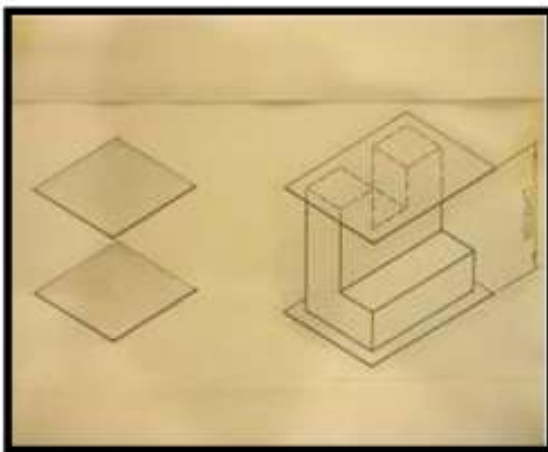

HEIGHT

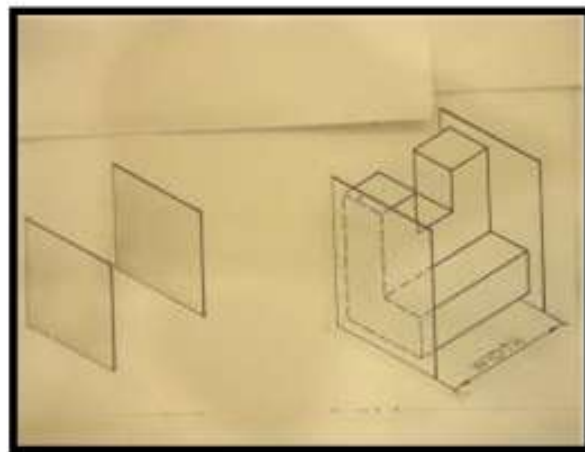

WIDTH

2. Width is the perpendicular distance between two profile planes.
3. Depth is the perpendicular distance between two frontal planes.

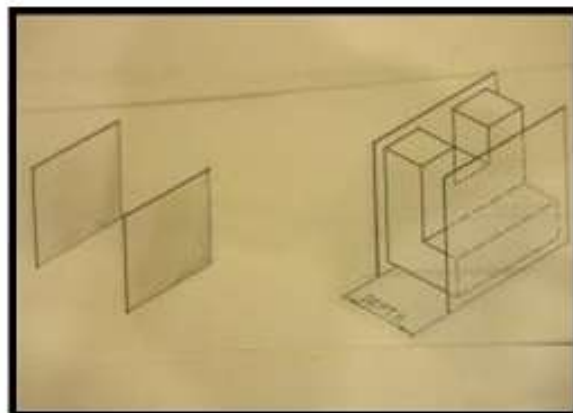

DEPTH



How Much Have You Learned?

Self-Check 1.3

Refer to the Answer Key. What is your score?

Directions: Supply the correct information on each blank.

1. The a system of orthographic projection that places the object on the first quadrant is called _____.
2. Located below the top view is the _____ of the Third angle projection.
3. The a system of orthographic projection that places the object on the third quadrant is called _____.
4. Located below the first is the _____ of the first-angle projection.
5. The perpendicular distance between horizontal planes is referred to as _____.
6. The perpendicular distance between profile planes is called _____.
7. The perpendicular distance between frontal planes is called _____.



What Do You Need To Know?

Read the Information Sheet very well then find out how much you can remember and how much you learned by doing Self-check 1.4.

Information Sheet 1.4

Mechanical drawing is describing the shapes of objects completely and exactly by the use of orthographic views. Although there are six principal views that can be drawn in an object, only the three regular views are normally required in the preparation of a working plan.

ORTHOGRAPHIC PROJECTIONS

1. First-Angle Projection (ISO Standard)

The first-angle projection is a system of orthographic projection used by the European countries which places the object on the first quadrants.

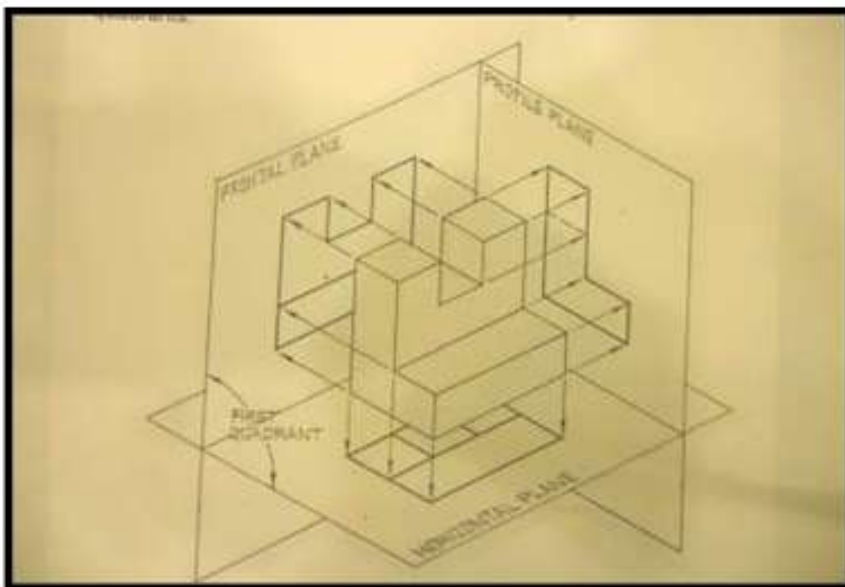

Here the horizontal plane is below the object.

- The top of the object is projected down the horizontal plane.
- The rear projects to the frontal plane.

Unfolded Planes

With the planes unfolded and laid flat, the front view is above the top view.

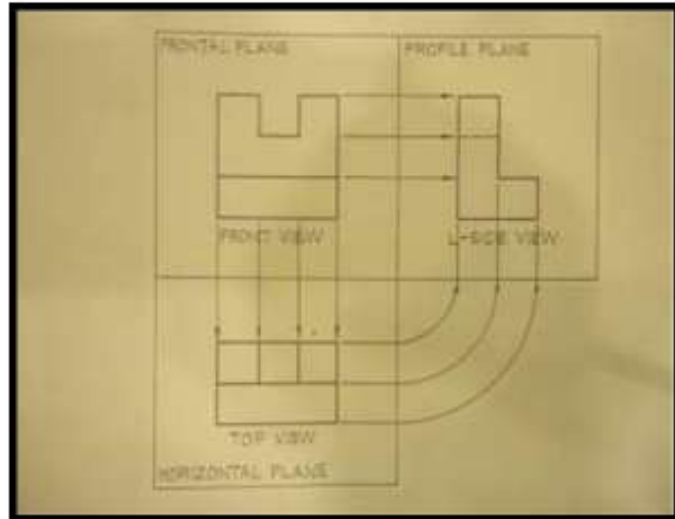

The position of the unfolded planes in the first-angle projection

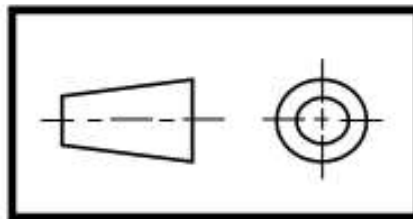

SYMBOL USED FOR FIRST ANGLE

2. Third-angle Projection (ANSI)

The third-angle projection is a system used in the United States which places the object in the third quadrants.

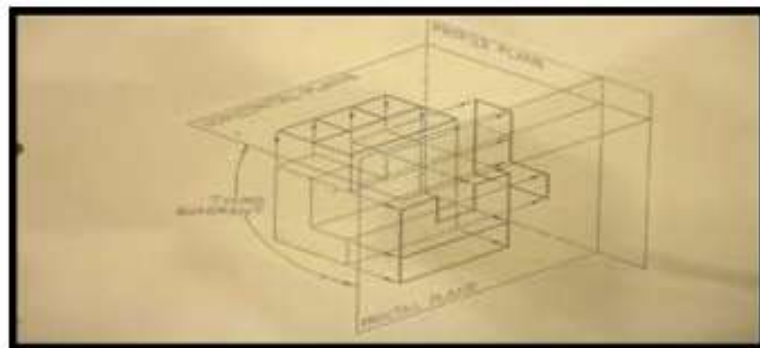

The third-angle projection places the object in the third quadrant. (An observer here would be facing the frontal plane).

- Observe that the object is placed below the horizontal plane.
- The top view of the object projects up to it, therefore, the top view is in the horizontal plane.
- The object is behind the frontal plane. The front view of the object projects forward to it, therefore, the view is on the frontal plane.
- The side of the object projects to the profile plane, therefore, the side view will be seen in the profile plane.

Unfolded Planes

If the planes be unfolded and laid flat, the top view would be above the front view.

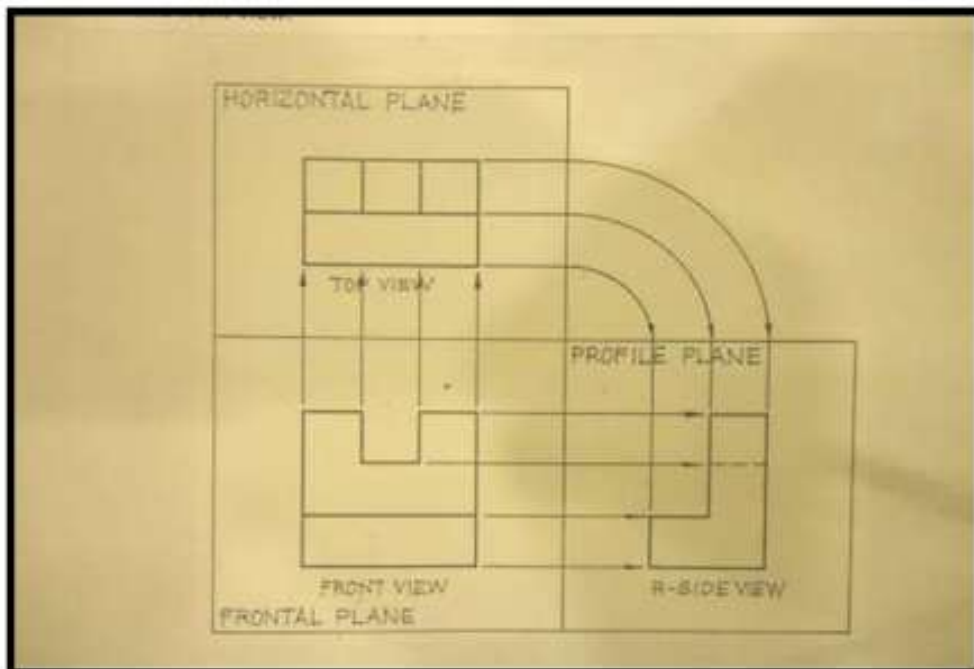

The position of the unfolded planes in the third-angle projection

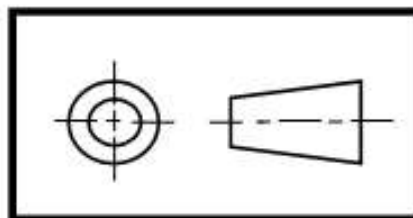

SYMBOL USED FOR THIRD ANGLE



How Much Have You Learned?

Self-Check 1.4

Direction: You have just finished the study of the basic principles of orthographic projection. To ensure understanding, try your best to supply the needed information to complete the following statements.

1. The system for graphically representing the object by a line drawing on a flat surface is called _____.

When the three planes of projections joined together, they will form quadrants. They are the following: (in any order)

- 2.
- 3.
- 4.
- 5.

The quadrants used for drafting purposes are (in any order)

6. _____ and
- 7.

Orthographic view is drawn by projecting the edge of the object perpendicular to these planes of projection.

- 8.
- 9.
10. _____

Refer to the Answer Key. What is your score?



How Do You Apply What You Have Learned?

Show that you learned something by doing this activity.

Activity Sheet 1.4

Directions: Below (Fig. 1) is a simple activity for you to work on. Sketch the three regular views using the Third-angle projection. Practice the task following the given procedure

Tools and materials:

- Drawing paper or a long bond paper
- Pencil
- Eraser

Equipment:

- Drawing Table (Drafting Table or Drawing Board)

Procedure:

1. Prepare all the tools and materials needed.
2. Study the given object (Figure 1) carefully. Observe its dimensions: width, height and depth.
3. Sketch two parallel vertical projection lines representing the width of the object.
4. Draw two parallel horizontal lines projection representing the height of the object.
5. To locate the top view, measure the depth of the top then draw two horizontal parallel lines representing the top view, or if you prefer to locate the right-side view, measure the depth of the right-side then draw two parallel vertical lines representing the right-side view. To transfer the depth of the top view to the right-side view or vice versa, please refer to the accepted methods shown below.

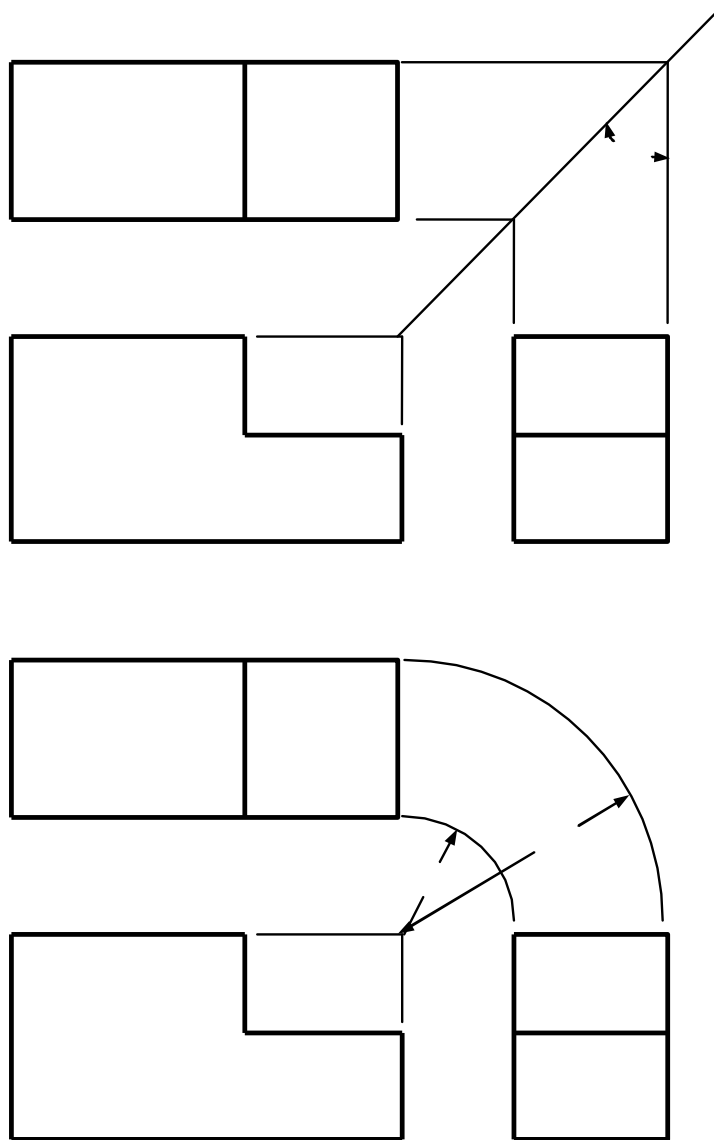

Two accepted methods used to transfer the depth of the top view to the side view.

6. Complete the drawing by applying all appropriate lines to make the object visible.
7. Erase unnecessary lines then double check your drawing.

Read the Information Sheet very well then find out how much you can remember and how much you learned by doing Self-check 1.5.

Information Sheet 1.5

PICTORIAL DRAWING

A pictorial drawing shows likeness (shape) of an object as viewed by the observer. It represents a portion of the object and shows the method of its construction. In some presentations, the whole object is shown in one view.

Types of Pictorial Drawing:

A. Axonometric Pictorial Drawing

1. Isometric drawing - a pictorial drawing showing the three surfaces of the object tilted 30 degrees in front of the observer.

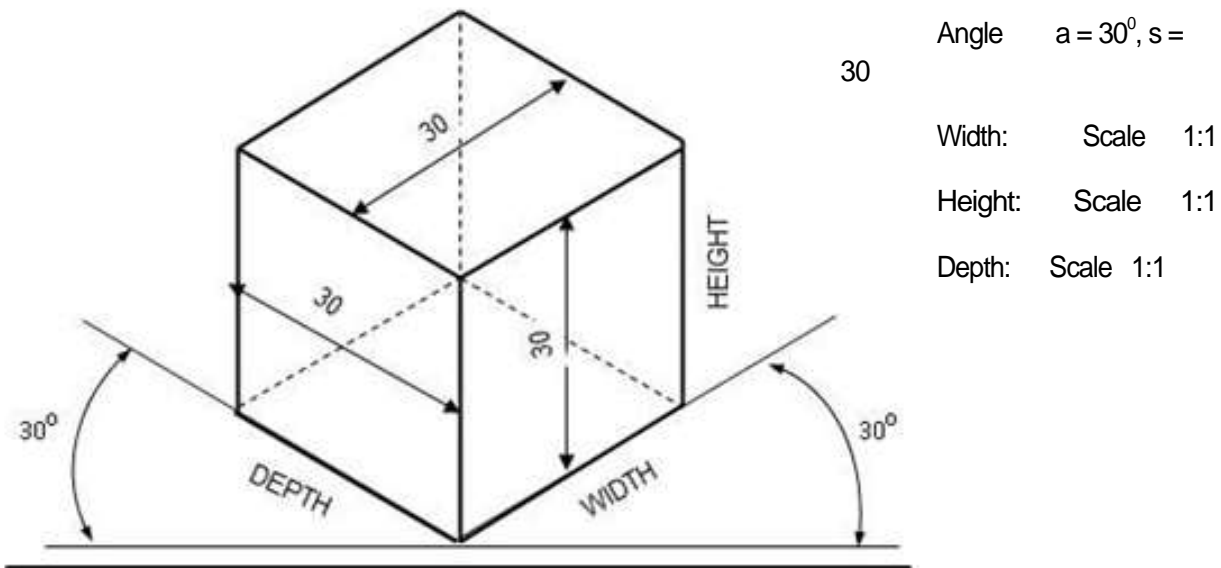

Isometric drawing according to standard

2. Dimetric drawing - the angle that is used for the horizontal planes varies according to the angle of view that has been chosen. This type is not widely used.
3. Trimetric drawing - a classification of an axonometric projection where in a cube is positioned in the way that no axes and angles are equal when projected to the plane projection.

B. Oblique Pictorial Drawing

1. Cavalier drawing - an oblique drawing in which the depth axis lines are full scale or in full size.
2. Cabinet oblique - depth axis lines are drawn one-half scale.
3. General oblique - depth axis lines vary from one-half to full size.

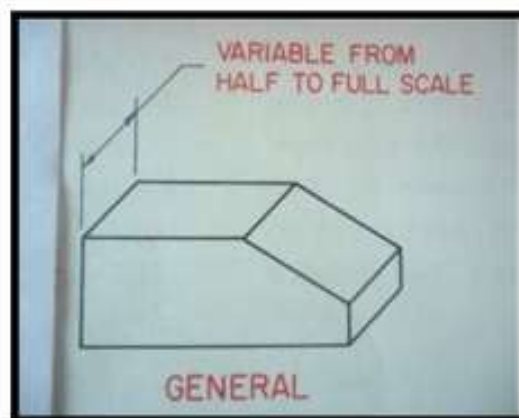
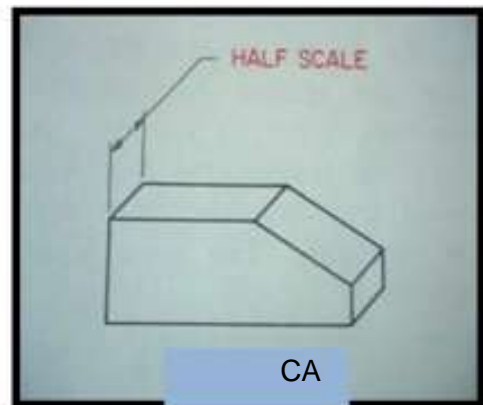
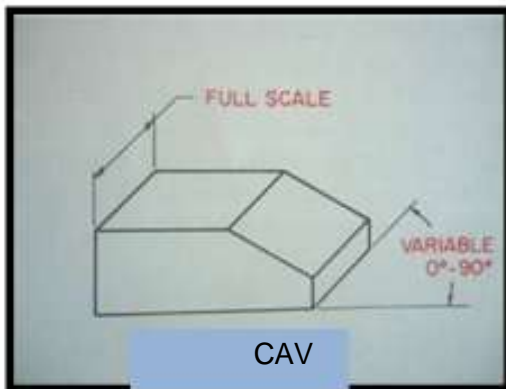

GENERAL

C. Perspective Pictorial Drawing

1. 1-pt. or Parallel perspective - a perspective drawing using one vanishing point, the front view is drawn in its true shape in full or scale size.

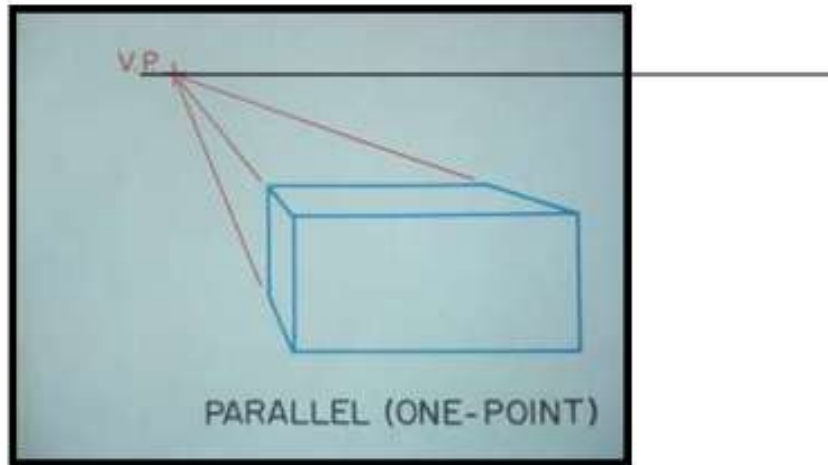

2. 2-pt. or Angular perspective - a perspective drawing using having two vanishing points.

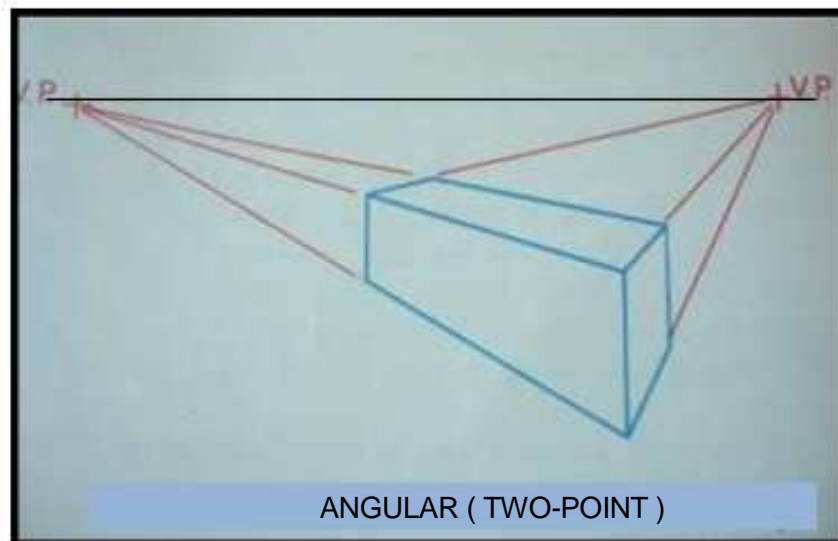

3. 3-pt. or Oblique perspective - a perspective drawing using three vanishing points.

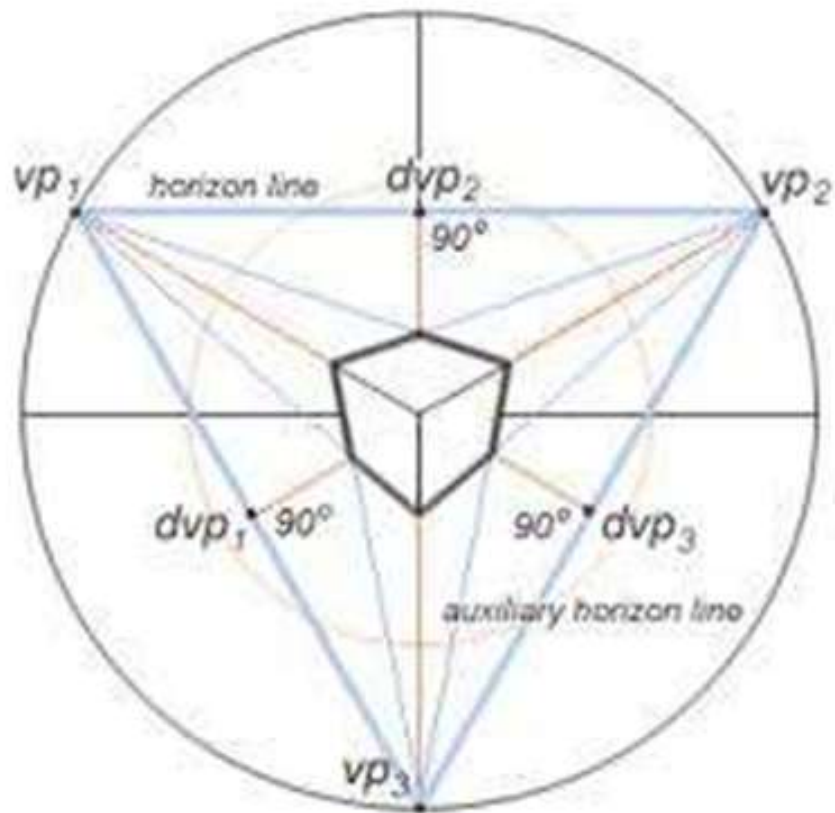



How Much Have You Learned?

Self-Check 1.5

Instructions: Supply the needed information to complete the following statements.

1. A drawing showing more than one side of an object tilted in front of the observer.
a. pictorial drawing b. artistic drawing c. multi-view drawing d. orthographic drawing
2. The place or point where the observer is supposed to stand while viewing the object.
a. vanishing point b. center point c. piercing point d. station point
3. The point where the horizontal line in the perspective view seems to converge or meet.
a. station point b. vanishing point c. center point d. piercing point
4. The object is placed on the horizon at the eye-level of the observer.
a. bird's eye view b. worm's eye view c. man's-eye view d. orthographic view
5. An oblique drawing in which the depth axis lines are in full size.
a. cabinet oblique b. cavalier oblique c. general oblique d. oblique perspective
6. Iso means equal, metric means _____.
7. Circle becomes ellipse in _____.
8. Lines that are not parallel to the three base lines in isometric are called _____.

Refer to the Answer Key. What is your score?



What Do You Need To Know?

Read the Information Sheet very well then find out how much you can remember and how much you learned by doing Self-check 1.6.

Information Sheet 1.6

Isometric Drawing

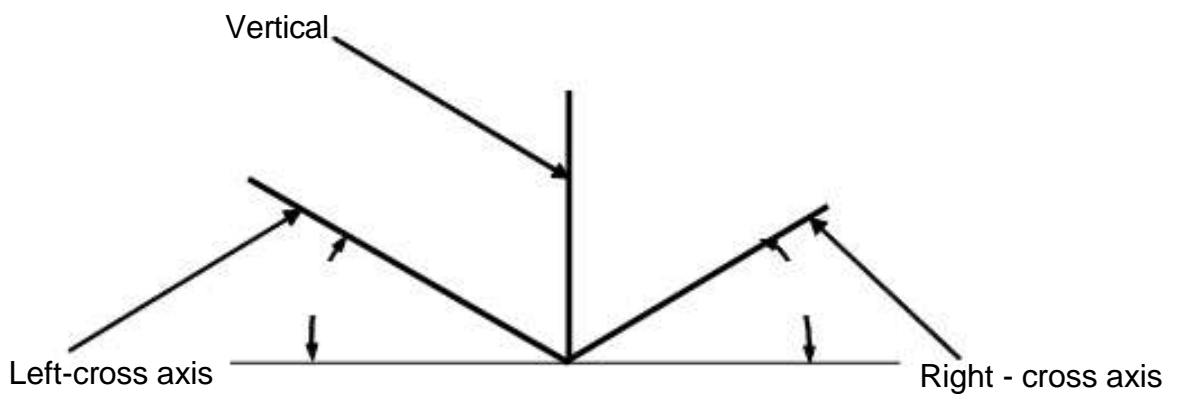
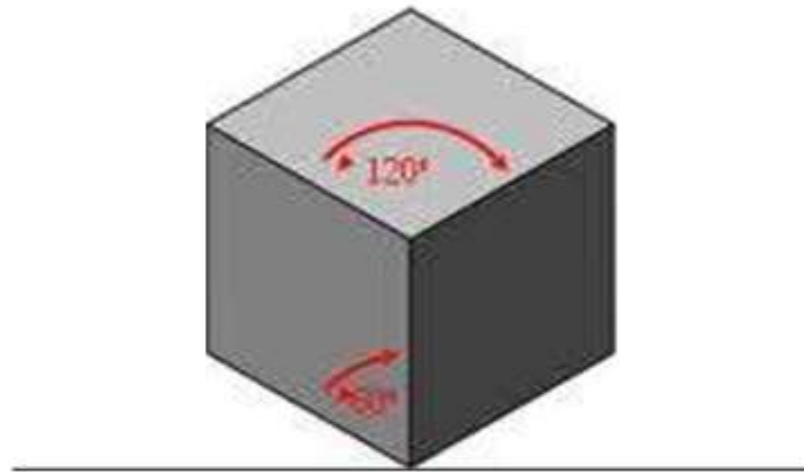

Axes used in Isometric Drawing

1. Vertical axis
2. Right-cross axis
3. Left-cross axis

Isometric drawing - a pictorial drawing showing the three surfaces of the object tilted 30 degrees in front of the observer.

Isometric lines - are lines drawn parallel to the isometric axes.

Steps in Drawing Isometric from a given Orthographic Views

1. Study the given orthographic views carefully. Estimate the width, height and the depth of the object, then sketch the axes used in isometric drawing.

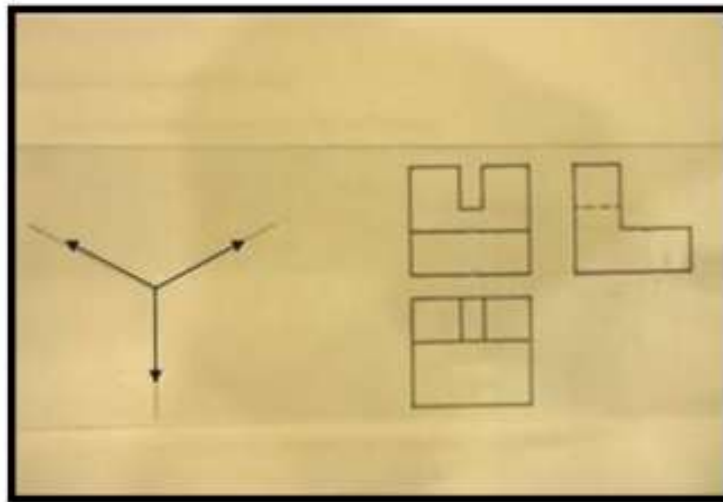

2. Transfer the height (A), the width (B), and the depth (C) of the object to the corresponding axis respectively.



Height (A)

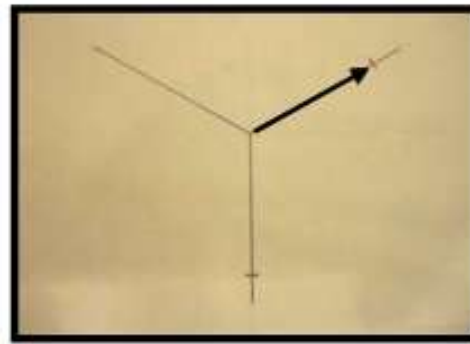

Width (B)

Depth (C)



3. Sketch isometric lines to complete the isometric box.

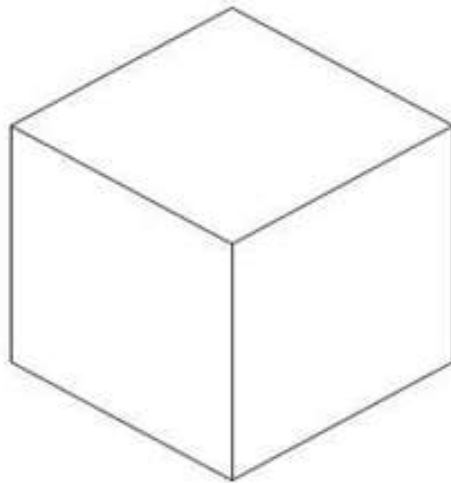

ISOMETRIC BOX

4. Layout details of the object inside the box then finish the pictorial view by drawing the object lines.

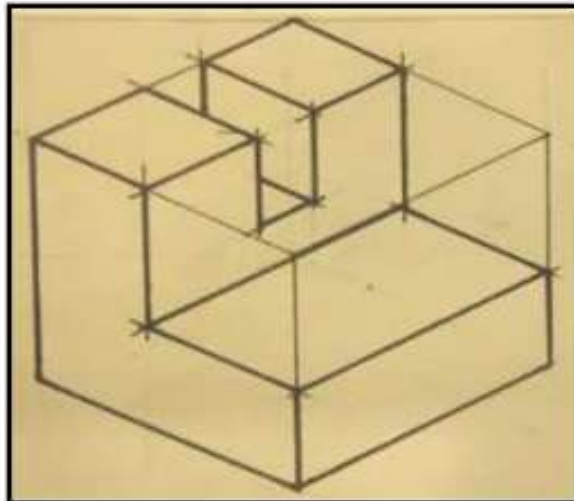

Isometric view



How Do You Apply What You Have Learned?

Show that you learned something by doing this activity.

Activity Sheet 1.5

Directions: Below is a simple activity for you to work on. Sketch the isometric pictorial of the given orthographic views. Practice the task following the given procedure.

Tools and materials:

- Drawing paper or a long bond paper
- Pencil
- Eraser

Equipment:

- Drawing Table (Drafting Table or Drawing Board)

Procedure

1. Study the given orthographic views carefully. Estimate the width, height and the depth of the object, then sketch the axes used in isometric drawing.
2. Transfer the height (A), the width (B), and the depth (C) of the object to the corresponding axis respectively.
3. Sketch isometric lines to complete the isometric box.
4. Layout details of the object inside the box then finish the pictorial view by drawing the object lines.
5. Double check your drawing then erase unnecessary lines.

Sample orthographic views

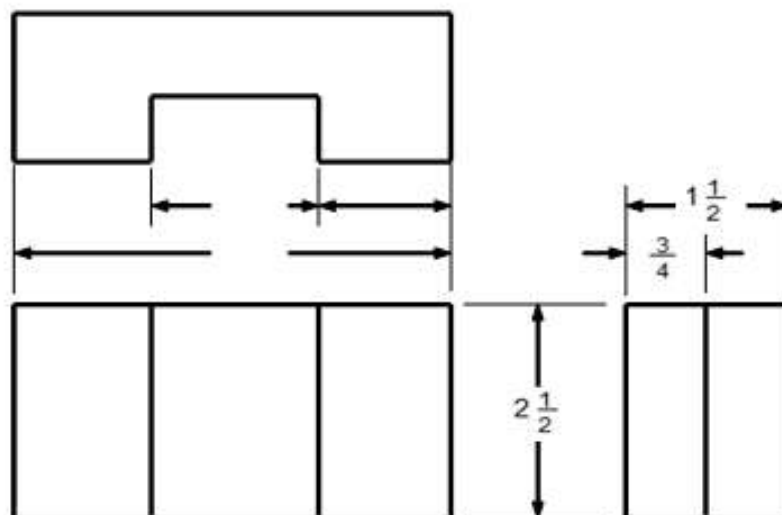



How Well Did You Perform?

Find out **by** accomplishing the Scoring Rubric honestly and sincerely.
Remember it is your learning at stake!

Criteria for Assessment:

Analytic Rubrics Scoring

Criteria	5 points	3 points	1 point
Accuracy	The isometric pictorial view was drawn according to standard	The isometric pictorial view was somehow drawn according to standard	The isometric pictorial view was NOT drawn according to standard
Neatness	Finished output was neatly done, pleasing, and no erasures/smudges	Pleasing but erasures and smudges are observable on the finished output	Finished output has so many erasures and smudges and quite unpleasant
Time Management	Finished the task 10 minutes before the given time	Finished the task on time	Unable to finished the given task

Rating Scales:

Points Earned	Numerical	Descriptive
12 - 15	91 - 100	Very Good
8 - 11	86 - 90	Good
4 - 7	81 - 85	Fair
1- 3	75 - 80	Needs Improvement

Remarks:



What Do You Need To Know?

Read the Information Sheet very well then find out how much you can remember and how much you learned by doing Self-check 1.7.

Information Sheet 1.7

More information on Oblique Drawing

Oblique drawing - the kind of pictorial drawing of an object where one surface is shown parallel to the frontal plane and the other is inclined to it.

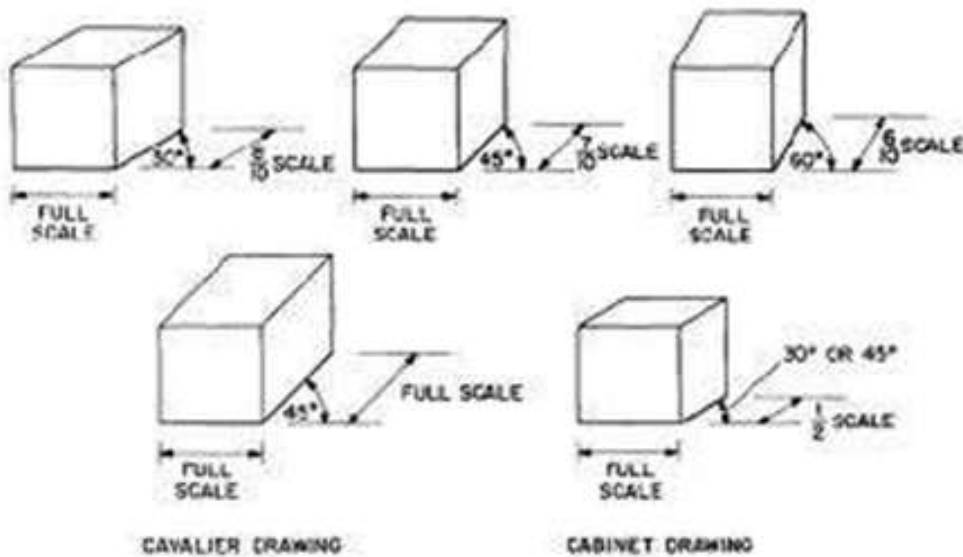

Axes in Oblique Drawing

Variations in Direction of Receding

Axis

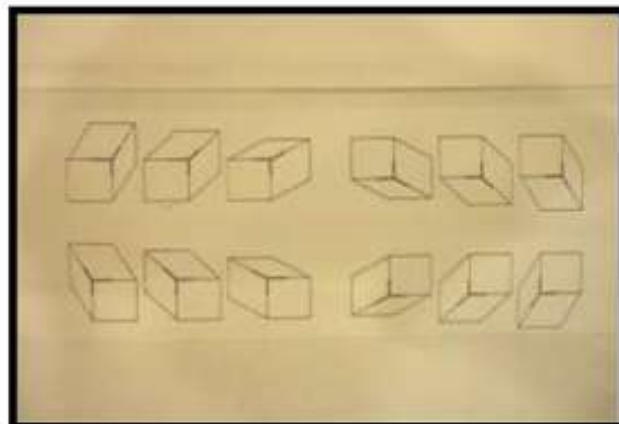
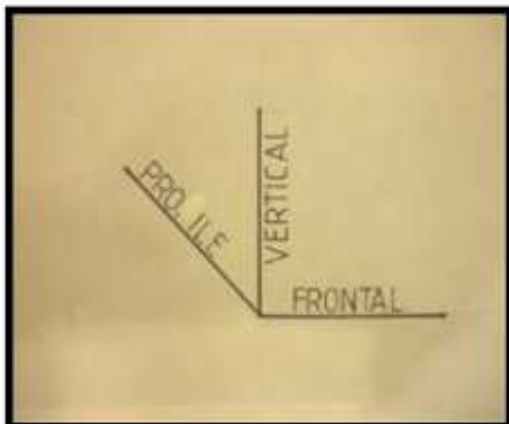

Classifications of Oblique Pictorial Drawing

1. Cavalier drawing - An oblique drawing in which the depth axis lines are in full scale or full size. The receding lines represent its true depth - it makes an angle of 45 degrees and 30 degrees with the plane of projection.

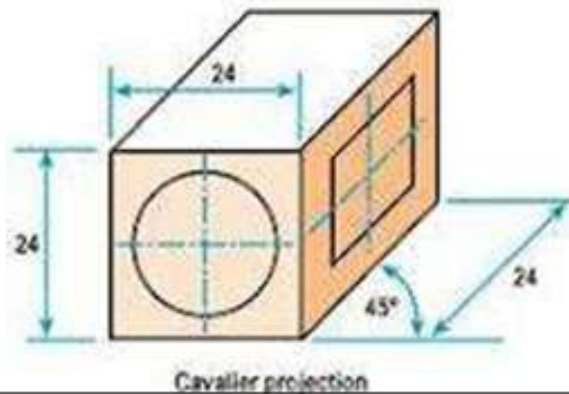

2. Cabinet oblique - Depth axis lines are drawn at one-half scale. The receding line is drawn half - size, and the projectors makes an angle of 30, 45, 60 degrees respectively.

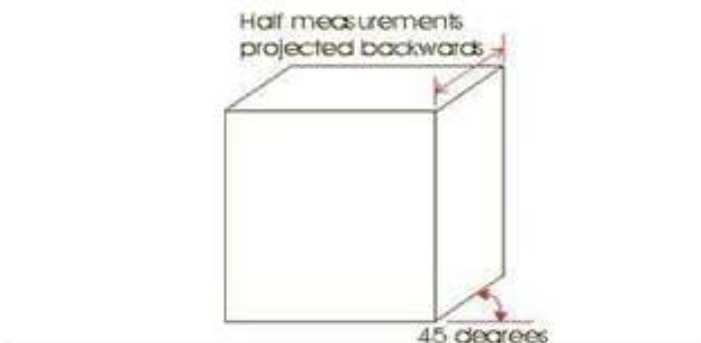

3. General oblique - Depth axis lines vary from one-half to full size. Drawn at any convenient angle and the receding lines are drawn full size, one-third size, one-half size, or one fourth-size.

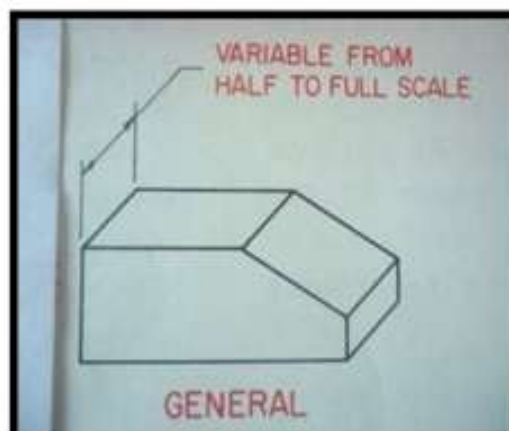

Procedure in Sketching Oblique Pictorial View

1. Study carefully the given orthographic views. Sketch the vertical line OB and horizontal line OA.

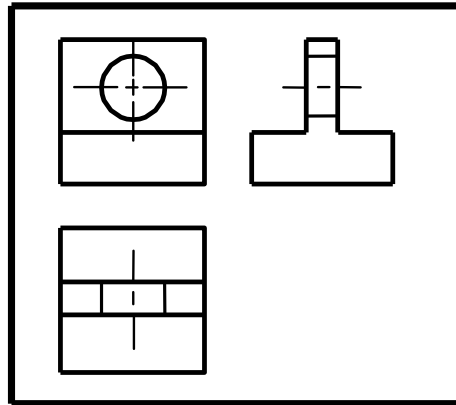
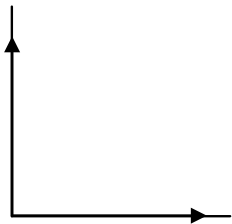

2. Draw line OC as the receding line.

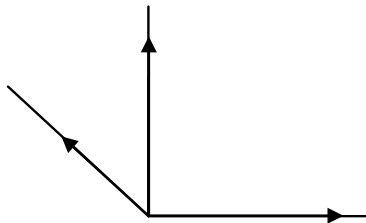

3. Complete the oblique box by sketching parallel lines to the oblique axes.

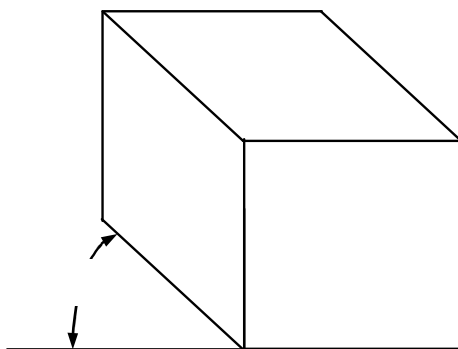

4. Layout the details of the object inside the oblique box.

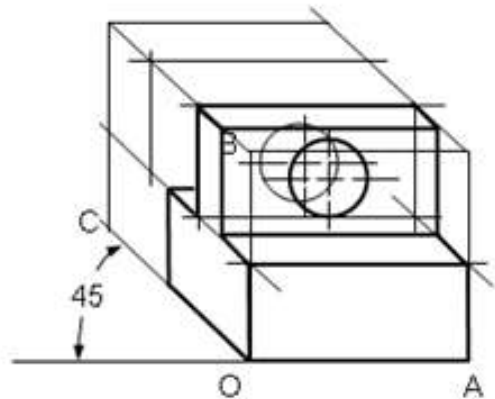
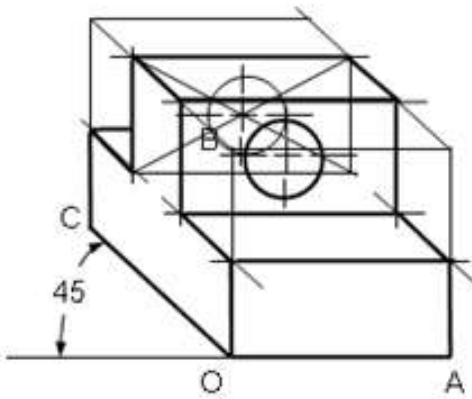
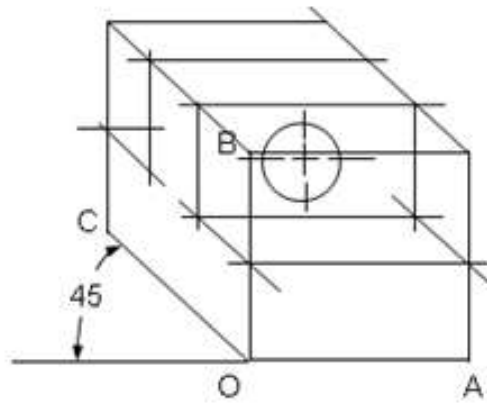

5. Erase the unnecessary lines to complete the drawing.

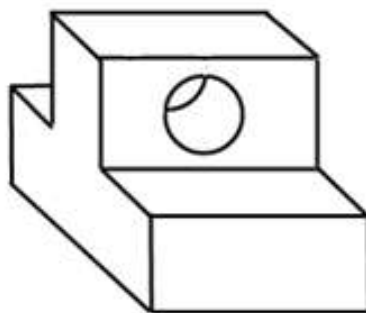

CAVALIER OBLIQUE

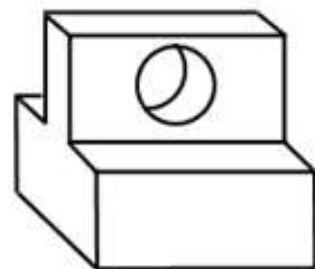

CABINET OBLIQUE



How Much Have You Learned?

Self-Check 1.6

Instructions: You have just finished the study of the basic principles of oblique drawing. To ensure understanding, try your best to supply the needed information to complete the following statements.

_____ 1. A drawing that shows a front view in its true relations and dimensions just as it would be in working drawing.

- a. Isometric drawing
- b. Oblique drawing
- c. Orthographic drawing
- d. Perspective drawing

_____ 2. This type of oblique pictorial view where you can see the exact dimension of the object.

- a. Cabinet projection
- b. Cavalier projection
- c. Isometric projection
- d. Orthographic projection

_____ 3. The receding lines in oblique pictorial drawing regularly used

- a. 30 degrees
- b. 45 degrees
- c. 60 degrees
- d. 75 degrees

_____ 4. This is the type of oblique pictorial view where the dimension of the receding features of the object is drawn half-scale.

- a. Cabinet projection
- b. Cavalier projection
- c. Isometric projection
- d. Orthographic projection

_____ 5. Give at least three rules to be followed in sketching oblique views.

5.1 _____

5.2 _____

5.3 _____

Refer to the Answer Key. What is your score?



How Do You Apply What You Have Learned?

Show that you learned something by doing this activity

Activity Sheet 1.6

Directions: Below is a simple activity for you to work on. Sketch the oblique pictorial of the given orthographic views. Practice the task following the given procedure.

Tools and materials:

- Drawing paper or a long bond paper
- Pencil
- Eraser

Equipment:

- Drawing Table (Drafting Table or Drawing Board)

Procedure

1. Study carefully the given orthographic views. Sketch the vertical line and horizontal line that will serve as your axes.
2. Draw the receding line.
3. Complete the oblique box by sketching parallel lines to the oblique axes.
4. Layout details of the object inside the box then finish the pictorial view by drawing the object lines.
5. Double check your drawing then erase unnecessary lines.

Sample orthographic views

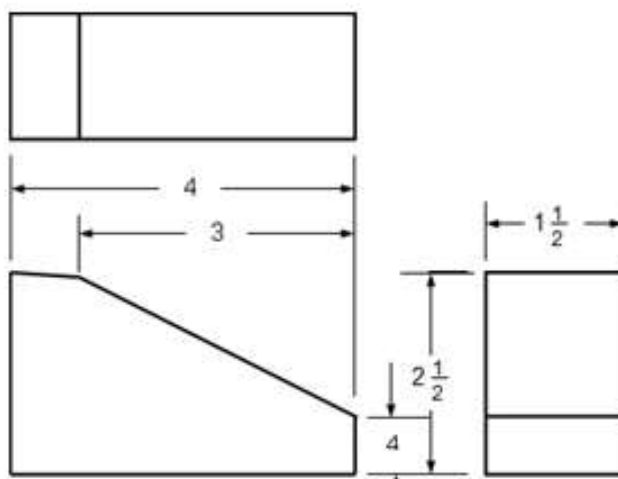



How Well Did You Perform?

Find out **by accomplishing the Scoring Rubric honestly and sincerely.**
Remember it is your learning at stake!

Criteria for Assessment:

Analytic Scoring Rubrics

Criteria	5 points	3 points	1 point
Accuracy	The pictorial view was drawn appropriately in freehand	The pictorial view was somehow drawn inappropriately and/or NOT in freehand	The pictorial view was inappropriately drawn and/or NOT in freehand
Neatness	Finished output was neatly done, pleasing, and no erasures/smudges	Pleasing but erasures and smudges are observable on the finished output	Finished output have so many erasures and smudges and quite unpleasant
Time Management	Finished the task 10 minutes before the given time	Finished the task on time	Unable to finished the given task

Rating Scale:

Points Earned	Numerical	Descriptive
12 - 15	91 - 100	Very Good
8 - 11	86 - 90	Good
4 - 7	81 - 85	Fair
1 - 3	75 - 80	Needs Improvement

Remarks:



What Do You Need To Know?

Read the Information Sheet very well then find out how much you can remember and how much you learned by doing Self-check 1.8.

Information Sheet 1.8

SCALING

Proportion - Size or distance in comparison to another.

Proportion Scale - A scale for measuring distances for drawings. Marks on a proportion scale indicate the reduced size in proportion to the full or actual scale.

Scale - A graduated measurement to allow production of a drawing to any size desired.

The Scale

To draw accurate drawings, you must measure accurately and develop the ability to measure distances. The measuring tool, called the scale (*commonly known as the metric scale*), has several edges. Each edge is called the proportion scale. It helps the drafter to reduce or enlarge the drawing of an object in proportion to its actual size.

Function of a Scale

1. To measure or layout line distances accurately either in full size and larger or smaller than full size.
2. To produce drawing to a certain sizes (making drawing into scale)

The Scale Ratio (Object/Drawing)

Scale ratio 1 : 1 - means that 1 mm. on the drawing represent 1 mm. on the actual product or work piece.

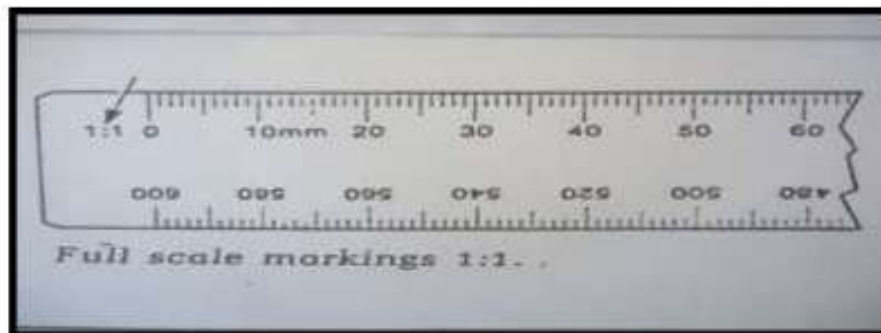

Each mark as you pass represents one millimeter from zero.

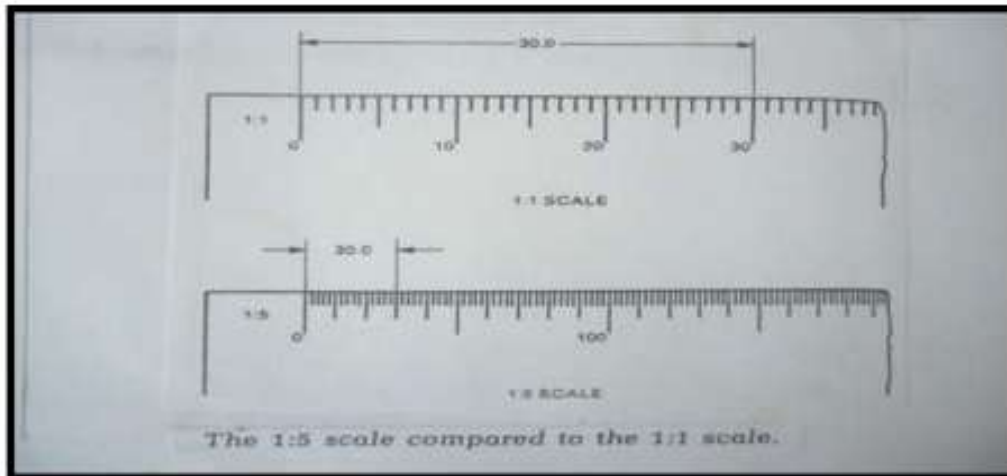

Proportion Scales

Most drafting scales are equipped with proportion scales. Each of these scales aids the drafter in reducing an object on a drawing in a different proportion.

Commonly Used Scale

Full-Size Scale - has a ratio of 1:1. This means that 1 mm on the drawing represents 1 mm of the actual object. The views on the drawing paper are the same size as those of the actual object.



Reduced Scale (Scaled-down) - has a ratio of 1:2. This means that 1 mm on the drawing represents 2 mm on the actual object. The actual object is twice the size of the drawing.

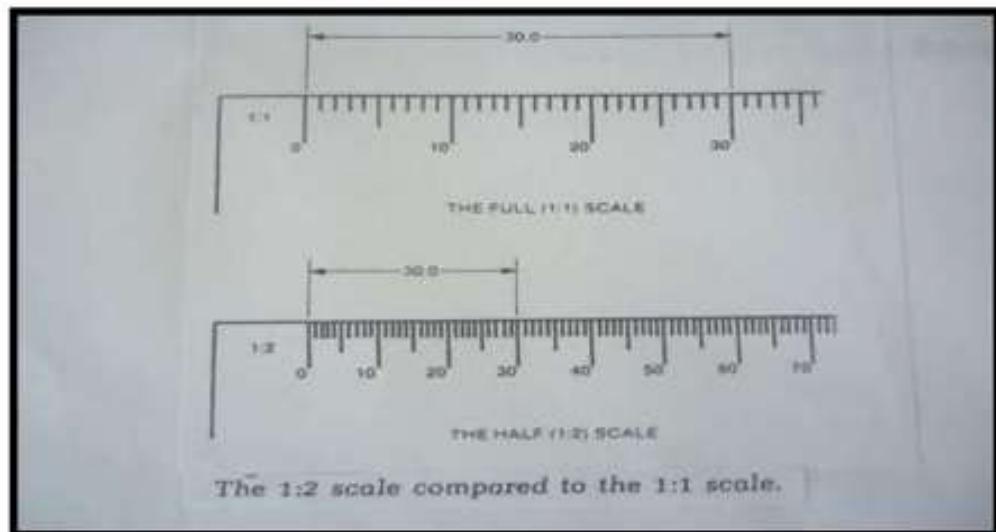

Sometimes, you want to show the shapes of the objects clearly and be able to show the dimensions more conveniently. You have to prepare drawings that are larger than the actual object. Listed below are sample of enlarged scale.

Enlarged Scale (Scaled-up)

Scale 2:1 - This means that every 2 mm on the drawing represents 1 mm on the actual object. The views on the drawing paper are twice the size of those of the actual object.

Scale 5:1 - This means that every 5 mm on the drawing represents 1mm on the actual object. The views on the drawing paper are five times larger than those of the actual object. \

Things to Remember in Scaling a Drawing

1. Whenever possible, the work piece must be drawn in full-size.
2. When dimensioning, always enter the actual dimension of the work piece.
3. Angular dimensions remain the same regardless of the scale to which an object is drawn.
4. The first figure of a scale designation refers to the dimension used to construct the views. The second figure of a scale designation refers to the actual dimensions of the object being drawn.



How Much Have You Learned?

Self-Check 1.8

Directions : You have just finished the study of the basic principles of scaling. To ensure understanding, try your best to interpret the following scale designations.

1. 3:1
2. 10:1
3. 1:15
4. 1:1
5. 1: 20
6. 50:1
7. 1:75
8. 100:1
9. 1:200
10. 500:1

Refer to the Answer Key. What is your score?



What Do You Need To Know?

Read the Information Sheet very well then find out how much you can remember and how much you learned by doing Self-check 1.9.

Information Sheet 1.9

Dimensioning

Dimensioning - placing sizes and related information on a drawing

Size dimension - gives the detail and overall sizes of the object

Location dimension - merely locates part or parts and features of the object

Dimensioning Method

Aligned Method

All dimensions are placed aligned with the dimension line and be read from either the bottom or right side of the paper.

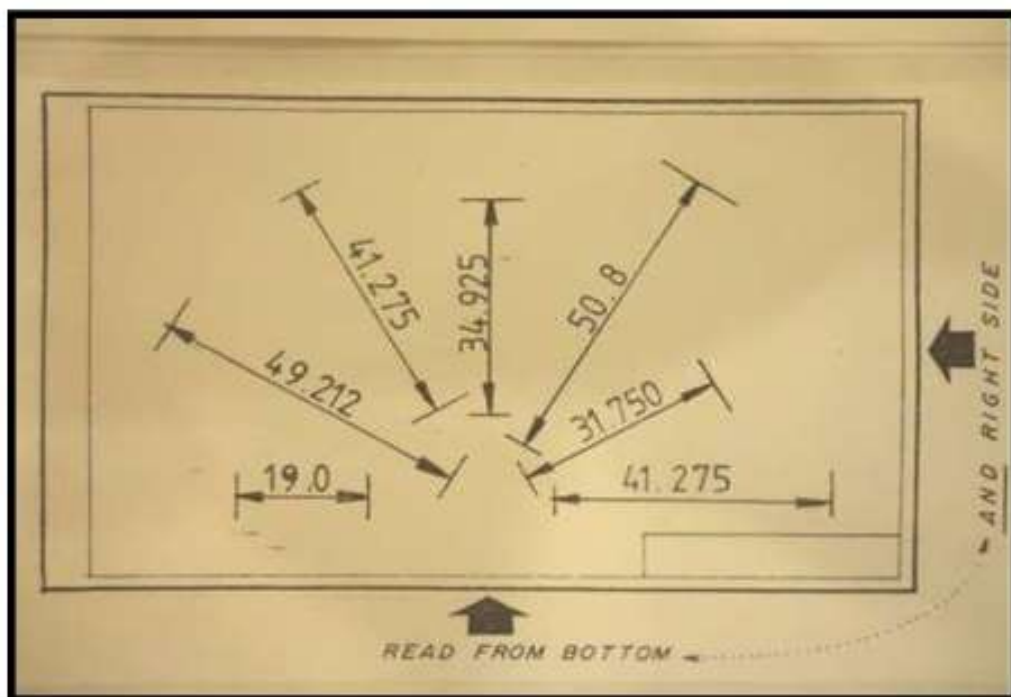

Unidirectional Method

In the unidirectional method, all dimensions are read from the bottom of the page as illustrated. This is a new method.

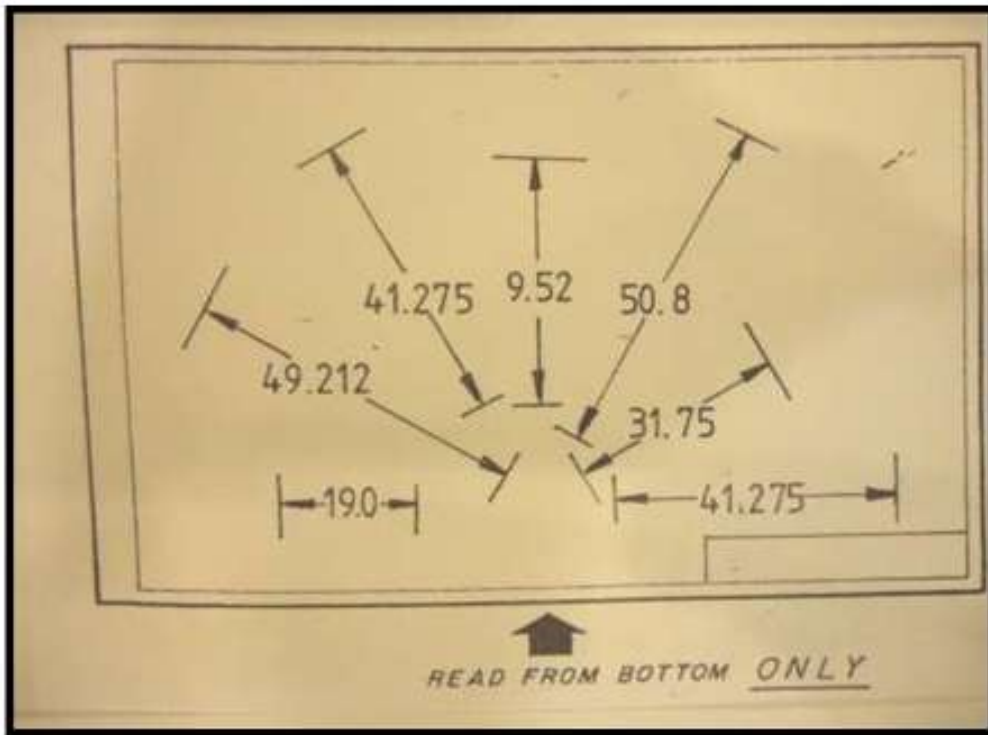

Kinds of Dimensions

Over-all dimension - every object, regardless of its shape, has three over-all dimensions. An over-all dimension indicates the over-all width, height and depth of an object.

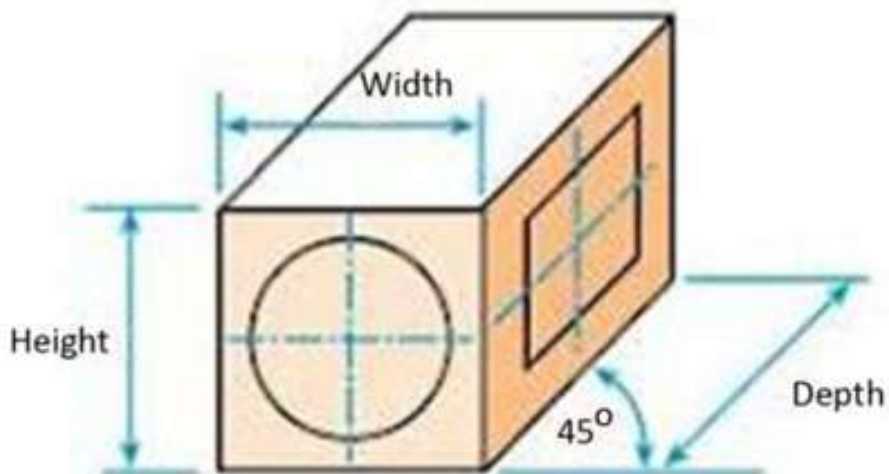

Detail dimensions - provide size or location information concerning any feature or details of an object other than its over-all dimension.

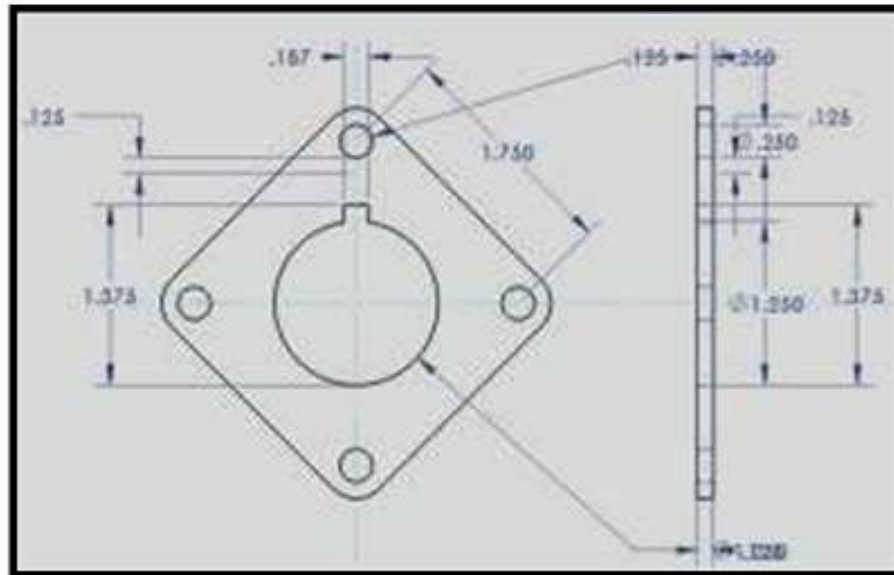

Rules in Dimensioning

For a beginner like you, remember these dimensioning rules when placing measurements in your drawing.

1. Dimensions should be placed between the views.
2. Avoid repetition of dimensions.
3. Use outside dimension if the space is limited, and use an inside dimension if there is enough space.
4. Continuous dimensions should be used whenever possible.
5. Staggered dimensioning should be used when the space for dimensioning is limited.
6. When dimensioning a circle, it should be from center to center.
7. Dimensions without measures are entered in millimeters.
8. Extension lines must have a distance of about 10 mm from the object edge and an approximate 2 millimeters after the dimension lines.



How Much Have You Learned?

Self-Check 1.9

Directions: You have just finished the study of the basic principles in dimensioning. To ensure understanding, try your best to supply the needed information to complete the following statements.

- _____ 1. This is the dimension that gives the detail and overall sizes of the object.
- | | |
|-----------------------|---------------------|
| A. Location Dimension | B. Figure dimension |
| C. Shape Dimension | D. Size dimension |
- _____ 2. This kind of dimension merely locates part or parts of the object.
- | | |
|-----------------------|---------------------|
| A. Location Dimension | B. Figure Dimension |
| C. Shape Dimension | D. Size Dimension |
- _____ 3. This dimension represents the total width, height and depth of an object.
- | | |
|----------------------|-----------------------|
| A Detail Dimension | b. Location Dimension |
| C. Overall dimension | d. Size Dimension |
- _____ 4. The process of describing the object by placing sizes and related information on a drawing.
- | | |
|-----------------|----------------|
| A. Dimensioning | B. Sectioning |
| C. Scaling | D. Tolerancing |
- _____ 5. Type of dimensioning that requires all dimension figures, except to angular contours, be lettered between guide lines that are parallel to the dimension lines.
- | | |
|---------------------|---------------------------|
| A. Aligned Method | B. Location Dimension |
| C Overall Dimension | D. Uni-Directional Method |
- _____ 6. This dimension represents the width, height and the depth of each part of the same object.
- | | |
|----------------------|-----------------------|
| A. Detail Dimension | B. Location Dimension |
| C. Overall Dimension | D. Size Dimension |
- _____ 7. Type of dimensioning that requires all dimension figures be lettered between guide lines that are parallel to the bottom edge of the drawing paper.
- | | |
|----------------------|---------------------------|
| A. Aligned Method | B. Location Dimension |
| C. Overall Dimension | D. Uni-directional Method |

Refer to the Answer Key. What is your score?



Show that you learned something by doing this activity

Operation Sheet 1.9

Directions: Below is a simple activity for you to work on. Sketch the orthographic views of the given object. Practice the task following the given procedure.

Provide the appropriate dimensions in each view

Tools and materials:

- Drawing paper or a long bond paper
- Pencil
- Eraser

Equipment:

- Drawing Table (Drafting Table or Drawing Board)

Procedure:

1. Study the given object carefully.
2. Sketch the regular views of the given object then provide dimensions in each views using the Aligned Method of dimensioning.
3. Strictly observe the following dimensioning rules:
 - a. Dimensions should be placed between the views.
 - b. Avoid repetition of dimensions.
 - c. Use outside dimension if the space is limited, and use an inside dimension if there is enough space.
 - d. Continuous dimensions should be used whenever possible.
 - e. Staggered dimensioning should be used when the space for dimensioning is limited.
 - f. Dimensions are entered in millimeters without measures.
 - g. Extension lines must have a distance of about 10 mm from the object edge and an approximate 2 millimeters after the dimension lines.

(Figure 1)



Note: Do not include the two (2) holes in your orthographic views.

(Figure 2)

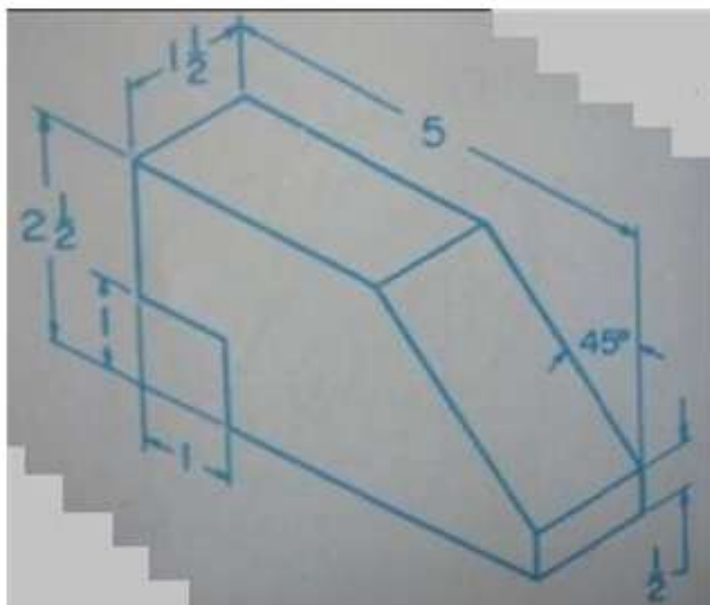



How Well Did You Perform?

Find out by accomplishing the Scoring Rubric honestly and sincerely. Remember it is your learning at stake!

Criteria for Assessment:

Analytic Scoring Rubrics

Criteria	5 points	3 points	1 point
Accuracy	Measurements supplied in each view were based on the given rules	There were some measurements that did not comply with the given rules	Most of the supplied measurements do not comply with the given rules
Neatness	Finished output was neatly done, pleasing, and no erasures/smudges	Pleasing but erasures and smudges are observable on the finished output	Finished output has so many erasures and smudges and is quite unpleasant
Time Management	Finished the task 10 minutes before the given time	Finished the task on time	Unable to finish the given task

Rating Scale:

Points Earned	Numerical	Descriptive
12 - 15	91 - 100	Very Good
8 - 11	86 - 90	Good
4 - 7	81 - 85	Fair
1 - 3	75 - 80	Needs Improvement

Remarks:



What Do You Need To Know?

Read the Information Sheet very well then find out how much you can remember and how much you learned by doing Self-check 1.10.

Information Sheet 1.10

Preparation of Working Plans

Assembly Working Plans

An assembly working plan indicates how the individual parts of a machine or products are assembled to make a complete unit. An assembly working plan serves the following purpose:

1. It describes the shape of the assembled unit or product.
2. It shows how the parts of the assembled unit are positioned in relation to each other.
3. It identifies each component that forms part of the assembled product.
4. It provides parts list that describes and essential data concerning each part of the assembled unit or product.
5. It provides, when necessary, reference information concerning the physical or functional characteristics of the assembled unit.

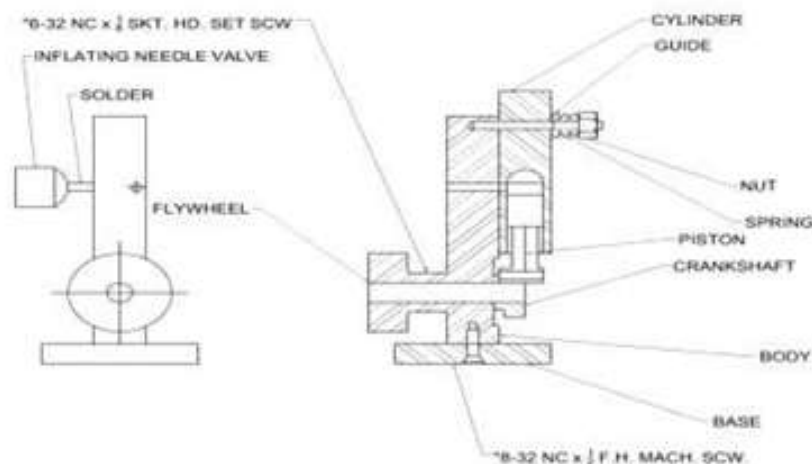

Sample Assembly Working Drawing

Detail Working Plans

A technical working plan of a single part of a machine or mechanism gives enough information to allow the part to be made. It describes the shape and indicates the dimensions of the object.

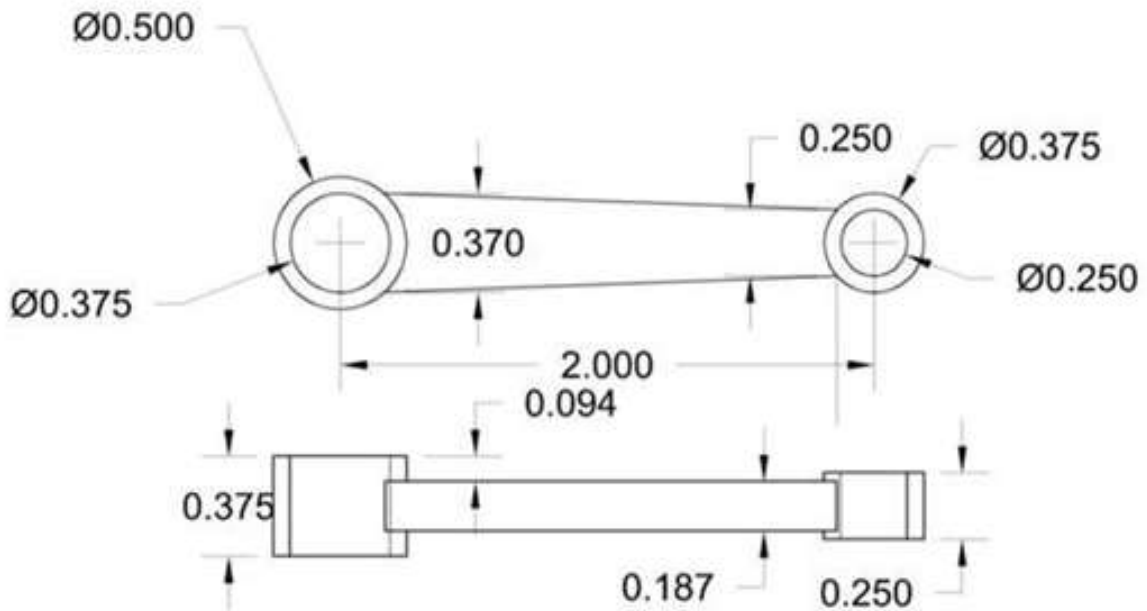

Sample Detail Working Drawing

Parts List

A parts list is a list of all parts required to put an assembly together. This list itemizes important data about each part of an assembled machine or product such as part name, material, quantity required, and size specifications.

Sample figure below shows a simple parts list along with suggested dimensions. In the material column STD abbreviation represents for all standard parts. This means that they must be purchased. Complete specifications for standard parts must always be listed in the name column together with the part name.

Only the names of non-standard parts are listed in the name column. The material from which the standard parts are made is listed by abbreviations in the material column such as C.I., H.R.S., C.R.S., Alum.

The upper or lower right-hand corner of an assembly working plan is usually reserved for the parts list.

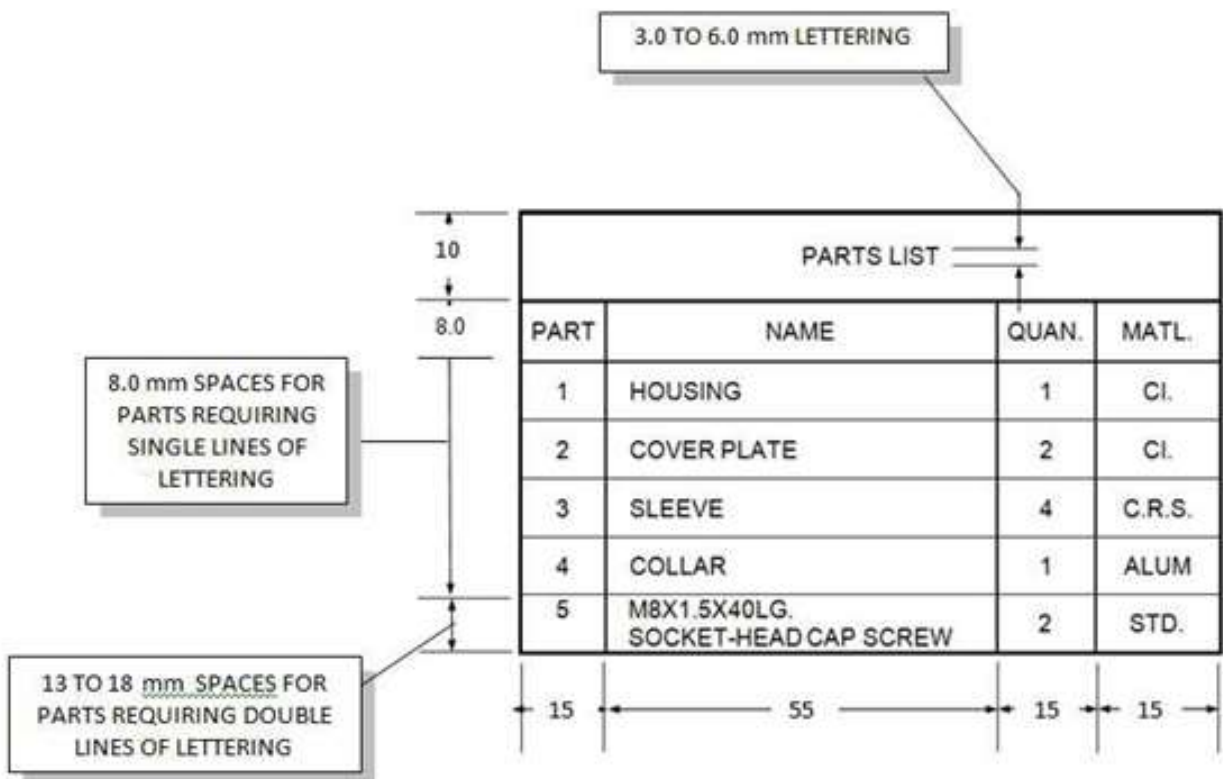

Sample Parts List

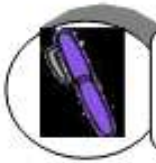

How Much Have You Learned?

Self-Check 1.10

Directions : You have just finished the study of the basic principles in assembly and detail working plans. To ensure understanding, carefully study the given samples below and complete the table for the parts list.

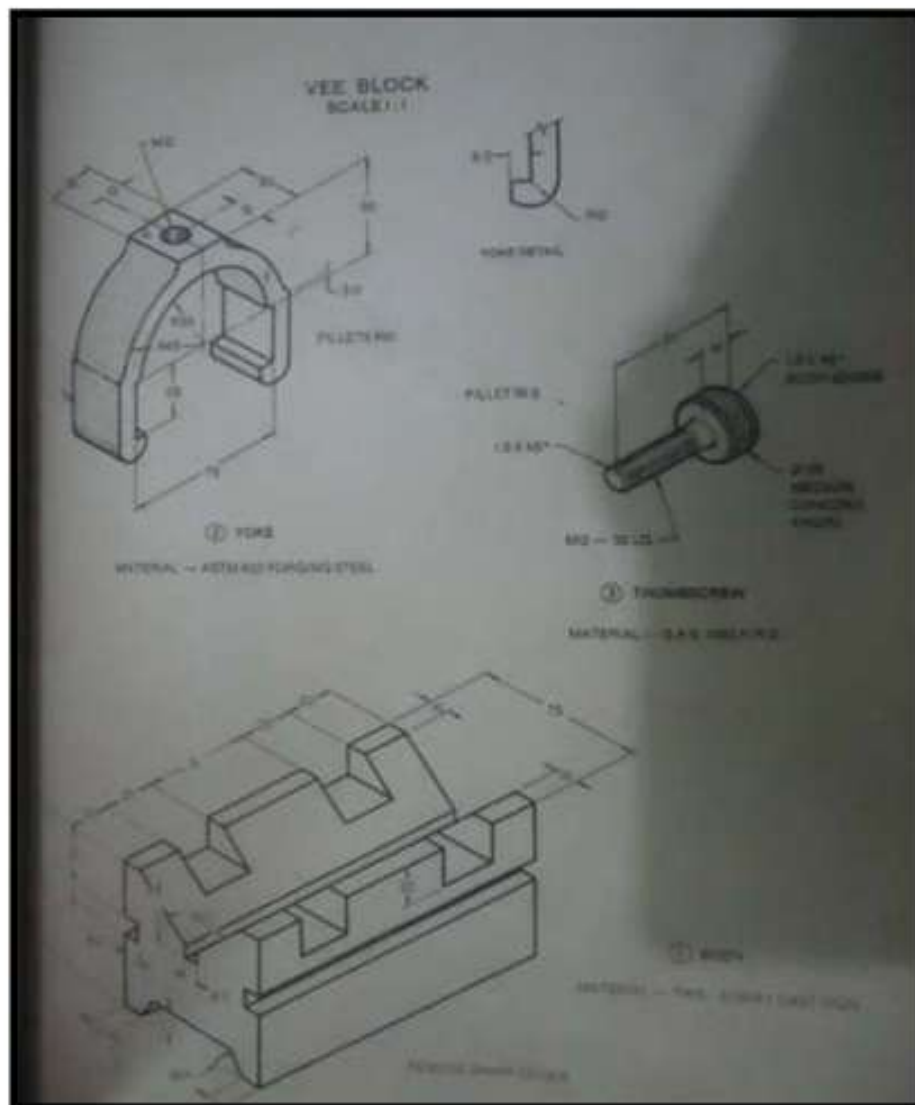

Figure 3) Vee Block

Vee Block			
Part	Name	Quantity	Material

Refer to the Answer Key. What is your score?



How Do You Apply What You Have Learned?

Show that you learned something by doing this activity

Operation Sheet 1.10

Directions: You have just finished the study of the basic principles in assembly and detail working plans. To ensure deeper understanding on reading and interpreting working plans, do the given sample tasks below and complete the table for the parts list. (Figures 4 and 5)

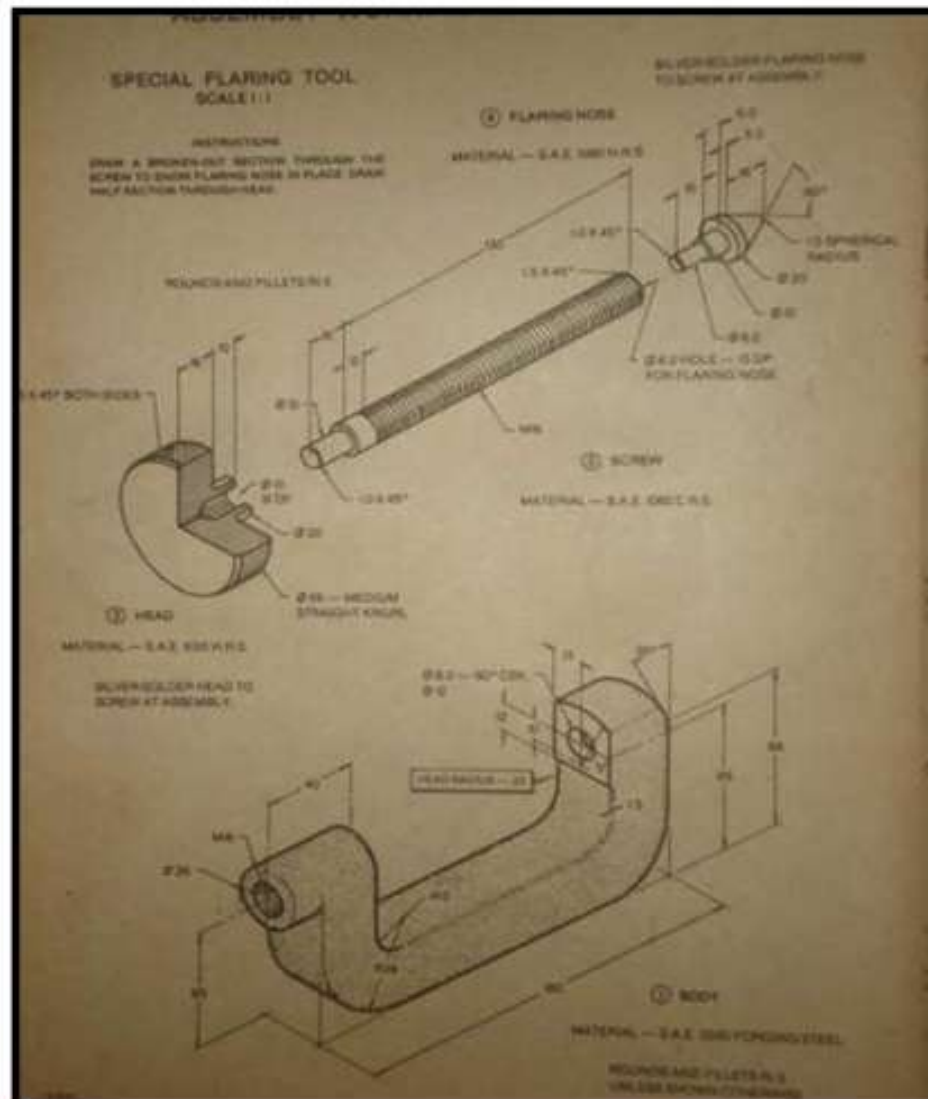

(Figure 4) Special Flaring Tool

Part	Name	Quantity	Material

Directions: Provide the complete parts list of the Toolmaker's Vise on the table below.

(Figure 5) Toolmaker's Vise

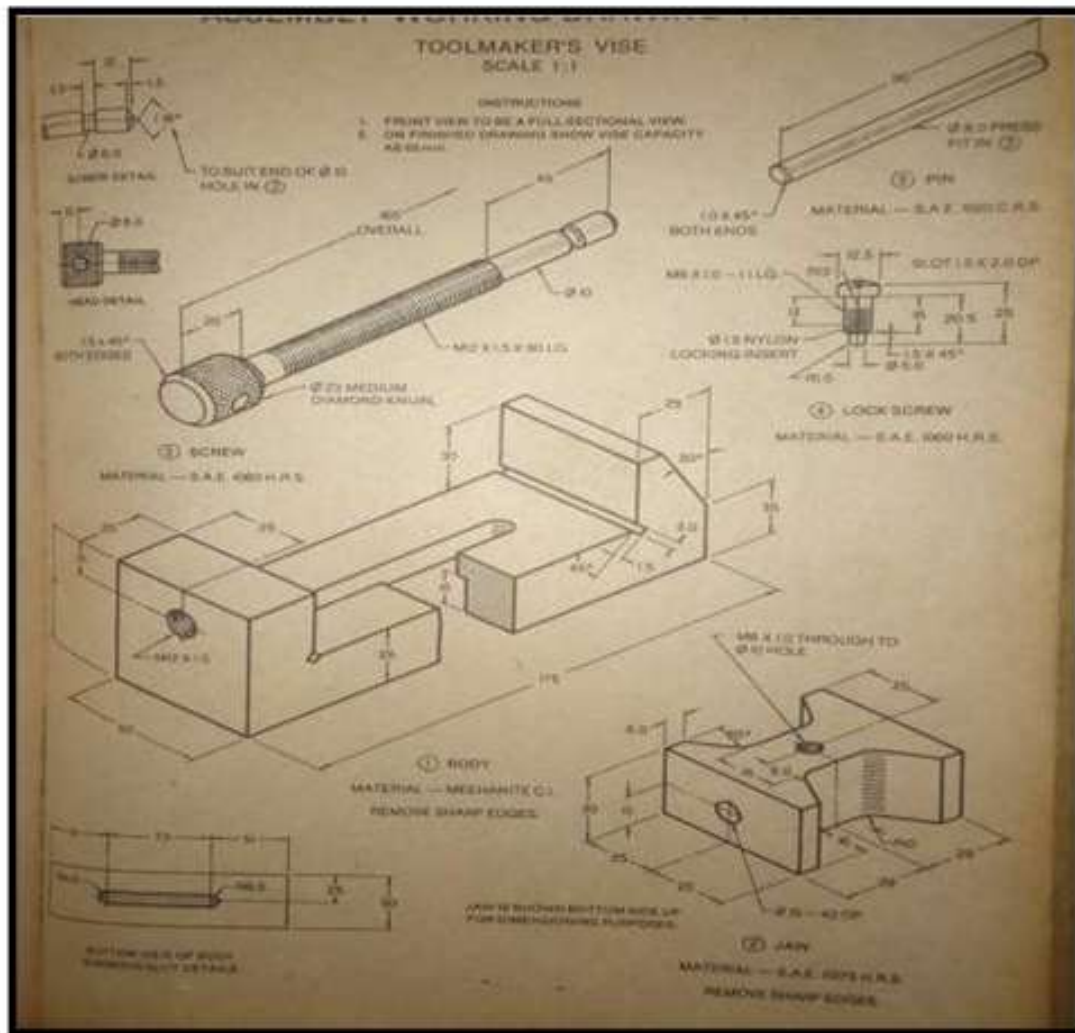

Part	Name	Quantity	Material



Congratulations!
You did a great job! Rest and relax a while then move on to the next lesson. Good luck!

REFERENCES

LO1

Giesecke, Mitchell and Spencer, Technical Drawing; The Macmillan Company: 1999

Nelson, John, How to Read and Understand Blueprints, Van Nostrand Reinhold Company, 1982

Manaois, German, Drafting 1 and 2; Phoenix Publishing: 1983

Esguerra and Molino, Exploratory Drafting; Abiva Publishing: 1980

Walker, John, Exploring Drafting Basic fundamentals, The Goodheart-Willcox Co., Inc, 1975

LESSON 4

Apply Safety Practices



LEARNING OUTCOMES:

At the end of this Lesson, you are expected to do the following:

- LO 1. identify hazardous areas;
- LO 2. use personal protective clothing and devices

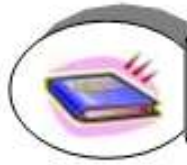

Definition of Terms

Ergonomic principles - a principle of handling a delicate object or task. **First aid** - it implies includes all forms of remedies given immediately to humans in order to minimize or prevent casualties or fatalities caused by accidents or normal course of time.

Hazard - particular place, thing, or situation that is a risk or danger to the person involved.

Health - overall condition of the body

Injury - damage or harm caused to the structure or function of the body caused by an outside agent or force, which may be physical or chemical.

Quality standards - set of exact specifications to become patterns of actions.

Sanitize - maintain high standard of housekeeping.

Self-Discipline - refers to doing things spontaneously without being told or ordered.

Standard - any established measure; an accurate type; an authoritative model as an example or comparison.

Symbols - generally common illustrations printed on the signs which sometimes carry a descriptive word or few words.

Waste disposal - proper discharge of any solid waste into or in any hand

Workplace - office, premises or worksite where a worker is temporary or habitually assigned.

Acronyms

OHSC - Occupational Health and Safety Commission

OHSS - Occupational Health and Safety Standards

PPE - Personal Protective Equipment actions.

LEARNING OUTCOME 1

Identifying Hazardous Area

PERFORMANCE

1. Hazards are identified correctly in accordance with OHS procedures.
2. Safety signs and symbols are identified and adhered to in accordance with workplace safety procedure.



Materials

- a. Drawing paper
- b. Pencil
- c. Any coloring medium



What Do You Already Know?

Let us determine how much you already know about the identifying hazardous area. Take this test.

Pretest LO 1

A. Multiple Choice. Write the letter of the correct answer.

_____ 1. It will be used only to warn or caution against practices.

- A. Caution sign B. Danger sign C. Exit sign D. Safety sign

_____ 2. This preventive sign shall be used only where an immediate hazard exists.

- A. Caution sign B. Danger sign C. Exit sign D. Safety sign

_____ 3. This is a cross-disciplinary area concerned with protecting the safety, health and welfare of people engaged in work or employment.

- A. Occupational Safety and Health C. Occupational Labor Code
B. Department of Labor and Employment D. Department of Trade and Industry

_____ 4. Occupational safety and health requirements may be reinforced in civil law and/or criminal law.

- A. Economic B. Labor C. Legal D. Moral

_____ 5. Take out unnecessary items and dispose.

- A . Seiri B. Seiketsu C. Seiso D. Shitsuke.

_____ 6. Arrange necessary items in good order for use.

- a . Seiri B. Seiketsu C. Seiso D. Seiton

_____ 7. Do things spontaneously without being told or ordered.

- A . Seiri B. Seiketsu C. Seiso D. Shitsuke.

_____ 8. This type of hazards are solid, liquid, vapor or gaseous substances, dust, fume or mist.

- A . Biological B. Chemical C. Ergonomic D. Safety

_____ 9. Refers to inadequate and insufficient machine guards, unsafe workplace conditions, unsafe work practices.

- A . Biological B. Chemical C. Ergonomic D. Safety

_____ 10. This is caused by organisms such as viruses, bacteria, fungi and parasites.

- A . Biological B. Chemical C. Ergonomic D. Safety

Check if your answers are correct by comparing them with those in the Answer Key.

If you got 90-100% of the items correct, that means you already familiar with the lesson covered by Learning Outcome No. 3. However you may still study the lesson to refresh your memory and learn new concepts.

If you missed a lot of items, do all the activities again to gain knowledge and skills required for mastery.



What Do You Need To Know?

Read the Information Sheet 1.1 very well then find out how much you can remember and how much you learned by doing Self-check 1.1.

Information Sheet 1.1

OCCUPATIONAL SAFETY AND HEALTH

Occupational Safety and Health is a cross-disciplinary area concerned with protecting the safety, health and welfare of people engaged in work or employment. As a secondary effect, it may also protect co-workers, family members, employers, customers, suppliers nearby communities, and other members of the public who are affected by the workplace environment.

Occupational Health should aim to:

1. promote and maintain the highest degree of physical, mental and social well being of workers in all occupations;
2. place and maintain the worker in an environment suitable to his physiological and psychological capabilities;
3. protect workers from risk resulting from factors adverse to health; and
4. prevent workers from resignation due to health caused by poor working conditions.

The reasons for establishing good occupational safety and health standards are frequently identified as:

- Moral - an employee should not have to risk injury at work, nor should others associated with the work environment.
- Economic - many governments realize that poor occupation and health per result in cost to the State (e.g. through social security payments to the incapacitated, costs for medical treatment, and the loss of the “employability” of the worker). Economic studies human welfare in terms of the production, distribution, and consumption of goods and services.
- Legal - Occupational safety and health requirements may be reinforced in civil law and/or criminal law.

Safety Standards are standards designed to ensure the safety of products, activities or processes and others.

OSHC Workplace Regulations

1. The place and all equipment and furnishings are maintained in thoroughly safe, clean and hygienic condition and in good repair.
2. Keep the place free from rodents, cockroaches and other vermin.
3. Provide adequate facilities for hand washing, cleaning and disposing of waste.
4. Establish proper procedures for infection control.
5. Keep the floor area and free from waste, water and grease.
6. Keep cabinets dry, clean and close tightly.



How Much Have You Learned?

Self-Check 1.1

Directions: Identify the following terms below. Use a separate sheet of paper for your answers.

- _____ 1. The standards designed to ensure the safety of products, activities or processes and others.
- _____ 2. An employee should not have to risk injury at work, nor should others associated with the work environment.
- _____ 3. Occupational safety and health requirements may be reinforced in civil law and/or criminal law.
- _____ 4. A cross-disciplinary area concerned with protecting the safety, and welfare of people engaged in work or employment.
- _____ 5. It refers to human welfare in terms of the production, distribution, and consumption of goods and services.

Refer to the Answer Key. What is your score?



What Do You Need To Know?

Read the Information Sheet 1.2 very well then find out how much you can remember and how much you learned by doing Self-check 1.2.

Information Sheet 1.2

One of the principal means of promoting efficiency in drafting is orderliness and neatness. Efficiency in turn will produce accuracy in drawing. The drawing area should be kept clear of equipment not in direct use.

Procedure in Setting up Drawing Tools, Materials and Equipment and Standard Procedure

In preparation for a required task in Mechanical Drafting, student should plan, prepare, and select tools and materials for a particular drawing activity. This is to ensure the correct setting of standard procedure and accuracy of drawings.

The drawing tools, materials and equipment are very expensive items; these are also important in all drafting tasks. Considering its cost and value in drafting activity, it is also important to take care and maintain its usability.

With this, the following considerations are strictly emphasized as Standard Operating Procedure during and after the utilization of the drafting tools, materials and equipment:

Before the start of drafting activity:

1. Select the tools, materials and equipment needed in the assigned task.
2. Properly set up the required tools and materials in a place convenient for you to move and execute your work.
3. Clean the table and tools, see to it that these are free from dust and other elements that would cause damage to your work.
4. Wash your hands with clean water.

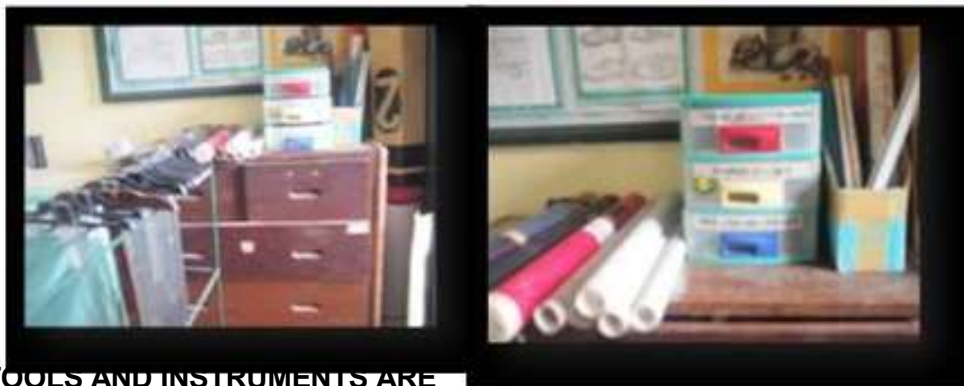

TOOLS AND INSTRUMENTS ARE



Activity proper:

1. Perform the activity by following the standard operating procedure per job requirement.
2. Properly manipulate all the tools and equipment that are used in the activity.
3. In case errors or mistakes along the way (for instance misprinting of lines, letters, and other forms of mistakes) use appropriate eraser.

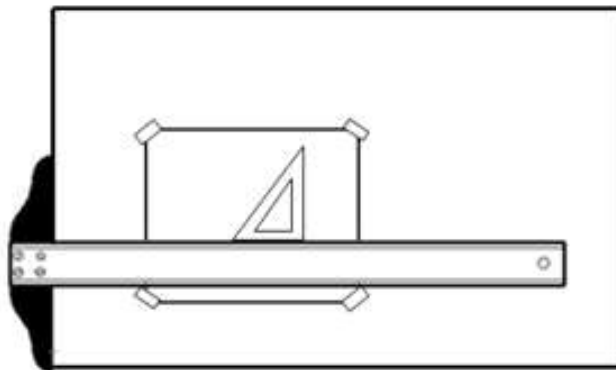

STUDENTS DURING THE ACTUAL DRAFTING
ACTIVITY

After the activity:

1. Submit your output to your teacher for checking
2. Check all the tools and materials to ensure that nothing is lost.
3. Return the tools and materials to the tool keeper.
4. Withdraw your borrower's card from the tool keeper and signed out that you have returned the borrowed tools and materials.
5. Clean your work station before leaving.



INSTRUMENTS FOR PROPER SAFEKEEPING



Other important Practices that must be observed in the work station or work place

There are important practices that must be observed in the work setting. The following are:

1. Observe safety precautions:
 - a. Never smoke inside the work station.
 - b. Never use any tools and equipment without having it clean first.
 - c. Avoid talking with your co-students during working period.
 - d. Always turn off the lights, air condition, ceiling fan, computer units, and other equipment before leaving the work station.
 - e. Maintain cleanliness in the work station.
 - f. Use tools and equipment properly.
2. Observe punctuality of attendance.
3. Avoid quarreling with your co-students.
4. Observe and practice the value of respect.
5. Return the borrowed tools and equipment on time.
6. Observe and practice proper disposal of waste.



How Much Have You Learned?

Self-Check 1.2

Directions: List down some of the pointers and considerations done before, during and after the activity in preparation for a required task in Mechanical Drafting. Use separate sheet of paper.

A. Before the start of drafting activity:

B. During the drafting activity:

C. After the activity proper:

Refer to the Answer Key. What is your score?



What Do You Need To Know?

Read the Information Sheet 1.3 very well then find out how much you can remember and how much you learned by doing Self-check 1.3.

Information Sheet 1.3

Keep Your Workplace Clean and Organized

It is important to consider safety measures whether in the industrial arts laboratory shop, drafting room or in the home workshop. Good housekeeping is one of the sure ways to keep a safe workplace. It is not the result of cleaning up once a week or even once a day. It is the result of keeping the workplace cleaned-up all the time. It is an essential factor in a good safety program, promoting safety, health, production, and morale.

Besides preventing accidents and injuries, good housekeeping saves space, time, and materials. When a workplace is clean, orderly, and free of obstruction, work can get done safely and properly. Workers feel better, think better, do better work, and increase the quantity and quality of their work.

Japanese companies innovated a productivity philosophy called "5S," which stands for five Japanese words that refer to a methodology not only for cleaning, but for business. The 5S methodology is all about eliminating waste, speeding up daily tasks, and improving the quality of the workplace. You can use the 5S methodology to help you organize your tasks at the end of every working day.

Seiri (Sorting)

Take out unnecessary items and dispose. Keep only the items you need at work, and discard or store everything else.



BIODEGRADABLE

DEGRADABLE

Seiton

"Set in order" means that there's a place for everything, and everything should be in its place. Arrange necessary items in good order for use.



Seiso (Sweeping)

At the end of each working day, take time to clean up your office space. Clean up any mess you make.



Seiketsu (Standardizing)

Maintain high standard of housekeeping



Shitsuke (Sustaining)

Do things spontaneously without being told or ordered.

A systematic and productive workplace is not a one-day-affair just because somebody is observing you.



The 5S system may sound simple, but it demands dedication and commitment. With 5S, you can be sure to complete your cleaning tasks in your workshop in no time.



How Much Have You Learned?

Self-Check 1.3

Direction: Match the different 5's in Column A with illustrations or symbols in column B. Write only the letter of the correct answer. Use a separate sheet of paper.

Column A

_____ 1. Shitsuke (Sustaining)

_____ 2. Seiso (Sweeping)

_____ 3. Seiketsu (Standardizing)

_____ 4. Seiton (Set in Order)

_____ 5. Seiri (Sorting)

Column B

A



B



C



D



E



F



Refer to the Answer Key. What is your score?



What Do You Need To Know?

Read the Information Sheet 1.4 very well then find out how much you can remember and how much you learned by doing Self-check 1.4.

Information Sheet 1.4

Since 1980's, there were about 327,000 people employed in some type of drafting job. Nine out of ten drafters work in industry. Many work in industries making machinery, electrical equipment, and metal products. In the manufacturing sector most drafters work for engineering or architectural consulting firms, construction companies, and public utilities. Some work in local governmental agencies. In this case a student or an individual involved in this kind of work should consider the following facts in the prevention of accidents and hazards.

The Department of Labor and Employment (DOLE) and the Occupational Health and Safety Standards (OHSS) issued D.O. 13, ss 1998, known as the *Guidelines Governing Occupational Safety and Health in the Industry*. It requires employers and establishments to use a safety sign where there is a significant risk to health and safety that has not been avoided or controlled by the methods required under other relevant law, provided the use of a sign can help reduce the risk.

ACCIDENT PREVENTION SIGNS AND SYMBOLS

General

Required signs and symbols shall be visible at all times when work is being performed, and shall be removed or covered promptly when the hazard no longer exists.

Danger Signs

Danger signs shall be used only where an immediate hazard exists. It should be read as the predominating color for the upper panel; outline on the borders; and a white lower panel for additional sign wording.



Caution Signs

Caution signs shall be used only to warn against or caution against practices.

Caution sign shall have yellow as the predominating color; black upper panel and borders; yellow lettering of "caution" on the black panel; and the lower yellow panel for the additional sign wording.

Black lettering shall be used for additional wording.

Standard color of the background shall be yellow ; and the panel, black with yellow letters. Any letter used against the yellow background shall be black. The colors shall be those of opaque glossy samples.

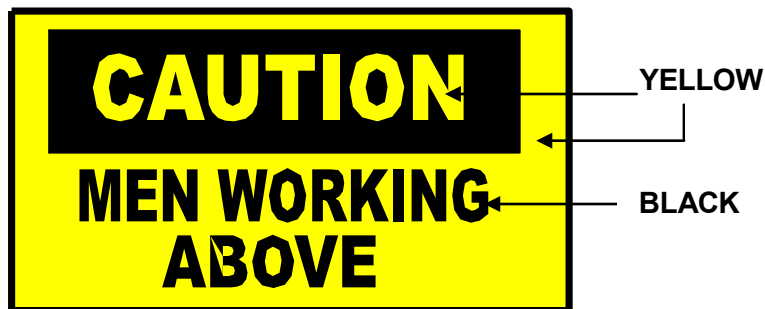

Exit Signs

Exit signs, when required, shall be lettered in legible red letters, not less than 6 inches high, on a white field and the principal stroke of the letters shall be at least threefourths in width.



Safety Instructions Signs

Safety instruction signs, when used, shall have a green upper panel with white letters to convey the principal message. Any additional wording on the sign shall be written in black on the white background.



Directional Signs

Directional signs, other than automotive traffic signs specified shall be white with a black panel and white directional symbol. Any wording on the sign shall be black letters on the white background.









Traffic Signs

Construction areas shall be posted with legible traffic signs at point hazard.

All traffic control signs or devices used for protection of construction workers shall conform to Occupational Safety and Health Administration (OSHA) standards.



Table shows other signs and symbols you have to follow at all times while doing your works inside and outside the shop.

Example	Classification	Meaning/ Usage
 <p>NO ELECTRONIC DEVICES</p>	Prohibition	Do not use in any specified places. It may interfere in the operations of other electronic gadgets in the vicinity
 <p>Danger High voltage</p>	Hazard alerting	BE CAREFUL Warning. It warns everybody of potential dangers around the workplace.
	Prohibition	NOT ALLOWED Danger, alarm. This prohibition reduces risks of fire and prevents personal injury.
	Prohibition	When you see this symbol, picking, smoking, or touching is prohibited
 <p>WARNING Risk of eye injury. Irritation, eye pain, and vision impairment. Eye protection required before opening.</p>	Hazard alerting	Do not perform any activity when your eyes are unprotected.
 <p>DANGER Electrocution hazard. Serious injury can occur if proper precautions are not followed. Do NOT touch or open unless you are fully trained in electrical safety.</p>	Hazard alerting	Danger of electrocution. Do not ignore this sign in the workplace.

	<p>Hazard alerting</p>	<p>Avoid getting into contact to places, equipment or tools with this sign.</p>
	<p>Hazard alerting</p>	<p>High voltage is dangerous and fatal. Keep out of areas where you see signs like this.</p>
	<p>Safety</p>	<p>In all offices, workplaces, and establishments, it is mandatory to have this sign for first aid displayed on conspicuous places. This is where you should run to if accidents happen.</p>
	<p>Hazard avoidance/safety</p>	<p>For good housekeeping, these symbols indicate “recycling” materials. This means that the material is recyclable or where you should place recyclable objects/wastes in the work area.</p>
	<p>Hazard Avoidance</p>	<p>Be careful with falling objects and from being pressed from lathe and other moving machines</p>







How Much Have You Learned?

Self-Check 1.4

Directions: Match Column A with Column B. Write only the letter of the correct answer on a separate sheet of paper.

Column A

Column B

1. DIRECTIONAL SIGN	<input type="checkbox"/> A 
2. CAUTION SIGN	<input type="checkbox"/> B 
3. EXIT SIGN	<input type="checkbox"/> C 
4. SAFETY SIGN	<input type="checkbox"/> D 
5. DANGER SIGN	<input type="checkbox"/> E 

Refer to the Answer Key. What is your score?



What Do You Need To Know?

Read the Information Sheet 1.5 very well then find out how much you can remember and how much you learned by doing Self-check 1.5.

Information Sheet 1.5

Hazards in the Workplace

There are many things that affect the health of a person, such as his environment, his lifestyle, etc. Work is an important determinant of health. It can influence health in a positive or in a negative way.

A place that is safe, healthy and work-conducive entails more productivity. In fact, with a healthy workplace you will be doing more work with less effort.

Hazard is a term used to describe something that has the potential to cause harm.

Risk on the other hand, is a measure of the possibility of a specific harmful effect in given circumstances. It is very important to know the difference between a hazard and a risk.

Types of workplace hazards include:

- Safety hazards** - Inadequate and insufficient machine guards, unsafe workplace conditions, unsafe work practices.
- Biological hazards** - Caused by organisms such as viruses, bacteria, fungi and parasites.
- Chemical hazards** - Solid, liquid, vapor or gaseous chemicals, dust, fume or mist.
- Ergonomic hazards** - Anatomical, physiological, and psychological demands on the worker, such as repetitive and forceful movements, vibration, extreme temperatures, and awkward postures arising from improper work methods and improperly designed workstations, tools, and equipment.
- Physical hazards** - Noise, vibration, energy, weather, electricity, radiation and pressure.
- Psychological hazards** - Those that are basically causing stress to a worker. This kind of hazard troubles an individual very much to an extent that his general well-being is affected.

What are examples of a hazard?

Workplace hazards can come from a wide range of sources. General examples include any substance, material, process, practice, etc that has the ability to cause harm or adverse health effect to a person under certain conditions. See Table 1.

Table 1 Examples of Hazards and Their Effects		
Workplace Hazard	Example of Hazard	Example of Harm Caused
Thing	Knife	Cut
Substance	Benzene	Leukemia
Material	Asbestos	Mesothelioma
Source of Energy	Electricity	Shock, electrocution
Condition	Wet floor	Slips, falls
Process	Welding	Metal fume fever
Practice	Hard rock mining	Silicosis

As shown in Table 1, workplace hazards also include practices or conditions that release uncontrolled energy like:

- an object that could fall from a height (potential or gravitational energy),
- a run-away chemical reaction (chemical energy),
- the release of compressed gas or steam (pressure; high temperature),
- entanglement of hair or clothing in rotating equipment (kinetic energy), or
- contact with electrodes of a battery or capacitor (electrical energy).



SAFETY HAZARDS



BIOLOGICAL HAZARDS



CHEMICAL HAZARDS

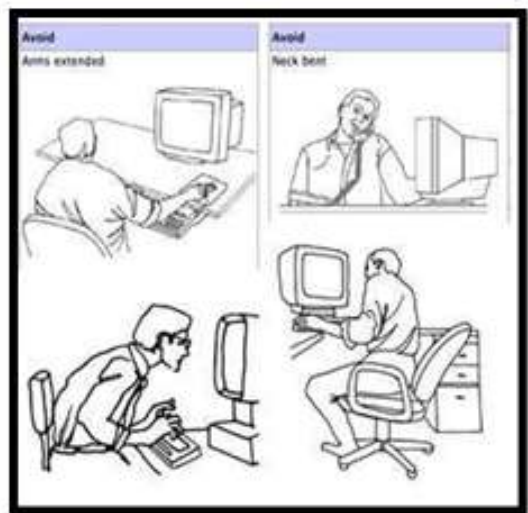

ERGONOMIC HAZARDS



PHYSICAL HAZARDS



PSYCHOLOGICAL HAZARDS



How Much Have You Learned?

Self-Check 1.5

Direction. Select from the list below the type of workplace hazard that matches the given definition or description. Use separate sheet of paper.

BIOLOGICAL	CHEMICAL	ERGONOMIC
PHYSICAL	PSYCHOLOGICAL	SAFETY

- _____ 1. Refers to Inadequate and insufficient machine guards, unsafe workplace conditions, unsafe work practices.
- _____ 2. This is caused by organisms such as viruses, bacteria, fungi and parasites.
- _____ 3. Some examples of this type of hazard are solid, liquid, vapor or gaseous substances, dust, fume or mist.
- _____ 4. Anatomical, physiological, and psychological demands on the worker, such as repetitive and forceful movements, vibration, extreme temperatures, and awkward postures arising from improper work methods and improperly designed workstations, tools, and equipment.
- _____ 5. Noise, vibration, energy, weather, electricity, radiation and pressure.

Refer to the Answer Key. What is your score?

LEARNING OUTCOME 2

Select and Use personal protective clothing and devices

PERFORMANCE

1. Personal protective clothing/equipment (PPE) identified as per job requirements
2. Proper wearing of PPE are properly observed in accordance with workplace safety policies.



Materials

- a. Drawing paper
- b. Pencil
- c. Any coloring medium
- d. PPE's



What Do You Already Know?

Let us determine how much you already know about personal protective clothing and devices. Take this test.

Pretest LO 2

A. Multiple Choice. Write the letter of the best answer.

- _____ 1. The main purpose of wearing this kind of PPE is to protect our limbs and body from metal dusts, flaming combustion, flying chips, minute particles and stray metallic objects from abrasive wheels, drills and cutting tools
A. Cover all B. Protective Headgear C. Safety goggles D. Safety shoes
- _____ 2. A safety helmet or wide-brimmed hat for head protection..
A. Cover all B. Protective Headgear C. Safety goggles D. Safety shoes
- _____ 3. A pair of protective coverings for the hands, usually with separate divisions for the fingers and for the thumb.
A. Apron B. Gloves C. Goggles D. Pot holder
- _____ 4. Safety shoes in the shop designed specifically with hard or metallic materials in the toe areas.
A. Cover all B. Protective Headgear C. Safety goggles D. Safety shoes
- _____ 5. This is a protective instrument for the eyes with transparent eye-pieces.
A. Cover all B. Protective Headgear C. Safety goggles D. Safety shoes

B. Directions: Write T if the statement is *True* and F if the statement is *False*. Use separate sheet of paper.

- _____ 1. Protective helmets must be worn only where there is a risk of falling debris.
_____ 2. The equipment should be well maintained and stored correctly.
_____ 3. A respirator may be required in all workplaces.
_____ 4. Aprons, gloves and shields are necessary where there is possible spillage or splashes of chemical, blood or other hazardous material.
_____ 5. Mechanical Drafting requires headwork and must be done in quiet surroundings.

Check if your answers are correct by comparing them with those in the Answer Key.

If you got 90-100% of the items correct, that means you are already familiar with the lesson covered by Learning Outcome No.2. However you may still study the lesson to refresh your memory and learn new concepts.

If you missed a lot of items, do all the activities to gain knowledge and skills required for mastery.



What Do You Need To Know?

Read the Information Sheet 2.1 very well then find out how much you can remember and how much you learned by doing Self-check 2.1.

Information Sheet 2.1



Mechanical Drafting requires headwork and must be done in quiet surroundings. But sometimes they are also going outside to see the actual project site they are developing and planning for. They have to think and explore other design that will fit the needs of present technology. In this case they must be aware of using the PPE.

Personal Protective Equipment (PPE)

Using personal protective equipment (PPE) helps to prevent the transmission of communicable diseases between patients and health care providers. It can also help to prevent the contamination of exposed wounds or sores from germs or bacteria that can travel from a health care provider to the patient. Knowing how to properly use PPE can help to insure the safety and well-being of health care providers and emergency responders.

Engineering and administrative controls are not exempted in the different hazardous things normally happened in the workplace, the use of Personal Protective Equipment (PPE) protects workers from injury. Personal Protective Equipment must be used and worn in many work situations in order to protect employees from harm.

Types and Uses

Symbol	Name of Personal Protective Equipment	Uses and Functions
	Protective Headgear	A safety helmet or wide-brimmed hat for head protection. This can be used by a draftsman during the actual visitation of the project site.
	Over-all or Cover-all	The main purpose of wearing this kind of clothing is to protect our limbs and body from metal dusts, flaming combustion, flying chips, minute particles and stray metallic objects from abrasive wheels, drills and cutting tools.

	<p>Safety Boots or Shoes</p>	<p>In most cases, safety shoes in the shop are designed specifically with hard or metallic materials in the toe areas.</p>
	<p>Gloves</p>	<p>A pair of protective coverings for the hands, usually with separate divisions for the fingers and for the thumb.</p>
	<p>Safety Glasses or Goggles</p>	<p>This is a protective instrument for the eyes with transparent eye-pieces. It also protect the eyes from absorbing so much light</p>
	<p>Fire extinguisher</p>	<p>A portable device containing chemicals that can be sprayed on a fire to put it out.</p>

Personal Protective Equipment Inspection Checklist

Here are some requirements with which workplaces must abide

Assessments

- A hazard assessment will identify when PPE needs to be used, in what circumstances, and who must wear it.

Maintenance

- The equipment should be well maintained and stored correctly. It must be repaired or replaced when necessary.
- Protective helmets must be worn where there is a risk of falling debris.
- Aprons, gloves and shields are necessary where there is possible spillage or splashes of chemical, blood or other hazardous material.

- Protective, steel-toe boots should be worn where there is a risk of damage to a worker's feet.
- Goggles or other eye-protection devices should be worn whenever there is a danger of the eyes being splashed or damaged in the course of work.

Compliance

- When safety boots or head-protection equipment is worn, it must comply with the Standards Safety Requirements.
- A respirator may be required in some workplaces.
- Eye wash material will need to be kept on the site where there is a danger of splashes in the eyes. Where PPE such as goggles or safety helmets are required, a notice to this effect should be posted at the entrance to the workplace.

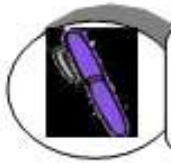

How Much Have You Learned?

Self-Check 2.1

Direction: Identify the following Personal Protective Equipment PPE as show below:

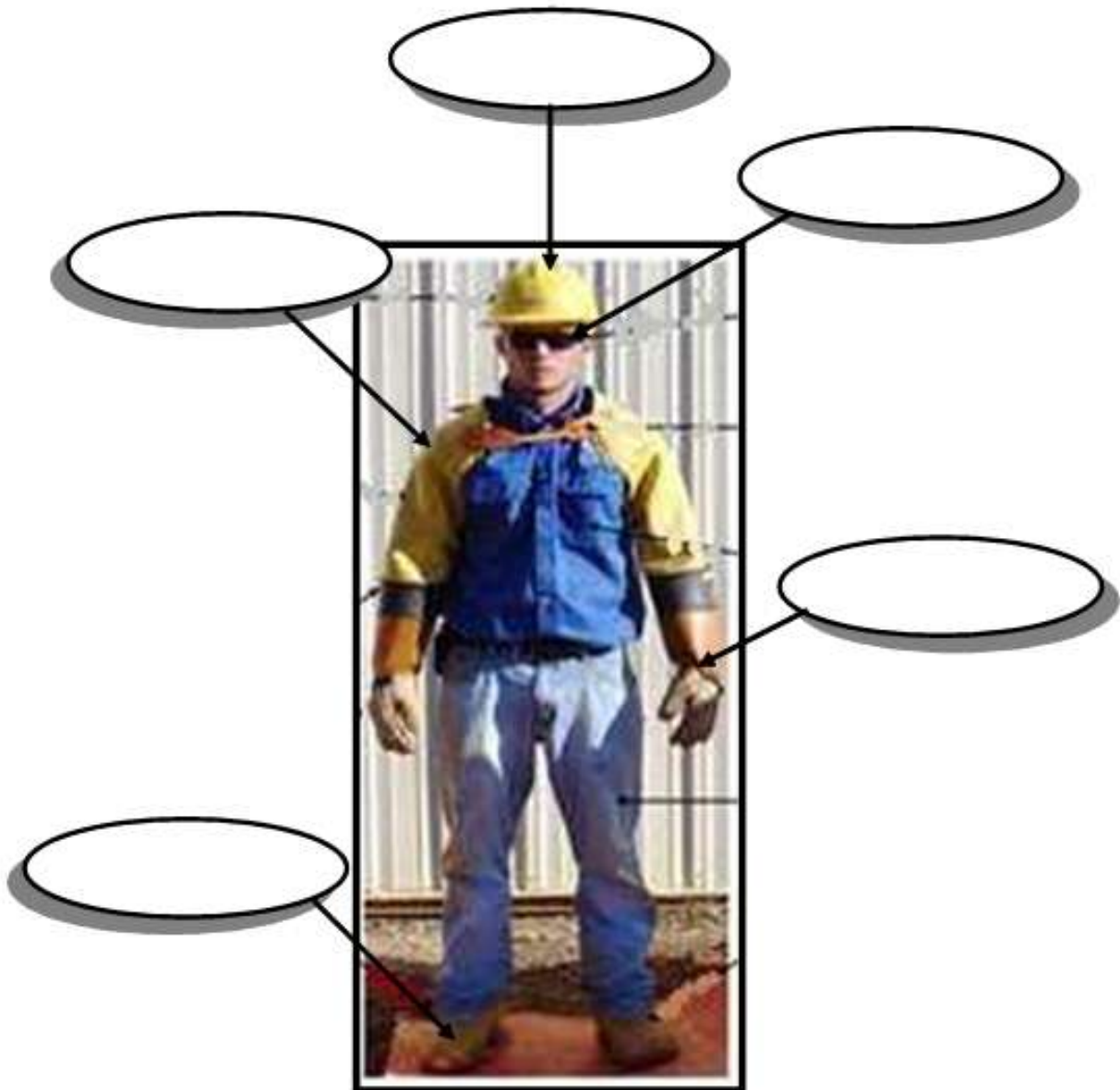

Refer to the Answer Key. What is your score?



How Do You Apply What You Have Learned?

Show that you learned something by doing this activity

Operation Sheet 1.1

Tools and Materials

- Drawing paper
- Pencil
- Any coloring medium

Direction:

1. Design a poster showing the proper use of PPE including the drawing tools and instruments used in the shop. You are free to choose any available colouring medium. The poster should be informative and should clearly show the main message. You will need to undertake some research to complete this activity.
Your poster/ could focus on:
 - Hazard identification and risk assessment in general;
 - The responsibility of your teacher and you as a student.
2. Your work will be graded based on the Evaluation Sheet given.



How Well Did You Perform?

Find out by accomplishing the Scoring Rubric honestly and sincerely. Remember it is your learning at stake!

HOW WELL DID YOU PERFORM?

Criteria for Assessment: Analytic Rubrics Scoring

CRITERIA	5 points	3 points	1 point
Theme	The output is very relevant to the theme	The output is moderately relevant to the theme	The output is somewhat or not relevant to the theme
Originality	The idea or concept is very original	The idea or concept is moderately original	The idea or concept is somewhat or not original
Visual Impact	The output is very attractive	The output is moderately attractive	The output is somewhat or not attractive
Neatness	The output is free from any erasures	The output has one to three erasures	The output has four or more erasures

Rating Scales

POINTS EARNED	NUMERICAL	DESCRIPTIVE
15 - 20	90 - 100	Very Good
10 - 14	86 - 90	Good
5 - 9	81 - 85	Fair
1 - 4	75 - 80	Needs Improvement



Congratulations! You did a great job!

REFERENCES

LO1

- Giesecke, Mitchell, Spencer. Hill and Dygdon, Technical Drawing Eight Edition; The Macmillan Company: 1999
- Competency Based Learning Material, Civil Technology
- Competency Based Learning Material, Drafting Technology
- Competency Based Learning Material, Machine Shop
- Industry, Department of Labor and Employment - Bureau of Working Conditions, D.O. 13, s. 1998.
- Procedural Guidelines Governing Occupational Safety and Health in the Construction
- http://en.wikipedia.org/wiki/Occupational_safety_and_health
- <http://images.search.yahoo.com/search/image>
- http://www.aabr.org.au/vcn/12_2risks.htm
- <http://www.cchs.oshanswers/hsprograms/hazardrisk.html>
- http://www.ehow.com/list_6926722_personal-protective-equipment-checklist.html
- <http://www.sofweb.vic.edu.au/safe@work>
- www.workcover.nsw.gov.au.

Lo 2

Giesecke, Mitchell, Spencer. Hill and Dygdon, Technical Drawing Eight Edition; The Macmillan Company: 1999

Competency Based Learning Material, Civil Technology

Competency Based Learning Material, Drafting Technology

Competency Based Learning Material, Machine Shop

Industry, Department of Labor and Employment - Bureau of Working Conditions, D.O. 13, s. 1998.

Procedural Guidelines Governing Occupational Safety and Health in the Construction

http://en.wikipedia.org/wiki/Occupational_safety_and_health

<http://images.search.yahoo.com/search/image>

http://www.ehow.com/list_6926722_personal-protective-equipment-checklist.html

<http://www.sofweb.vic.edu.au/safe@work>

www.workcover.nsw.gov.au.

ANSWER KEY LESSON 1

LO1. Identify drafting materials and tools/drawing instruments applicable to a specific job.

PRE-TEST

A.

1. C
2. C
3. D
4. A
5. B

B.

1. E
2. A
3. D
4. B
5. C

SELF CHECK 1.1

								R	E	N	E	P	R	A	H	S	L	I	C	N	E	P		
M				D																C				
	A			R															O					
		S		A															M					
			K	W			E									P								
				I	A			R						A										
					N					A		S												
					G	G	S	E	L	A	C	S	S	C	I	R	T	E	M					
R					P		T							E										
O					A			A							R									
T			S		P			P															D	
C			L		E				E													L		
A			I		R																	E		
R			C																					
T			N																					
O			E														H							
R			P													S								
P			G						T	R	I	A	N	G	L	E	S	R						
			N										N										E	
			I						T	I													D	
			W							S													I	
			A						A	Q													V	
			R						R						U								I	
			D						E						A								D	
																	R							
																	E							

ANSWERS:

1. COMPASS
2. DIVIDER
3. DRAWING PAPER
4. DRAWING PENCILS
5. ERASER
6. ERASING SHIELD
7. MASKING TAPE
8. METRIC SCALES
9. PENCIL SHARPENER
10. PROTRACTOR
11. TRIANGLES
12. T SQUARE

LO2. Request, receive and inspect drafting materials and tools/drawing instruments.

PRE-TEST

1. A
2. C
3. D
4. B
5. C

SELF CHECK 2.1

A.

Column A

Column B

1. ROIFYVT MNOENF
2. RLVCDPYT EEEEEIR
3. PRESO ROBRWIL
4. SODEAR CUPREAH
5. FITIMEON SIRUROQ

1. **INVENTORY FORM**
2. **DELIVERY RECEIPT**
3. **BORROWER SLIP**
4. **PURCHASE ORDER**
5. **REQUISITION FORM**

B. Teachers Check

ANSWER KEY Lesson 2

LO1. Select and use measuring instruments

PRE-TEST

1. C
2. C
3. D
4. C
5. D
6. B
7. D
8. A
9. B
10. B

SELF CHECK # 1.1

A.

1. C
2. E
3. D
4. A
5. B

B.

1. Triangle
2. Tape ruler
3. Protractor
4. T-Square
5. Divider

LO2. Clean and store measuring instruments

PRE-TEST

A. Multiple Choice

1. F
2. E
3. D
4. A
5. B

B. Uses and Care of Drafting measuring tools

- Be sure to inspect tools before using them. This is to check if they are in working condition. This can be detected when there is ease and speed when in use.
- After using a tool, clean it thoroughly with a damp cloth. Wipe it dry with another piece of cloth before keeping it.
- When not in use, the T-square is preferably hung by inserting the hole to a nail (attached to a wall) at the end of its blade.
- Do not abuse or misuse any piece of drawing instruments.
- Avoid throwing a tool to anybody; instead, hand it over to him carefully.
- Avoid setting off the distances individually by moving the scale to a new position from time to time, because slight errors in the measurements may accumulate and give rise to a large error.
- Avoid unnecessary sliding of T-square or triangles protect the drawing. Pick up the triangle by its tip and tilt the T-square blade upward slightly before moving.
- Do not pull too much the steel tape of pull-push rule to the coil spring from damage.
- Oil the movable parts of the measuring tools such as zigzag rules, calipers, dividers, and compasses to avoid stock-up.
- Report defective measuring tools and any hazard to instructor immediately.

SELF -CHECK # 2.1

A.

1. T
2. T
3. T
4. T
5. T

B. Uses and Care of Drafting or measuring tools

- Be sure to inspect tools before using them. This is to check if they are in working condition. This can be detected when there is ease and speed when in use.
- After using a tool, clean it thoroughly with a damp cloth. Wipe it dry with another piece of cloth before keeping it.
- When not in use, the T-square is preferably hung by inserting the hole to a nail (attached to a wall) at the end of its blade.
- Do not abuse or misuse any piece of drawing instruments.
- Avoid throwing a tool to anybody; instead, hand it over to him carefully.
- Avoid setting off the distances individually by moving the scale to a new position from time to time, because slight errors in the measurements may accumulate and give rise to a large error.
- Avoid unnecessary sliding of T-square or triangles protect the drawing. Pick up the triangle by its tip and tilt the T-square blade upward slightly before moving.
- Do not pull too much the steel tape of pull-push rule to the coil spring from damage.
- Oil the movable parts of the measuring tools such as zigzag rules, calipers, dividers, and compasses to avoid stock-up.
- Report defective measuring tools and any hazard to instructor immediately.

LO3. Convert fraction to decimal and vice versa

PRE-TEST

TEST I. A. Convert fractions into decimals

1. .25
2. .75
3. .04375
4. .375
5. .125

B. Convert decimals into fractions .

6. $\frac{7}{50}$
7. $\frac{6}{25}$
8. $\frac{3}{4}$
9. $\frac{1}{8}$
10. $\frac{3}{20}$

C. Round off the following numbers to their nearest hundredths.

11. 76.35
12. 93.67
13. 27.01
14. 4.62
15. 5.25

SELF -CHECK # 3.1

A.

1. .25
2. .75
3. .04375
4. .375
5. .125

B.

1. 13.76
2. 38.61
3. 41.01
4. 8.62
5. 7.25

C.

1. $\frac{1}{5}$
2. $\frac{4}{5}$
3. $\frac{21}{25}$
4. $\frac{7}{50}$
5. $\frac{6}{25}$
6. $\frac{3}{4}$
7. $\frac{1}{8}$
8. $\frac{3}{20}$
9. $\frac{13}{20}$
10. $\frac{3}{8}$

LO4. Convert English to Metric measurement and vice versa

PRE-TEST

A.

1. 9.84 inches
2. 206.69 or 206.70 feet
3. 15.24 meters
4. 4. 0.33 meters
5. 5. 0.39 inch

B.

6. 1" 1/16
7. 3/8
8. 13/16"
9. 2.1 cm
10. .75 cm

SELF -CHECK # 4.1

A.

1. 13/16
2. 5/8
3. 5/16
4. $\frac{3}{4}$
5. 1-7/8
6. 2-1/2

B.

7. 13 mm or 1.3 cm
8. 37 mm or 3.7 cm
9. 4 mm or .4 cm
10. 75 mm or .75 cm

II.

1. 23.52 or 24 inches
2. 8.89 cm
3. .75 cm.
4. 25.4 cm.
5. 0.98 or 1 ft

ANSWER KEY - LESSON 3

LO1. Identify Detailed and Assembly Drawing.

PRE-TEST

- A. 1. A
- 2. B
- 3. D
- 4. A
- 5. D
- 6. B
- 7. D
- 8. A
- 9. B
- 10. C
- 11. A
- 12. B
- 13. A
- 14. A
- 15. D

SELF-CHECK 1.1

- | | |
|-------------------|-----------------------|
| A. Leader line | H. Hidden line |
| B. Dimension line | I. Object line |
| C. Extension line | J. Leader line |
| D. Hidden line | K. Cutting-plane line |
| E. Dimension line | L. Object line |
| F. Hidden line | M. Extension line |
| G. Object line | N. Object line |

SELF-CHECK 1.2

Teacher check

SELF-CHECK 1.3

1. First-Angle Projection
2. Front View
3. Third-Angle Projection
4. Top View
5. Height
6. Width
7. Depth

SELF-CHECK 1.4

1. Orthographic projection
2. First quadrants
3. Second quadrant
4. Third quadrant
5. Fourth quadrant
6. First quadrant
7. Third quadrant
8. Horizontal plane
9. Frontal plane
10. Profile plane

SELF-CHECK 1.5

1. A - Pictorial drawing
2. D - Station point
3. B - Vanishing point
4. C - Man's-eye view
5. B - Cavalier oblique
6. Measure
7. Isometric
8. Non-Isometric lines

SELF-CHECK 1.6

1. B - Oblique drawing
2. B - Cavalier projection
3. B - 45 degrees
4. A - Cabinet projection
5. (At least three of the four given rules are the answers in any order.)
 - 5.1 Avoid positioning the longest side of the object to the picture plane.
 - 5.2 Place the circular and irregular surfaces of the object parallel to the picture plane.
 - 5.3 Dimensions on the receding axis of the cabinet drawings should be reduced to $\frac{1}{2}$ or $\frac{2}{3}$.
 - 5.4 If there is no given orthographic views, always proportion the details of the drawing to those of the actual object.

SELF-CHECK 1.8

1. Enlarge scale
2. Enlarge scale
3. Reduce scale
4. Full scale
5. Reduce scale
6. Enlarge scale
7. Reduce scale
8. Enlarge scale
9. Reduce scale
10. Enlarge scale

SELF-CHECK 1.9

1. D - Size dimension
2. A - Location dimension
3. C - Over-all dimension
4. A - Dimensioning
5. A - Aligned method
6. A - Detail dimension
7. D - Uni-directional method

SELF-CHECK 3.10

(Figure 3) Vee Block

Vee Block			
Part	Name	Quantity	Material
1	Body	1	TWS - 8 Gray Cast Iron
2	Yoke	1	ASTM 603 Forging Steel
3	Thumb screw	1	S.A.E. 1060 H.R.S.

ANSWER KEY - LESSON 4

LO1. Identify hazardous area

PRE-TEST

1. A
2. B
3. A
4. C
5. A
6. D
7. D
8. B
9. B
10. A

SELF CHECK # 1.1

1. Safety Standards
2. Moral
3. Legal
4. Occupational Safety and Health
5. Economic

SELF CHECK # 1.2

A. Before the start of drafting activity:

- Select the tools, materials and equipment which are needed in the assigned task.
- Properly set up the required tools and materials in a place which is convenient for you to move and execute your work.
- Clean the table and tools, see to it that these are free from the dust and other elements that would cause damage to your work.
- Wash your hand with clean water.

B. Activity proper:

- Perform the activity by following the standard operating procedure per job requirement.
- Properly manipulate all the tools and equipment that are used in the activity.
- In case of errors or mistakes along the way (for instance misprinting of lines, letters, and other forms of mistakes) use appropriate eraser.

C. After the activity:

- Submit your output to your teacher for checking
- Check all the tools and materials to ensure that nothing has lost.
- Return the tools and materials to the assigned tool keeper for safekeeping. Withdraw your borrower's card from the tool keeper and signed out that you have returned the borrowed tools and materials.

- Clean your work station before leaving.

SELF CHECK # 1.3

1. B
2. C
3. A
4. D
5. E

SELF CHECK # 1.4

1. C
2. A, B or D
3. E
4. A, B or D
5. A or D

SELF CHECK #1.5

1. SAFETY HAZARDS
2. BIOLOGICAL HAZARDS
3. CHEMICAL HAZARDS
4. ERGONOMIC HAZARDS
5. PHYSICAL HAZARDS

LO2. Use personal protective clothing

PRE-TEST

- A.
1. A
 2. B
 3. B
 4. D
 5. C
- B.
1. F
 2. T
 3. F
 4. T
 5. T

SELF CHECK # 2.1

1. *Appropriate clothing such as over-all / cover-all*
2. *Protective Headgear*
3. *Safety Glasses or Goggles*
4. *Gloves*
5. *Safety Boots or Shoes*

LIST OF MATERIALS / TOOLS/ EQUIPMENT/ CONSUMABLES FOR THIS MODULE

Drafting Materials

- Drawing Paper
- Drawing or Pen Ink
- Masking Tape
- Pencil-Ink Eraser
- Pencil Sharpener
- Pentel Pen
- Poster Color / Water Color / Coloring Pen or Pencils
- Tracing Paper
- CD/ DVD Tapes

Drafting Tools and Instruments

- Drawing Pencil (Hard, Medium, Soft)
- Erasing Shield
- Triangular Scales
- Compass
- Divider
- Drawing Templates
- French Curve
- Protractor
- Ruler
- Scales
- Tape or Tape Ruler
- Technical pens / Drawing Pen /Sign Pen
- T- Square
- Triangles

Equipment

- Computer Hardware
- Drawing Table /Drawing Board
- White Board
- Printer
- LCD Projector

Learning Materials

- Multimedia Materials (print, video, audio)
- Bibliography

Acknowledgement

This Learning Module was developed for the Exploratory Courses in Technology and Livelihood Education, Grades 7 and 8 of the K to 12 Curriculum with the assistance of the following persons:

This Learning Module on **MECHANICAL DRAWING NC I** was developed by the following personnel:

MODULE WRITERS

DANTE B. BERMAS

Pres. Sergio Osmena High School
Division of City Schools - Manila
National Capital Region (NCR)

MIRASOL F. DASIG

San Pedro Relocation Center N H.S.
San Pedro, Laguna
Region IV-A, Calabarzon

REVIEWERS

GIL P. CASUGA

Chief TESD Specialist

REYNALDO S. DANTES

Senior TESD Specialist

BERNADETTE S. AUDIJE

Senior TESD Specialist

MARIA A. ROQUE

Senior TESD Specialist

AIDA T. GALURA

VSA II, ACNTS

VICTORIO N. MEDRANO

Principal IV, SPRCNHS

PARALUMAN R. GIRON, Ed.D.

Chair, Sub-TWG on K to 10

BRENDA B. CORPUZ, Ph.D.

TA for K to 12 Curriculum

OFELIA O. FLOJO

Retired Assistant Chief, EED, RO IV-A

RODERICK AGUIRRE, Ph.D.

BEATRIZ A. ADRIANO

Principal IV, ERVHS

DOMINGA CAROLINA F. CHAVEZ

Principal II, MBHS

DOCUMENTORS / SECRETARIAT

PRISCILLA E. ONG

K to 12 Secretariat

FREDERICK G. DEL ROSARIO

Head Teacher III, BNAHS

EMMANUEL V. DIONISIO

Head Teacher III, AFGBMTS

LYMWEL P. LOPEZ

Teacher I, AFGBMTS

DANTE D. VERMON JR.

Teacher I, AFGBMTS

CHERLYN F. DE LUNA

Teacher I, AFGBMTS

LOUIE B. ANGELES

Teacher I, BNAHS

JOANNA LISA C. CARPIO

Teacher I, BNAHS

Dir. IMELDA B. TAGANAS

*Executive Director, Qualifications Standards Office
K to 12 Learning Area Team Convenor, TLE/TVE*